

2017 ABRASIVES AND WELDING CATALOG



SHARK INDUSTRIES LTD

2017 ABRASIVES AND WELDING CATALOG



SHARK ABRASIVES PRODUCT LINE

Introduction

Shark has been a supplier/manufacturer to the Automotive Aftermarket, Paint and Body and Industrial Marketplace for over 32 years. Your complete product satisfaction as well as a high quality customer service standard is what has created this success.

Our products have been designed with the professional mechanic, technician, welder or fabricator in mind. All our products are manufactured for professional or production use; from our abrasives to our wire/electrodes and equipment.

Our trilingual, 4 color packaging is attention getting and designed to stand out in any retail setting. The package descriptions are designed to offer the customer the optimum in purchasing accuracy.

Our small diameter cut-off wheels are manufactured in our Rockford, Minnesota facility and will give you an edge in performance and endurance. Our surface conditioning discs and flap discs are also made at our facility and are designed to compete with all major brands in the market today.

All our other products are sourced in the US as well as Europe, China, Taiwan, Turkey, Pakistan and Mexico to our exacting specifications. We insure that our quality levels meet our customers' most demanding requirements.

If you are dissatisfied for any reason we ask you to let us know by calling us at our toll-free number (800) 537-4275. You can also register a complaint or complement by e-mail to info@sharkind.com. We always welcome any suggestions on how we can improve our quality or our service level to you.

We look forward to servicing your needs for many years to come!

Shark is a registered trademark. Any use of the name without express written permission is prohibited. Any reproduction of this catalogue without the written permission of Shark is prohibited.

Shark is a manufacturer/repackager of its products. Any mention of any other manufacturer in this catalogue is only for reference of part number and is not intended to imply that Shark products are made by, or for the mentioned manufacturer; nor is it our intention to infringe on that company's trademark or patents.

No returns will be accepted without prior written approval from Shark. All stock returns must be accompanied by an off-setting order of greater value by 50% or more.



TABLE OF CONTENTS

Cut-Off Wheels	1-8	Accessories	115-130
Cut Off Wheels.....	3-8	Surface Protectant.....	117
Mandrels.....	8	Spark Suppressor.....	118
Grinding Wheels	9-16	Electrode Holders/Clamps.....	119
Grinding Wheels.....	11-14	Chipping Hammers.....	120
Cup Wheels.....	15	Soapstone.....	120
Flexible Grinding Wheels.....	16	Tip Cleaners.....	121
Backing Pads/Adaptors	17-22	Oxy-Acetylene Lighters and Flints.....	121
Backing Pads.....	19-21	Clamps.....	122
Adaptors.....	22	Magnets.....	123
Mandrels.....	22	Receptacles.....	124
Surface Prep/Grinding	23-52	Cable Lugs.....	125
Surface Prep Discs.....	28-32	Tank Adapters.....	125
Surface Prep Kits.....	33	Cylinder Wrenches.....	126
Strip Brite and Star-Brite Discs.....	34-35	Hose Accessories.....	127
Mini Grinding Discs.....	35-38	Oxy-Acetylene Gauges.....	128
Grinding Discs.....	39-42	Regulators.....	129
Buffing Bonnets.....	42	Safety Equipment	131-146
Sanding Sheets and Rolls.....	43-46	Welding Shields.....	133
Abrasive Assortment Kit.....	47-48	Headgear.....	134
Unitized Wheels.....	49-50	Eye Protection.....	135-137
Zirconia Mini Belts.....	51	Hearing Protection.....	138
Flap Discs	53-72	Masks.....	138-139
Zirconia Plastic-Backed Flap Discs.....	56	Welding Gloves.....	140-141
Ceramic.....	57	Welding Apparel.....	142-144
Aluminum Oxide.....	58-59	Welding Screens and Blankets.....	145
Zirconia.....	60-69	Cutting Kits	147-150
Mini Flap Discs.....	69	Medium Duty.....	149
Flap Wheels.....	70-71	Heavy Duty.....	150
Mounted Points	73-78	Plumber's Kit.....	150
Mounted Points.....	77	Tips & Nozzles	151-158
Mounted Point Kits.....	78	Cutting/Welding Nozzles.....	153-157
Bench Seat Wheels	79-82	Contact Tips.....	158
Bench Seat Grinding Accessories.....	81	Carbide Burs	159-168
Bench Seat Grinding Wheels.....	82	Carbide Burs.....	161-164
Welders-Helmets	83-104	Extended Carbide Burs.....	165
Welders.....	85-90	General Purpose Files.....	166
Spool Gun.....	91	Rotary Files.....	166-167
Plastic Welders.....	92-93	Wood Rasps.....	167
Welding Carts.....	94-95	Wire Brushes	169-178
Welding Helmets.....	96-101	Tube Brushes.....	171
Welding Lenses.....	102-103	Wire Brushes.....	171-173
Rod & Wire	105-114	Acid Brushes.....	173
Electrodes.....	107-111	Circular and Cup Wire brushes.....	174
Mig Wire.....	112	End Brushes.....	174-175
Solder.....	113-114	Wire Wheels.....	175-176
		Crimped Wire/Knotted Cup Brushes.....	176
		Wire Wheel Brushes.....	177
		Arbor Adaptors.....	178
		Welding Displays	179-180
		Paint and Body	181-188
		Auto Body Tools.....	183-184
		Pistol Vac.....	185
		Blow Guns and Accessories.....	185-186
		Blending Hammer.....	186
		Dolly Sets.....	187
		Blasting Media.....	188
		Crossover	189-192
		Index	193-197



SHARK INDUSTRIES

Cut-Off Wheels

- ▶ Aluminum Oxide/General Purpose
- ▶ Diamond Edge
- ▶ Silicon Carbide
- ▶ Zirconia
- ▶ Mandrels





NEW! DIAMOND EDGE CUT-OFF WHEELS

Use on all your current air tools and power tools at the same RPM's.

- 30 Times longer life than traditional abrasive cut-off wheels
- No need to continually change out wheels for different applications
- No odor and less dust
- Less sparking as only the metal is sparking and not the wheels
- One wheel meets all your different material needs

EXTENDED LIFE

The Shark Real-Cut diamond edge wheels are made of steel, using a high tech diamond technology for dramatic life extension in metal cutting applications. This decreases downtime, improves productivity, and lowers the cost of each cut in comparison to abrasive wheels.

APPLICATIONS

Designed for use on steel, sheet metal, stainless steel, rebar, cast iron, aluminum and all non-ferrous metals. When cutting aluminum use a form of lubricant for best results.



Part#	Diameter	Thickness	Arbor	RPM
13090	3"	.050	3/8"	25,000
13091	4"	.050	5/8"	15,300
13092	4.5"	.050	7/8"	13,300

CUT-OFF WHEELS

Fast cutting abrasive reinforced cut-off wheels are offered in a variety of formulas for different applications. The fiberglass reinforcement provides greater tensile strength as well as increased safety. All 3" and 4" wheels are American Made.

CUT-OFF WHEEL SHAPES

TYPE 1

Type 1 cut-off wheels are designed for cut-off applications that have easy access.



TYPE 27

Type 27 cut-off wheels are designed for use on angle grinders; incorporating the center depression which allows for flush grinding.



HOW TO CHOOSE THE RIGHT PRODUCT FOR YOUR APPLICATION

ALUMINUM OXIDE RESIN BONDED

Aluminum oxide bonded with resins, fiberglass reinforced for any steel cutting application.

ALUMINUM/SILICON CARBIDE

For use when cutting aluminum.

MASONRY/SILICON CARBIDE

Specially formulated for concrete cutting applications. Designed to reduce loading of the wheels.

STAINLESS STEEL/ZIRCONIA

For all stainless steel applications and harder metals. Offers extended life on regular steel.



CUT-OFF WHEELS



TYPE 1

Type 1 cut-off wheels are designed for all cut-off applications involving steel.

All wheels are double fiberglass reinforced, and are not designed for use on fiberglass or aluminum.

ALUMINUM OXIDE

Item#	Old#	Size	Thickness	Arbor	Grit	RPM	Grain	Pk. Qty	MP
19		2"	1/32"	3/8"	54	30,000	Aluminum Oxide	10	5
20		2"	1/16"	1/4"	54	30,558	Aluminum Oxide	10	5
21		2"	1/16"	3/8"	54	30,558	Aluminum Oxide	10	5
22		2"	1/8"	1/4"	54	45,000	Aluminum Oxide	10	5
23		2"	1/8"	3/8"	54	45,000	Aluminum Oxide	10	5
24-10		3"	1/16"	3/8"	46	25,000	Aluminum Oxide	10	20
24-20		3"	1/16"	3/8"	46	25,000	Aluminum Oxide	20	25
24-50		3"	1/16"	3/8"	46	25,000	Aluminum Oxide	50	10
24-100		3"	1/16"	3/8"	46	25,000	Aluminum Oxide	100	10
25-5		3"	1/16"	3/8"	54	25,000	Aluminum Oxide	5	50
25-6		3"	1/16"	3/8"	54	25,000	Aluminum Oxide	6	50
12704	25-10	3"	1/16"	3/8"	54	25,000	Aluminum Oxide	10	20
25-20		3"	1/16"	3/8"	54	25,000	Aluminum Oxide	20	20
25-25		3"	1/16"	3/8"	54	25,000	Aluminum Oxide	25	20
12705	25-50	3"	1/16"	3/8"	54	25,000	Aluminum Oxide	50	10
13215	25-100	3"	1/16"	3/8"	54	25,000	Aluminum Oxide	100	10
26-5		3"	1/32"	3/8"	54	25,000	Aluminum Oxide	5	50
26-6		3"	1/32"	3/8"	54	25,000	Aluminum Oxide	6	50
12700	26-10	3"	1/32"	3/8"	54	25,000	Aluminum Oxide	10	20
26-20		3"	1/32"	3/8"	54	25,000	Aluminum Oxide	20	25
26-25		3"	1/32"	3/8"	54	25,000	Aluminum Oxide	25	20
12701	26-50	3"	1/32"	3/8"	54	25,000	Aluminum Oxide	50	10
13216	26-100	3"	1/32"	3/8"	54	25,000	Aluminum Oxide	100	10
12702	27-10	3"	1/16"	1/4"	54	25,000	Aluminum Oxide	10	20
27-25		3"	1/16"	1/4"	54	25,000	Aluminum Oxide	25	20
12703		3"	1/16"	1/4"	54	25,000	Aluminum Oxide	50	10
27-100		3"	1/16"	1/4"	54	25,000	Aluminum Oxide	100	10
12706	28-5	3"	1/8"	1/4"	46	25,000	Aluminum Oxide	5	10
12707	28-50	3"	1/8"	1/4"	46	25,000	Aluminum Oxide	50	4
12708	29-5	3"	1/8"	3/8"	46	25,000	Aluminum Oxide	5	10
29-10		3"	1/8"	3/8"	46	25,000	Aluminum Oxide	10	20
12709	29-50	3"	1/8"	3/8"	46	25,000	Aluminum Oxide	50	4
30-10		3"	1/32"	1/4"	54	25,000	Aluminum Oxide	10	20
30-100		3"	1/32"	1/4"	54	25,000	Aluminum Oxide	100	10
37-10		3"	3/32"	3/8"	54	25,000	Aluminum Oxide	10	20
37-100		3"	3/32"	3/8"	54	25,000	Aluminum Oxide	100	5
38-5		3"	3/16"	3/8"	54	25,000	Aluminum Oxide	5	20
38-50		3"	3/16"	3/8"	54	25,000	Aluminum Oxide	50	4



CUT-OFF WHEELS



TYPE 1

Type 1 cut-off wheels are designed for all cut-off applications involving steel.

All wheels are double fiberglass reinforced. Not designed for use on fiberglass or aluminum.

Item#	Old#	Size	Thickness	Arbor	Grit	RPM	Grain	Pkg. Qty.	MP
41		4"	3/32"	5/8"	46	15,300	Aluminum Oxide	10	10
41-100		4"	3/32"	5/8"	46	15,300	Aluminum Oxide	100	5
12710	42	4"	1/32"	3/8"	60	21,000	Aluminum Oxide	10	10
12711		4"	1/32"	3/8"	60	21,000	Aluminum Oxide	50	4
42-100		4"	1/32"	3/8"	60	21,000	Aluminum Oxide	100	5
43		4"	1/32"	5/8"	60	21,000	Aluminum Oxide	10	10
43-100		4"	1/32"	5/8"	60	21,000	Aluminum Oxide	100	5
12718	44	4"	1/16"	1/4"	54	21,000	Aluminum Oxide	10	10
12719		4"	1/16"	1/4"	54	21,000	Aluminum Oxide	50	4
44-100		4"	1/16"	1/4"	54	21,000	Aluminum Oxide	100	5
12712	45	4"	1/16"	3/8"	54	21,000	Aluminum Oxide	10	10
12713		4"	1/16"	3/8"	54	21,000	Aluminum Oxide	50	4
45-100		4"	1/16"	3/8"	54	21,000	Aluminum Oxide	100	5
12716	46	4"	1/16"	5/8"	54	15,300	Aluminum Oxide	10	10
12717		4"	1/16"	5/8"	54	15,300	Aluminum Oxide	50	4
46-100		4"	1/16"	5/8"	54	15,300	Aluminum Oxide	100	5
12714	47	4"	1/8"	3/8"	46	15,300	Aluminum Oxide	10	10
12715		4"	1/8"	3/8"	46	15,300	Aluminum Oxide	50	4
47-100		4"	1/8"	3/8"	46	15,300	Aluminum Oxide	100	5
48		4"	1/8"	5/8"	46	15,300	Aluminum Oxide	10	10
48-100		4"	1/8"	5/8"	46	15,300	Aluminum Oxide	100	5
49		4"	1/8"	7/8"	46	15,300	Aluminum Oxide	10	10
49-100		4"	1/8"	7/8"	46	15,300	Aluminum Oxide	100	5
50		4"	1/16"	7/8"	46	15,300	Aluminum Oxide	10	10
50-100		4"	1/16"	7/8"	46	15,300	Aluminum Oxide	100	5
12722	454	4 1/2"	3/32"	7/8"	46	17,500	Aluminum Oxide	10	10
12723		4 1/2"	3/32"	7/8"	46	17,500	Aluminum Oxide	25	10
13067	455	4 1/2"	1/16"	7/8"	60	17,500	Aluminum Oxide	10	10
13068	456	4 1/2"	.045"	7/8"	46	17,500	Aluminum Oxide	10	10
13152		5"	.045"	7/8"	46	10,200	Aluminum Oxide	1	20
13153		5"	.045"	7/8"	46	10,200	Aluminum Oxide	5	20
13154		6"	.045"	7/8"	46	10,200	Aluminum Oxide	1	20
13155		6"	.045"	7/8"	46	10,200	Aluminum Oxide	5	20
13055		7"	.045"	7/8"	60	8,600	Aluminum Oxide	5	40
13082		7"	.045"	5/8"	46	8,500	Aluminum Oxide	5	40
13057		8"	.045"	7/8"	60	7,600	Aluminum Oxide	5	40

CUT-OFF WHEELS



SURE-LIFE CUT-OFF WHEELS

Item#	Old#	Size	Thickness	Arbor	Grit	RPM	Type	Shape	Pk. Qty	MP
12757	25SL	3"	1/16"	3/8"	36	25,000	Zirconia	Type 1	6	10
25SL-10		3"	1/16"	3/8"	36	25,000	Zirconia	Type 1	10	10
13217		3"	1/16"	3/8"	36	25,000	Zirconia	Type 1	50	4
12758	26SL	3"	1/32"	3/8"	60	25,000	Zirconia	Type 1	6	10
26SL-10		3"	1/32"	3/8"	60	25,000	Zirconia	Type 1	10	10
13218		3"	1/32"	3/8"	60	25,000	Zirconia	Type 1	50	4
29SL		3"	1/8"	3/8"	46	25,000	Zirconia	Type 1	6	10
37SL		3"	3/32"	3/8"	54	25,000	Zirconia	Type 1	6	10
38SL		3"	3/16"	3/8"	54	25,000	Zirconia	Type 1	6	10

FOR ALUMINUM CUTTING

13178		3"	1/16"	3/8"	54	25,000	Silicon Carbide		5	10
13179		3"	1/4"	3/8"	54	25,000	Silicon Carbide		5	10

CUT-OFF WHEELS WITH MANDRELS

We offer two types of wheels that come packed with our standard mandrel. Attractive clamshell packaging allows for easy storage of wheels not in use.

Item#	Old#	Size	Thickness	Arbor	Grit	RPM	Type	Shape	Pk. Qty	MP
12730	25-6M	3"	1/16"	3/8"	54	25,000	Aluminum Oxide	Type 1	6	20
Includes: 6 Cut-off Wheels and 1 Mandrel with a 3/8" Shoulder Screw										
128-83	26-6M	3"	1/32"	3/8"	54	25,000	Aluminum Oxide	Type 1	6	20
Includes: 6 Cut-off Wheels and 1 Mandrel with a 3/8" Shoulder Screw										
25SL-M		3"	1/16"	3/8"	36	25,000	Zirconia	Type 1	6	20
Includes: 6 Cut-off Wheels and 1 Mandrel with a 3/8" Shoulder Screw										
26SL-M		3"	1/32"	3/8"	60	25,000	Zirconia	Type 1	6	20
Includes: 6 Cut-off Wheels and 1 Mandrel with a 3/8" Shoulder Screw										



STAINLESS STEEL CUT-OFF WHEELS

Item#	Size	Thickness	Arbor	Grit	RPM	Type	Shape	Pk. Qty	MP
13021	4"	.045"	5/8"	60	15,300	Stainless Steel	Type 1	10	10
13022	4"	.045"	5/8"	60	15,300	Stainless Steel	Type 1	25	10
13023	4 1/2"	.045"	7/8"	60	13,300	Stainless Steel	Type 1	10	10
13024	4 1/2"	.045"	7/8"	60	13,300	Stainless Steel	Type 1	25	10
13028	5"	.045"	7/8"	60	12,250	Stainless Steel	Type 1	5	10
13029	5"	.045"	7/8"	60	12,250	Stainless Steel	Type 1	25	10
13030	6"	.045"	7/8"	60	12,700	Stainless Steel	Type 1	5	10
13031	6"	.045"	7/8"	60	12,700	Stainless Steel	Type 1	25	10
13032	7"	.045"	7/8"	60	12,700	Stainless Steel	Type 1	5	10
13033	7"	.045"	7/8"	60	12,700	Stainless Steel	Type 1	25	10



CUT-OFF WHEELS



Type 27 Depressed Center



Type 1 Stainless Steel



Type 1 Diamond Arbor



Type 1 Masonry

TYPE 27 STAINLESS STEEL/ZIRCONIA CUT-OFF WHEELS

Item#	Size	Thickness	Arbor	Grit	RPM	Shape	Grain	Pk. Qty	MP
13034	4"	.045"	5/8"	60	15,300	Type 27	Zirconia	10	10
13035	4"	.045"	5/8"	60	15,300	Type 27	Zirconia	25	4
13036	4 1/2"	.045"	7/8"	60	13,300	Type 27	Zirconia	10	10
13037	4 1/2"	.045"	7/8"	60	13,300	Type 27	Zirconia	25	4
13038	5"	.045"	7/8"	60	12,250	Type 27	Zirconia	5	10
13039	5"	.045"	7/8"	60	12,250	Type 27	Zirconia	25	4
13040	6"	.045"	7/8"	60	12,700	Type 27	Zirconia	5	10
13041	6"	.045"	7/8"	60	12,700	Type 27	Zirconia	25	4
13042	7"	.045"	7/8"	60	12,700	Type 27	Zirconia	5	10
13043	7"	.045"	7/8"	60	12,700	Type 27	Zirconia	25	4

TYPE 27 DEPRESSED CENTER CUT-OFF WHEELS (for use with angle grinders)

SDP454	4 1/2"	.045"	7/8"	60	13,500	Type 27	Aluminum Oxide	1	N/A
SDP454-5	4 1/2"	.045"	7/8"	60	13,500	Type 27	Aluminum Oxide	5	10
SDP454-10	4 1/2"	.045"	7/8"	60	13,500	Type 27	Aluminum Oxide	10	20
SDP455-5	4 1/2"	1/16"	7/8"	60	13,500	Type 27	Aluminum Oxide	5	40

TYPE 1/TYPE 27 CUTTING/GRINDING WHEELS FOR ALUMINUM

13180	4 1/2"	3/32"	7/8"	36	8,700	Type 1	Silicon Carbide	5	10
13181	4 1/2"	1/8"	7/8"	36	8,700	Type 27	Silicon Carbide	5	10
13063	4 1/2"	1/4"	7/8"	36	8,700	Type 27	Silicon Carbide	5	10

TYPE 1 GRINDING WHEELS WITH DIAMOND SHAPED ARBORS

12724	7"	1/8"	5/8"	36	8,700	Type 1	Aluminum Oxide	1	10
13069	7"	1/8"	5/8"	36	8,700	Type 1	Aluminum Oxide	5	10
12725	7"	1/8"	5/8"	36	8,700	Type 1	Aluminum Oxide	25	4
13070	8"	1/8"	5/8"	36	7,600	Type 1	Aluminum Oxide	5	10

TYPE 1 MASONRY CUT-OFF WHEELS

12694	7"	1/8"	5/8"	24	8,700	Type 1	Silicon Carbide	1	10
12695	7"	1/8"	5/8"	24	8,700	Type 1	Silicon Carbide	10	10

*Diamond center

MANDRELS

Shark mandrels can be used to convert any die grinder into a cut-off tool using either 1/4" or 3/8" I.D. wheels. Be sure to wear proper eye protection/face mask, gloves and safety gear. Shark offers 7 different types of mandrels for any application.

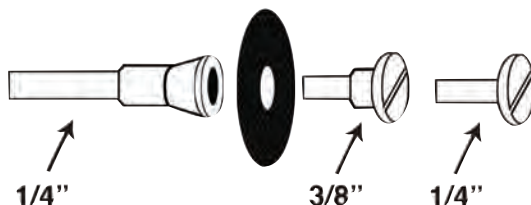

CUT-OFF WHEELS/MANDRELS

TYPE 1

12" & 14" CHOP SAW BLADES

Item#	Old#	Size	Thickness	Arbor	Grit	RPM	Reinforcement/Type	Grain	Pk. Qty	MP
124D		12"	3/32"	1"	36	5,000	Double	Aluminum Oxide	1	6
124-5		12"	3/32"	1"	36	5,000	Double	Aluminum Oxide	5	10
121-5		12"	1/8"	1"	36	5,100	Single	Aluminum Oxide	5	6
12726	122	12"	1/8"	1"	36	6,300	Double	Aluminum Oxide	1	5
12727		12"	1/8"	1"	36	6,300	Double	Aluminum Oxide	10	3
122-5		12"	1/8"	1"	36	6,300	Double	Aluminum Oxide	5	6
123-5		12"	7/64"	1"	36	5,100	Single	Aluminum Oxide	5	6
13058		12"	5/32"	20mm	24	6,400	Double/H.S. Gas/Elect. Saws	Zirconia	5	6
13059		12"	5/32"	1"	24	6,400	Double	Aluminum Oxide	5	6
12696	122M	12"	1/8"	1"	36	5,100	Double/Masonry	Silicon Carbide	1	5
12697		12"	1/8"	1"	36	5,100	Double/Masonry	Silicon Carbide	10	3
122M-5		12"	1/8"	1"	36	5,100	Double/Masonry	Silicon Carbide	5	6
141-5		14"	1/8"	1"	36	4,400	Single	Aluminum Oxide	5	6
13158	144D	14"	3/32"	1"	36	4,400	Double	Aluminum Oxide	1	5
13159	144-5	14"	3/32"	1"	36	4,400	Double	Aluminum Oxide	5	6
12728	142	14"	1/8"	1"	36	4,400	Double	Aluminum Oxide	1	5
12729		14"	1/8"	1"	36	4,400	Double	Aluminum Oxide	10	3
12663	142-5	14"	1/8"	1"	36	4,400	Double	Aluminum Oxide	5	6
143-5		14"	7/64"	1"	36	4,400	Double	Aluminum Oxide	5	6
13060		14"	5/32"	20mm	24	5,460	Triple/H.S. Gas/Elect. Saws	Aluminum Oxide	5	6
13061		14"	5/32"	1"	24	5,400	Triple/H.S. Gas/Elect. Saws	Aluminum Oxide	5	6
12698	142M	14"	1/8"	1"	24	4,400	Double/Masonry	Silicon Carbide	1	5
12699		14"	1/8"	1"	24	4,400	Double/Masonry	Silicon Carbide	10	3
142M-5		14"	1/8"	1"	24	4,400	Double/Masonry	Silicon Carbide	5	6
142MH-5		14"	1/8"	1"	24	4,400	Double/HD Masonry	Silicon Carbide	5	6

12782

Mandrel for 14607 Strip-Brite Disc (p. 34)



12431 (31)

Mandrel with 3/8" shoulder screw



12935 (32)

Mandrel with 1/4" & 3/8" shoulder screw



12433 (33)

Mandrel with 3/8" Extended Shoulder Screw. For use with wheels thicker than 3/8" with 3/8" arbor hole



12693 (34)

Mandrel with 1/2" adaptor



37L

Mandrel with 1/4" extended screw for wheels thicker than 3/8"



37S

Mandrel with only a 1/4" shoulder screw





SHARK INDUSTRIES

Grinding Wheels

- ▶ Type 1
- ▶ Type 27
- ▶ Type 28
- ▶ Type 11





GRINDING WHEELS

Shark offers various wheel styles for all your applications. Easy diagrams below for identifying the best wheel configuration for your project.

GRINDING WHEEL SHAPES

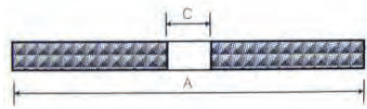

TYPE 1

An all around edge grinding wheel design; but not used for cutting.

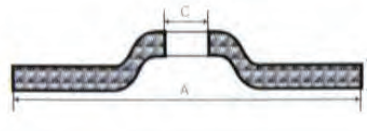

TYPE 27

Grinding wheels with depressed centers used for grinding on flat surfaces and edge cleaning.

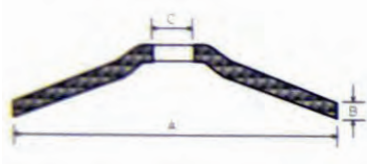

TYPE 28

This design offers great area coverage and improved user visibility for de-burring and other edge preparation work.

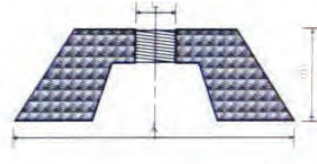

TYPE 11

Abrasive cup wheels offer even more area coverage than saucer shaped wheels. These are best for clearing material on large flat areas, also great for heavy welds.

HOW TO PICK THE RIGHT GRAIN TYPE



ALUMINUM OXIDE

This general purpose bond offers excellent stock removal. Recommended for use on regular steel, structural steel, metal and welds.



MASONRY

Silicon carbide grain for grinding masonry, concrete, stone, and non-ferrous metals.



ZIRCONIA FOR STAINLESS STEEL

High performance grinding excellent on ferrous metals, castings and stainless steel.

GRINDING WHEELS

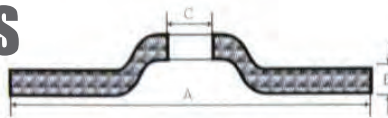

TYPE 27

Type 27 grinding wheels with depressed centers are used for grinding on flat surfaces and edge cleaning.

Item#	Old#	Size	Thickness	Arbor	Grit	RPM	Grain	Shape	Pk. Qty	MP
SDP220		2"	3/16"	3/8"	120	25,000	Aluminum Oxide	Type 27	5	20
SDP280		2"	3/16"	3/8"	80	25,000	Aluminum Oxide	Type 27	5	20
SDP260		2"	3/16"	3/8"	60	25,000	Aluminum Oxide	Type 27	5	20
SDP301		3"	1/8"	3/8"	36	20,000	Aluminum Oxide	Type 27	1	50
SDP401		4"	1/8"	5/8"	36	13,700	Aluminum Oxide	Type 27	1	50
12731	SDP401-4	4"	1/8"	5/8"	36	13,700	Aluminum Oxide	Type 27	4	12
SDP401-5		4"	1/8"	5/8"	36	13,700	Aluminum Oxide	Type 27	5	15
SDP401-25		4"	1/8"	5/8"	36	13,700	Aluminum Oxide	Type 27	25	8
SDP402		4"	1/4"	3/8"	24	13,700	Aluminum Oxide	Type 27	1	50
SDP402-3		4"	1/4"	3/8"	24	13,700	Aluminum Oxide	Type 27	3	10
SDP402-5		4"	1/4"	3/8"	24	13,700	Aluminum Oxide	Type 27	5	15
SDP402-25		4"	1/4"	3/8"	24	13,700	Aluminum Oxide	Type 27	25	4
SDP402-100		4"	1/4"	3/8"	24	13,700	Aluminum Oxide	Type 27	100	4
SDP404		4"	1/4"	5/8"	24	13,700	Aluminum Oxide	Type 27	1	50
12732	SDP404-3	4"	1/4"	5/8"	24	13,700	Aluminum Oxide	Type 27	3	10
SDP404-5		4"	1/4"	5/8"	24	13,700	Aluminum Oxide	Type 27	5	15
12733	SDP404-25	4"	1/4"	5/8"	24	13,700	Aluminum Oxide	Type 27	25	4
SDP404-100		4"	1/4"	5/8"	24	13,700	Aluminum Oxide	Type 27	100	4
SDP451		4 1/2"	1/8"	7/8"	36	11,900	Aluminum Oxide	Type 27	1	50
SDP451-3		4 1/2"	1/8"	7/8"	36	11,900	Aluminum Oxide	Type 27	3	10
SDP451-5		4 1/2"	1/8"	7/8"	36	11,900	Aluminum Oxide	Type 27	5	15
SDP451-25		4 1/2"	1/8"	7/8"	36	11,900	Aluminum Oxide	Type 27	25	4
SDP452		4 1/2"	1/4"	7/8"	24	11,900	Aluminum Oxide	Type 27	1	50
12734	SDP452-3	4 1/2"	1/4"	7/8"	24	11,900	Aluminum Oxide	Type 27	3	10
SDP452-5		4 1/2"	1/4"	7/8"	24	11,900	Aluminum Oxide	Type 27	5	15
12735	SDP452-25	4 1/2"	1/4"	7/8"	24	11,900	Aluminum Oxide	Type 27	25	4
SDP452-100		4 1/2"	1/4"	7/8"	24	11,900	Aluminum Oxide	Type 27	100	4
12750	SDP452H	4 1/2"	1/4"	5/8"-11	24	11,900	Aluminum Oxide	Type 27	1	20
12751		4 1/2"	1/4"	5/8"-11	24	11,900	Aluminum Oxide	Type 27	25	4
SDP501N		5"	1/8"	7/8"	24	11,900	Aluminum Oxide	Type 27	1	50
SDP502		5"	1/4"	5/8"-11	24	11,000	Aluminum Oxide	Type 27	1	50
SDP502-25		5"	1/4"	5/8"-11	24	11,000	Aluminum Oxide	Type 27	25	4
12736	SDP502N	5"	1/4"	7/8"	24	12,000	Aluminum Oxide	Type 27	1	50
12737		5"	1/4"	7/8"	24	11,000	Aluminum Oxide	Type 27	25	8
13156		6"	1/4"	7/8"	24	10,200	Aluminum Oxide	Type 27	1	25
13157		6"	1/4"	7/8"	24	10,200	Aluminum Oxide	Type 27	5	10
12752	SDP701	7"	1/8"	5/8"-11	24	8,500	Aluminum Oxide	Type 27	1	10
SDP701-10		7"	1/8"	5/8"-11	24	8,500	Aluminum Oxide	Type 27	10	5
SDP701N		7"	1/8"	7/8"	24	8,500	Aluminum Oxide	Type 27	1	20
12753	SDP702	7"	1/4"	5/8"-11	24	8,500	Aluminum Oxide	Type 27	1	10
12754	SDP702-10	7"	1/4"	5/8"-11	24	8,500	Aluminum Oxide	Type 27	10	2
12738	SDP702N	7"	1/4"	7/8"	24	8,500	Aluminum Oxide	Type 27	1	25
12741	SDP702N-10	7"	1/4"	7/8"	24	8,500	Aluminum Oxide	Type 27	10	10



GRINDING WHEELS TYPE 27



ALUMINUM OXIDE

Item#	Old#	Size	Thickness	Arbor	Grit	RPM	Shape	Pk. Qty	MP
12689	SDP901	9"	1/8"	5/8"-11	24	6,500	Type 27	1	10
12755	SDP902	9"	1/4"	5/8"-11	24	6,500	Type 27	1	10
12756	SDP902-10	9"	1/4"	5/8"-11	24	6,500	Type 27	10	2
12739	SDP902N	9"	1/4"	7/8"	24	6,500	Type 27	1	10
12740	SDP902N-10	9"	1/4"	7/8"	24	6,500	Type 27	10	5

ZIRCONIA DEPRESSED CENTER GRINDING WHEELS

12639	SDP452Z	4 1/2"	1/4"	7/8"	24	11,900	Type 27	1	25
12640	SDP452Z-25	4 1/2"	1/4"	7/8"	24	11,900	Type 27	25	8
12641	SDP452ZH	4 1/2"	1/4"	5/8"-11	24	11,900	Type 27	1	25
12642	SDP702NZ-5	7"	1/4"	7/8"	24	8,500	Type 27	5	20
12643	SDP702Z	7"	1/4"	5/8"-11	24	8,500	Type 27	1	20
12644	SDP702Z-10	7"	1/4"	5/8"-11	24	8,500	Type 27	10	2
12645	SDP902Z	9"	1/4"	5/8"-11	24	6,500	Type 27	1	20
12646	SDP902Z-10	9"	1/4"	5/8"-11	24	6,500	Type 27	10	2

MASONRY DEPRESSED CENTER WHEELS

12742	SDP404SC	4"	1/4"	5/8"	A24R	13,500	Type 27	1	25
12647	SDP404SC-5	4"	1/4"	5/8"	A24R	13,500	Type 27	5	10
12743	SDP404SC-25	4"	1/4"	5/8"	A24R	13,500	Type 27	25	8
12744	SDP452SC	4 1/2"	1/4"	7/8"	A24R	10,850	Type 27	1	25
12648	SDP452SC-5	4 1/2"	1/4"	7/8"	A24R	10,850	Type 27	5	10
12745	SDP452SC-25	4 1/2"	1/4"	7/8"	A24R	10,850	Type 27	25	8
12649	SDP502SC-25	5"	1/4"	7/8"	A24R	8,500	Type 27	25	8
12746		7"	1/4"	5/8"-11	A24R	6,600	Type 27	1	10
12747	SDP702SC-10	7"	1/4"	5/8"-11	A24R	6,600	Type 27	10	2
12748		9"	1/4"	5/8"-11	A24R	6,500	Type 27	1	10
12749	SDP902SC-10	9"	1/4"	5/8"-11	A24R	6,500	Type 27	10	2

PIPELINE CUTTING/GRINDING WHEELS

These Metal / Stainless Steel wheels are specially designed for light grinding on welds and cutting of root pass.

Item#	Old#	Size	Thickness	Arbor	Grit	RPM	Shape	Pk. Qty	MP
13049		4 1/2"	1/8"	7/8"	24	13,300	Type 27	10	5
13050		4 1/2"	1/8"	5/8"-11	24	13,300	Type 27	10	5
13051		6"	1/8"	7/8"	24	10,020	Type 27	5	5
13052		6"	1/8"	5/8"-11	24	10,020	Type 27	5	5
13053		7"	1/8"	7/8"	24	8,600	Type 27	5	5
13054		7"	1/8"	5/8"-11	24	8,600	Type 27	5	5

GRINDING WHEELS

KOOLIE HAT WHEELS

Item#	Old#	Size	Thickness	Arbor	Grit	RPM	Shape	Pk. Qty	MP
12759	SKP702	7"	1/4"	5/8"-11	24	8,500	Type 28	1	10
12760	SKP702-10	7"	1/4"	5/8"-11	24	8,500	Type 28	10	2
12761	SKP902	9"	1/4"	5/8"-11	24	6,500	Type 28	1	10
12762	SKP902-10	9"	1/4"	5/8"-11	24	6,500	Type 28	10	2



TYPE 28

This design offers great area coverage and improved user visibility for de-burring work and other edge preparation work.

GRINDING WHEELS FOR ALUMINUM

Item#	Size	Thickness	Arbor	Grit	RPM	Shape	Pk. Qty	MP
13063	4 1/2"	1/4"	7/8"	24	13,300	Type 27	5	10
13064	4 1/2"	1/4"	5/8"-11	24	13,300	Type 27	1	5
12763	7"	1/4"	7/8"	24	8,600	Type 27	5	10
12764	7"	1/4"	5/8"-11	24	8,600	Type 27	5	2
13072	7"	3/16"	7/8"	24	8,600	Type 1	5	10

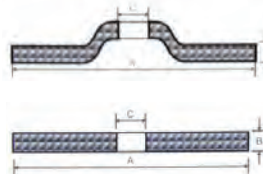

TYPE 27/TYP 1

Grinding wheels with depressed centers are used for grinding on flat surfaces and edge cleaning.





GRINDING WHEELS

CUP WHEEL



TYPE 11

A resinoid bonded, aluminum oxide cup wheel for use on portable grinders. For large weld grinding applications.

Abrasive cup wheels offer even more area coverage than saucer shaped wheels. These are best for clearing material on large flat areas requiring a very aggressive wheel.

Item#	Size	Thickness	Arbor	Grit	RPM	Grain	Shape	Pk. Qty
12690	4/3"	2"	5/8"-11	16-20	7,260	Aluminum Oxide	Type 11	1
12691	5/4"	2"	5/8"-11	16-20	6,500	Aluminum Oxide	Type 11	1
12692	6/5"	2"	5/8"-11	16-20	6,000	Aluminum Oxide	Type 11	1

FLYWHEEL GRINDING WHEEL

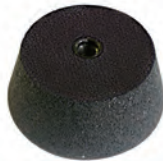

Silicon Carbide flywheel grinding wheel. For use on DCM Tech, Kwik-Way, Peterson, Tobin Arp and Winona Machines.

Item#	Size	Thickness	Arbor	Grit	RPM	Grain	Shape	Pk. Qty
56	4" / 3"	1 1/2"	1 1/4"	46	5,730	Silicon Carbide	Type 11	1
57	6" / 4/5"	2 5/8"	1 1/2"	36	4,775	Silicon Carbide	Type 11	1



FLEXIBLE GRINDING WHEELS



Conforming, double reinforced Aluminum Oxide grinding wheel that becomes more pliable when used, and flexes to follow contoured surfaces.

FLEXI-WHEELS

Item#	Old#	Size	Thickness	Arbor	Grit	RPM	Style	Shape	Pk. Qty	MP
12765	4036	4"	1/8"	5/8"	36	13,500	Flexible Grinding Wheel	Type 27	1	10
4036-10		4"	1/8"	5/8"	36	13,500	Flexible Grinding Wheel	Type 27	10	5
4046		4"	1/8"	5/8"	46	13,500	Flexible Grinding Wheel	Type 27	1	10
4046-10		4"	1/8"	5/8"	46	13,500	Flexible Grinding Wheel	Type 27	10	5
12766	4060	4"	1/8"	5/8"	60	13,500	Flexible Grinding Wheel	Type 27	1	10
4060-10		4"	1/8"	5/8"	60	13,500	Flexible Grinding Wheel	Type 27	10	5
12767		4 1/2"	1/8"	7/8"	36	13,300	Flexible Grinding Wheel	Type 27	1	10
4536-3		4 1/2"	1/8"	7/8"	36	13,300	Flexible Grinding Wheel	Type 27	3	5
4536-10		4 1/2"	1/8"	7/8"	36	13,300	Flexible Grinding Wheel	Type 27	10	5
4546-3		4 1/2"	1/8"	7/8"	46	13,300	Flexible Grinding Wheel	Type 27	3	5
4546-10		4 1/2"	1/8"	7/8"	46	13,300	Flexible Grinding Wheel	Type 27	10	5
12768		4 1/2"	1/8"	7/8"	60	13,300	Flexible Grinding Wheel	Type 27	1	10
4560-3		4 1/2"	1/8"	7/8"	60	13,300	Flexible Grinding Wheel	Type 27	3	5
4560-10		4 1/2"	1/8"	7/8"	60	13,300	Flexible Grinding Wheel	Type 27	10	5
12769	7036	7"	1/8"	7/8"	36	8,500	Flexible Grinding Wheel	Type 27	1	5
7036-10		7"	1/8"	7/8"	36	8,500	Flexible Grinding Wheel	Type 27	10	5
7036H-10		7"	1/8"	5/8"-11	36	8,500	Flexible Grinding Wheel	Type 27	10	2
7046		7"	1/8"	7/8"	46	8,500	Flexible Grinding Wheel	Type 27	1	5
7046-10		7"	1/8"	7/8"	46	8,500	Flexible Grinding Wheel	Type 27	10	5
7046H-10		7"	1/8"	5/8"-11	46	8,500	Flexible Grinding Wheel	Type 27	10	2
12770	7060	7"	1/8"	7/8"	60	8,500	Flexible Grinding Wheel	Type 27	1	5
7060-10		7"	1/8"	7/8"	60	8,500	Flexible Grinding Wheel	Type 27	10	2
7060H-10		7"	1/8"	5/8"-11	60	8,500	Flexible Grinding Wheel	Type 27	10	2
7080		7"	1/8"	7/8"	80	8,500	Flexible Grinding Wheel	Type 27	1	5
7080-10		7"	1/8"	7/8"	80	8,500	Flexible Grinding Wheel	Type 27	10	2
7080H-10		7"	1/8"	5/8"-11	80	8,500	Flexible Grinding Wheel	Type 27	10	2





Backing Pads/Adaptors

- ▶ Thermostat Gasket Removers
- ▶ Vented Backing Pads
- ▶ Velcro Backing Pads
- ▶ Twist-to-Lock Backing Pads
- ▶ Mandrels
- ▶ Adaptors





NEW! THERMOSTAT GASKET REMOVER

Cleans all hard to reach gasket surfaces. Also works for cleaning up oil pans, water pumps, and other inaccessible applications. Replaceable abrasive pad works in seconds. The tool is equipped with a floating guide shaft so the user can easily steer the abrasive pad around the gasket surface.



Item#	Size	Type	Shank Diameter	Pk. Qty.	MP
13084	2" x 7 1/2"	Type "R" Holder with Extended Shaft	1/4" Guide Shaft	1	5
13085	7 1/2"	Extended Guide Shaft	1/4" Guide Shaft	1	5
13012	2"	Type "R" Twist-to-Lock Holder (sold separately)	1/4" Mandrel	1	20

BACKING PADS/ADAPTORS

Shark Industries has several types of backing pads and adaptors to secure the abrasives for multiple jobs. Some pads can even make your tool more versatile by allowing you to use other abrasives on it.



TWIST-TO-LOCK VENTED BACKING PAD

2", 3" and 4" Twist-to-lock Type R vented backing pads.
Tool: Angle or straight grinders.
Use with: Mini grinding discs, mini flap discs and surface prep-discs.



VELCRO MINI BACKING PAD

For use on Snap-on, Mac, Matco, or other mini Sanders.
Tool: Any pistol style 3" sander using female threads.
Use with: 3" Velcro sanding discs.



TWIST-TO-LOCK BACKING PAD

2", 3" and 4" Twist-to-lock Type R quick change backing pad.
Tool: Right Angle Grinders and Die Grinders.
Use with: Surface prep, mini grinding, strip-it and mini flap discs.



RUBBER BACKING PAD

Quality backing pad to fit all 4-7" grinders. Turbo pad with vents affords users a cooler disc and longer life.
Tool: Angle grinders.
Use with: Resin fiber discs.



VELCRO BACKING PAD

2", 3" and 4" Velcro backing pad.
Tool: Angle or straight grinders.
Use with: Mini grinding discs, mini flap discs and surface prep-discs with velcro backing.



TYPE R MINI GRINDER BACKING PAD

Add instant versatility to your 2" grinder. Twist-to-lock receptacle.
Tool: 2" Right Angle Mini Grinders; CP7500, Sunex SXC606, Mac Tools AG200, Matco and Snap-On.
Use with: Surface prep, mini grinding, strip-it and mini flap discs.

BACKING PADS/ADAPTORS



2", 3" and 4" vented Twist-to-lock type backing pads.
Tool: Right Angle Grinders and Die Grinders.
Use with: Surface prep, mini grinding, strip-it and mini flap discs.
Made in USA.

2" - 4" VENTED BACKING PAD (TYPE R)

Item#	Size	Type	Style	Pk. Qty.	MP
44320	2"	Turbo	Twist-to-lock Holder w/ 1/4" Mandrel	1	10
44321	3"	Turbo	Twist-to-lock Holder w/ 1/4" Mandrel	1	10
44322	4"	Turbo	Twist-to-lock Holder w/ 1/4" Mandrel	1	10



2", 3" and 4" Twist-to-lock backing pad.
 Compatible with all twist-to-lock brands of discs, this high quality holder has a rigid rubber pad and twist-to-lock attachment.
Tool: Right Angle Grinders and Die Grinders.
Use with: Surface prep, mini grinding, strip-it and mini flap discs.

2" - 4" TWIST-TO-LOCK BACKING PAD (TYPE R)

Item#	Old#	Size	Type	Style	Pk. Qty.	MP
13012	323T	2"	Twist-to-Lock	Twist-to-lock Backing Pad w/Mandrel	1	20
323T-50		2"	Twist-to-Lock	Twist-to-lock Backing Pad w/Mandrel	50	5
13013	333T	3"	Twist-to-Lock	Twist-to-lock Backing Pad w/Mandrel	1	20
333T-50		3"	Twist-to-Lock	Twist-to-lock Backing Pad w/Mandrel	50	5
13014	343T	4"	Twist-to-Lock	Twist-to-lock Backing Pad w/Mandrel	1	10
343T-50		4"	Twist-to-Lock	Twist-to-lock Backing Pad w/Mandrel	50	2



2", 3" and 4" Velcro backing pad.
Tool: Right Angle Grinders and Die Grinders.
Use with: Velcro backed sanding discs
Made in USA.

2" - 4" VELCRO BACKING PAD

Item#	Size	Type	Style	Pk. Qty.	MP
323	2"	Velcro	Holder with 1/4" Shank	1	5
333	3"	Velcro	Holder with 1/4" Shank	1	5
343	4"	Velcro	Holder with 1/4" Shank	1	5



Adds instant versatility to your 2" grinder.
Tool: 2" Right Angle Mini Grinders; CP7500, Sunex SXC606, Mac Tools AG200, Matco and Snap-On.
Use with: Surface prep, mini grinding, strip-it and mini flap discs.

2" - 3" MINI GRINDER BACKING PADS (TYPE R)

Item#	Size	Type	Style	Pk. Qty.	MP
13025	2"	3/8"-24 Thread	Twist-to-lock	1	20
13026	3"	3/8"-24 Female Thread	Twist-to-lock	1	20



BACKING PADS/ADAPTORS



For use on Snap-on, Mac, and Matco Mini Sanders.

Tool: Any pistol style 3" sander using female threads.

Use with: 3" Velcro sanding discs.

VELCRO MINI BACKING PAD

Item#	Size	Type	Style	Pk. Qty.
333S	3"	Velcro	1/4"-20 Female Thread Screw Backing Pad	1
333SP	3"	Velcro	5/16"-24 Female Thread Screw Backing Pad	1



Quality backing pad to fit all 4-7" angle grinders. Turbo pad with vents affords users a cooler disc thereby offering you longer life.

Tool: 4"-7" Angle Grinder

Use with: 4"-7" Resin Fiber Discs

RUBBER BACKING PAD

Item#	Size	Type	Style	Pk. Qty.
13201	4"	Rubber	M10-1.25 Backing Pad for Sander	1
13202	4"	Rubber	M10-1.50 Backing Pad for Sander	1
13203	4"	Rubber	Backing Pad without nut for Sander	1
13204	4.5"	Rubber	5/8"-11NC Backing Pad for Sander	1
13205	5"	Rubber	5/8"-11NC Backing Pad for Sander	1
13206	7"	Rubber	5/8"-11NC Backing Pad for Sander	1
13207	7"	Rubber	Backing Pad without nut for Sander	1



SPINDLE NUT FOR RUBBER BACKING PAD

Nut used to attach the pad to the tool, which are frequently lost. One per pack.

Part#	Description
13209	M10-1.25
13210	M10-1.50
13211	Nut for 5/8"-11 Hub



SPINDLE NUT WRENCH

Adjustable wrench used for installation and removal of spindle nuts with holes. One per pack.

Part#	Description
13212	Spindle Nut Wrench

BACKING PADS/ADAPTORS

DEPRESSED CENTER WHEEL ADAPTOR

Adaptor readily adapts any depressed center wheel with 7/8" hole to a 5/8"-11NC spindle for use with a standard right angle grinder. Wrench included.

Part#	Description
13213	Kit Includes: Wrench, Adaptor, 2 washers and nut.



MANDRELS

Shark mandrels can be used to convert any die grinder into a cut-off tool using wheels with either 1/4" or 3/8" I.D. Be sure to wear proper eye protection/face mask, gloves and safety gear.

Shark offers 7 different types of Mandrels for any application.

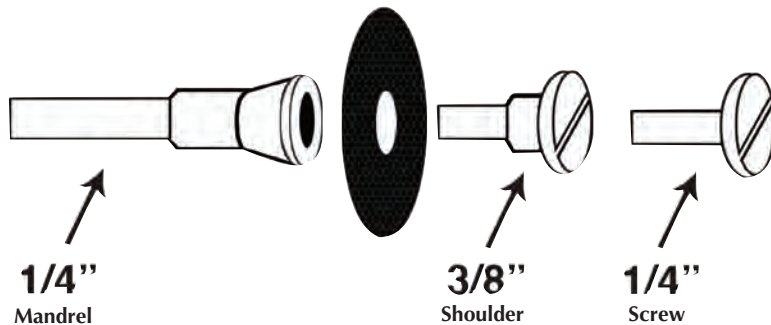

12782

Mandrel for 14607 Strip-Brite Disc (p. 34)



12431 (31)

Mandrel with 3/8" shoulder screw



12935

Mandrel with 1/4" & 3/8" shoulder screw



12433

Mandrel with 3/8" Extended Shoulder Screw. For use with wheels thicker than 3/8" with 3/8" arbor hole



12693 (34)

Mandrel with 1/2" adaptor



37L

Mandrel with 1/4" extended screw for wheels thicker than 3/8"



37S

Mandrel with only a 1/4" shoulder screw





shark

MADE IN USA

SHARK INDUSTRIES

Surface Prep/Grinding

- ▶ Surface Conditioning Discs
- ▶ Star-Brite Polishing Discs
- ▶ Star-Brite Sanding Discs
- ▶ Strip-Brite Pads
- ▶ Cloth Backed Mini Grinding Discs
- ▶ Resin Backed Mini Grinding Discs
- ▶ Ceramic Mini Grinding Discs
- ▶ Green Zirconia Mini Grinding Discs
- ▶ Resin Fiber Grinding Discs
- ▶ Sheepskin Pads
- ▶ Wool Felt Pads
- ▶ Emery Cloth Sheets
- ▶ Silicon Carbide Wet and Dry Paper
- ▶ Super Gold 5" and 6" Discs
- ▶ Sandscreen Sheets
- ▶ Abrasive File Sheets
- ▶ Zirconia Mini-Grinding Belts



GRINDING DISCS

Surface preparation is the most important step in creating a quality bond. Surfaces are often covered with dust, dirt, grease, oil, oxide films, rust inhibitors, and in the case of plastics, mold release agents. All these contaminants, even at a microscopic level, interfere with the adhesive doing its job properly. In fact, poor surface preparation is the number one cause of bond failure.

GRAIN OPTIONS

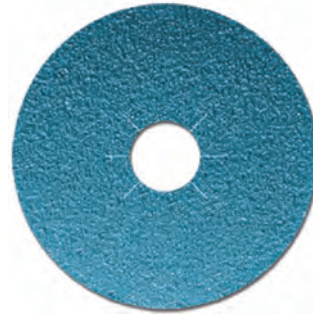

ALUMINUM OXIDE

Properties:

- Aggressive cutting
- High cut performance
- Good productivity

Grinding and finishing of welding parts and all kinds of steel. Not optimum on stainless steel.

ZIRCONIA

Properties:

- Fast cutting performance, while long wearing
- Increased productivity
- Cool cutting as well as long life

Grinding heavy metals and stainless steel parts.

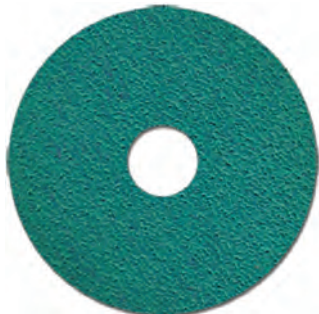

GREEN ZIRCONIA

Properties:

- High cut performance
- Increased productivity
- Cool cutting
- Extremely long life

Grinding of high alloy/stainless steel parts and edging. Use where heat absorbance is critical.

CERAMIC

Properties:

- Excellent grinding performance
- Cool & aggressive cutting
- Self sharpening for outstanding life

Grinding and finishing of stainless steel, high alloy steels, chrome, nickel, and titanium.

SURFACE PREP/GRINDING

SURFACE CONDITIONING DISCS

Specifications:

For general grinding, rust removal, clean-up and paint removal. Offering 6 different grits.

Tool: Right angle grinders or die grinders.



ALUMINUM OXIDE MINI GRINDING DISCS

Specifications:

For general purpose grinding. Available in grits from 24-120.

Tool: Right angle grinders or die grinders.



STAR-BRITE POLISHING DISCS

Best For: Polishing and finishing after grinding. 2 grits options offered.

Tool: 4 1/2" angle grinders.

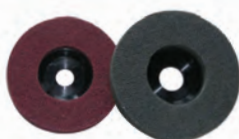

GREEN ZIRCONIA MINI GRINDING DISCS

Specifications:

For grinding on steel or stainless steel. Long life grain from 24-120 grit.

Tool: Right angle grinders or die grinders.



STAR-BRITE SANDING PADS

Best For: For hard sanding and general clean-up. 3 grit options offered.



CERAMIC MINI GRINDING DISCS

Specifications:

For very long life and heavy duty grinding jobs. Available in grits from 24-120.

Tool: Right angle grinders or die grinders.



TYPE 27 STRIP-BRITE DISCS

Specifications:

Available in 3 grades, 4 1/2" & 7".

Best For: Use in paint and rust removal. Will not damage the metal while grinding. Low sparking product.

Tool: 4 1/2" - 7" angle grinders.



RESIN FIBRE SANDING DISCS

Specifications:

Aluminum Oxide and Zirconia grain.

Tool: 4" - 9" angle grinders.



STRIP-BRITE PADS

Specifications:

Available in 3 grades, 2" & 3" with a twist-to-lock backing.

Tool: Right angle grinders or die grinders.

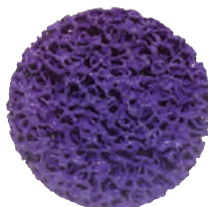

SHEEPSKIN PAD

Specifications:

All natural sheepskin pad for use with Velcro backing pads.

Best For:

Eliminating defects while removing as little paint as possible. Can remove swirl marks, oxidation, scratches, bird etchings and acid rain.

Tool: Right angle grinders or die grinders.



CLOTH BACKED GRINDING DISCS

Specifications:

Aluminum Oxide or Zirconia in 2"-3", 24-120 grit.

Tool: Right angle grinders or die grinders.

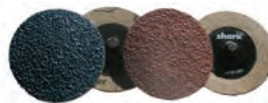

WOOL FELT PAD

Specifications:

High quality wool felt will not fray.

Best For: Polishing metals or plastics.

Tool: Right angle grinders or die grinders.





SURFACE PREP/GRINDING



GENERAL PURPOSE DRY SANDING PAPER

Specifications:

A great general purpose sheet for dry sanding applications on plastic, metal or fiberglass.

Best For: Use for feather-edging, sanding scratches, finishing plastic fillers and paint removal.

Tool: Cut to fit power sander, block or hand sanding.

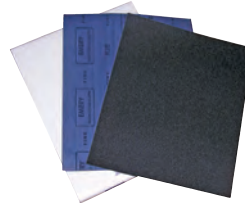

EMERY CLOTH SHEETS

Specifications: Emery Grain with cloth backing.

Best For: Sanding and polishing

Tool: Use by hand.



SILICON CARBIDE WET/DRY PAPER

Specifications:

Silicon carbide grit designed to prevent loading when sanding. A great purpose sheet for dry sanding applications on plastic, metal or fiberglass automotive surfaces.

Best For: Use for feather-edging, sanding scratches, finishing plastic fillers and paint removal.

Tool: Cut to fit power sander, block or hand sanding.



SUPER GOLD DISCS

Specifications:

Aluminum Oxide on "C" weight backing.

Best For: Auto body or manufacturing sanding needs.

Tool: Orbital Sander.



SANDSCREEN SHEETS

Specifications:

Open coat resin on resin bond.

Best For: Concrete or ceramic tile.

Tool: Power Sanders.



ABRASIVE FILE SHEETS

Specifications:

Aluminum Oxide with 3 different backings.

Best For: Auto body or flat surface sanding.

Tool: Long board sanders.

COLOR CHART



BROWN
COARSE



BURGUNDY
MEDIUM

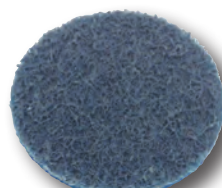

BLUE
FINE



GREY
ULTRA-FINE



BROWN/BLUE BACK
EXTRA COARSE

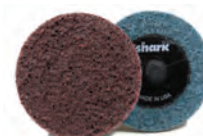

BURGUNDY/BLUE BACK
HEAVY-DUTY MEDIUM

SURFACE CONDITIONING



Thicker,
Longer
Lasting
Material



Specifications:
The Twist-To-Lock feature is great for quick-change and is compatible with all other brands of twist locking style holders.



STAR-BRITE SUPERIOR LIFE SURFACE PREP DISCS

Item#	Old#	*3M#	Size	Color	Grit	Pk. Qty.	MP
610TB		37454	1 ½"	Brown	Coarse	25	4
612TB		37462	1 ½"	Burgundy	Medium	25	4
614TB		37470	1 ½"	Blue	Fine	25	4
616TB		37488	1 ½"	Grey	Ultra-Fine	25	4
13000		07480	2"	Brown	Coarse	10	8
13062	620TB	07480	2"	Brown	Coarse	25	8
13003	620TB-50	07480	2"	Brown	Coarse	50	10
13219	620TBC	07480	2"	Brown	Coarse	100	10
620TB-500		07480	2"	Brown	Coarse	500	2
620TB-1000		07480	2"	Brown	Coarse	1000	1
621TB		92679	2"	Brown	Extra Coarse	25	4
621TB-50		92679	2"	Brown	Extra Coarse	50	5
621TBC		92679	2"	Brown	Extra Coarse	100	5
13001		07481	2"	Burgundy	Medium	10	8
13018	622TB	07481	2"	Burgundy	Medium	25	4
13004	622TB-50	07481	2"	Burgundy	Medium	50	10
13220	622TBC	07481	2"	Burgundy	Medium	100	10
622TB-500		07481	2"	Burgundy	Medium	500	2
622TB-1000		07481	2"	Burgundy	Medium	1000	1
623TB		83987	2"	Burgundy	Heavy Duty Medium	25	4
623TB-50		83987	2"	Burgundy	Heavy Duty Medium	50	5
623TBC		83987	2"	Burgundy	Heavy Duty Medium	100	5
13002		07515	2"	Blue	Fine	10	8
624TB		07515	2"	Blue	Fine	25	4
13005	624TB-50	07515	2"	Blue	Fine	50	10
13221	624TBC	07515	2"	Blue	Fine	100	10
624TB-500		07515	2"	Blue	Fine	500	2
624TB-1000		07515	2"	Blue	Fine	1000	1
626TB		07516	2"	Grey	Ultra-Fine	25	4
626TB-50		07516	2"	Grey	Ultra-Fine	50	10
626TBC		07516	2"	Grey	Ultra-Fine	100	10
626TB-1000		07516	2"	Grey	Ultra-Fine	1000	1
13006		07485	3"	Brown	Coarse	10	8
13019	630TB	07485	3"	Brown	Coarse	25	4
13222	630TB-50	07485	3"	Brown	Coarse	50	10
13223	630TBC	07485	3"	Brown	Coarse	100	5

*3M is a Registered Trademark of 3M Corporation.

(Continued)



SURFACE CONDITIONING



620TB

STAR-BRITE SUPERIOR LIFE SURFACE PREP DISCS

Item#	Old#	**3M#	Size	Color	Grit	Pk. Qty.	MP
630TB-1000		07485	3"	Brown	Coarse	1000	1
631TB		92695	3"	Brown	X-tra Coarse	25	10
631TB-50		92695	3"	Brown	X-tra Coarse	50	10
631TBC		92695	3"	Brown	X-tra Coarse	100	5
13007		07486	3"	Burgundy	Medium	10	10
13020	632TB	07486	3"	Burgundy	Medium	25	10
13224	632TB-50	07486	3"	Burgundy	Medium	50	5
13225	632TBC	07486	3"	Burgundy	Medium	100	5
632TB-500		07486	3"	Burgundy	Medium	500	1
632TB-1000		07486	3"	Burgundy	Medium	1000	1
633TB		83995	3"	Burgundy	Heavy Duty Medium	25	10
633TB-50		83995	3"	Burgundy	Heavy Duty Medium	50	10
633TBC		83995	3"	Burgundy	Heavy Duty Medium	100	5
13008		07513	3"	Blue	Fine	10	10
634TB		07513	3"	Blue	Fine	25	10
634TB-50		07513	3"	Blue	Fine	50	10
634TBC		07513	3"	Blue	Fine	100	5
634TB-1000		07513	3"	Blue	Fine	1000	1
636TB		07514	3"	Grey	Ultra-Fine	25	10
636TB-50		07514	3"	Grey	Ultra-Fine	50	10
636TBC		07514	3"	Grey	Ultra-Fine	100	5
636TB-1000		07514	3"	Grey	Ultra-Fine	1000	1
13009		07482	4"	Brown	Coarse	10	5
640TB		07482	4"	Brown	Coarse	25	4
640TB-50		07482	4"	Brown	Coarse	50	4
640TBC		07482	4"	Brown	Coarse	100	2
13010		21274	4"	Burgundy	Medium	10	5
642TB		07484	4"	Burgundy	Medium	25	4
642TB-50		07484	4"	Burgundy	Medium	50	4
642TBC		07484	4"	Burgundy	Medium	100	2
644TB		07511	4"	Blue	Fine	10	5
13011	646TB	07512	4"	Grey	Ultra-Fine	10	5
64520TB*		52162	4 ½"	Brown	Coarse	10	5
64522TB*		23688	4 ½"	Burgundy	Medium	10	5
64524TB*			4 ½"	Blue	Fine	10	5
64526TB*			4 ½"	Grey	Ultra-Fine	10	5
6520TB*		21282	5"	Brown	Coarse	10	5
6522TB*		34053	5"	Burgundy	Medium	10	5
6524TB*			5"	Blue	Fine	10	5
6526TB*			5"	Grey	Ultra-Fine	10	5

*Hook and Loop

**3M is a Registered Trademark of 3M Corporation.

SURFACE CONDITIONING



STAR-BRITE SUPERIOR LIFE SURFACE PREP DISCS

Item#	**3M#	Size	Color	Grit	Pk. Qty.	MP
6620TB*	35408	6"	Brown	Coarse	10	5
6622TB*	45869	6"	Burgundy	Medium	10	5
6624TB*		6"	Blue	Fine	10	5
6720TB*	07943	7"	Brown	Coarse	10	5
6722TB*	23312	7"	Burgundy	Medium	10	5
6724TB*	53384	7"	Blue	Fine	10	5
6726TB*		7"	Grey	Ultra-Fine	10	5



Specifications:

These premium pads are softer, with a less aggressive performance.

Backing Type: Twist-to-lock

STAR-BRITE PREMIUM PADS

Item#	**3M#	Size	Color	Grit	Pk. Qty.	MP
610T	37454	1 1/2"	Brown	Coarse	25	4
610T-100	37454	1 1/2"	Brown	Coarse	100	5
612T	37462	1 1/2"	Burgundy	Medium	25	4
612T-100	37462	1 1/2"	Burgundy	Medium	100	5
614T	37470	1 1/2"	Blue	Fine	25	4
614T-100	37470	1 1/2"	Blue	Fine	100	1
614T-1000	37470	1 1/2"	Blue	Fine	1000	1
620T	07480	2"	Brown	Coarse	25	4
620T-50	07480	2"	Brown	Coarse	50	10
620TC	07480	2"	Brown	Coarse	100	10
620T-500	07480	2"	Brown	Coarse	500	2
620T-1000	07480	2"	Brown	Coarse	1000	1
622T	07481	2"	Burgundy	Medium	25	4
622T-50	07481	2"	Burgundy	Medium	50	10
622TC	07481	2"	Burgundy	Medium	100	1
622T-500	07481	2"	Burgundy	Medium	500	2
622T-1000	07481	2"	Burgundy	Medium	1000	1
624T	07515	2"	Blue	Fine	25	4
624T-50	07515	2"	Blue	Fine	50	10
624TC	07515	2"	Blue	Fine	100	10
624T-500	07515	2"	Blue	Fine	500	2
624T-1000	07515	2"	Blue	Fine	1000	1

*Hook and Loop

**3M is a Registered Trademark of 3M Corporation.



SURFACE CONDITIONING

STAR-BRITE PREMIUM PADS

Less aggressive than the TB series, these USA made pads offer more flexibility and a softer disc, provides a high quality user experience.



Item#	*3M#	Size	Color	Grit	Pk. Qty.	MP
626T	07515	2"	● Grey	Ultra Fine	25	4
626T-50	07515	2"	● Grey	Ultra Fine	50	10
626TC	07515	2"	● Grey	Ultra Fine	100	2
626T-500	07515	2"	● Grey	Ultra Fine	500	1
626T-1000	07515	2"	● Grey	Ultra Fine	1000	1
630T	07485	3"	● Brown	Coarse	25	4
630T-50	07485	3"	● Brown	Coarse	50	10
630TC	07485	3"	● Brown	Coarse	100	5
630T-500	07485	3"	● Brown	Coarse	500	1
630T-1000	07485	3"	● Brown	Coarse	1000	1
632T	07486	3"	● Burgundy	Medium	25	4
632T-50	07486	3"	● Burgundy	Medium	50	10
632TC	07486	3"	● Burgundy	Medium	100	5
632T-500	07486	3"	● Burgundy	Medium	500	1
632T-1000	07486	3"	● Burgundy	Medium	1000	1
634T	07513	3"	● Blue	Fine	25	4
634T-50	07513	3"	● Blue	Fine	50	2
634TC	07513	3"	● Blue	Fine	100	2
634T-500	07513	3"	● Blue	Fine	500	1
634T-1000	07513	3"	● Blue	Fine	1000	1
636T	07514	3"	● Grey	Ultra Fine	25	4
636T-50	07514	3"	● Grey	Ultra Fine	50	2
636TC	07514	3"	● Grey	Ultra Fine	100	2
636T-500	07514	3"	● Grey	Ultra Fine	500	1
636T-1000	07514	3"	● Grey	Ultra Fine	1000	1
640T	07482	4"	● Brown	Coarse	25	4
640T-50	07482	4"	● Brown	Coarse	50	2
640TC	07482	4"	● Brown	Coarse	100	2
640T-500	07482	4"	● Brown	Coarse	500	1
640T-1000	07482	4"	● Brown	Coarse	1000	1
642T	07483	4"	● Burgundy	Medium	25	4
642T-50	07483	4"	● Burgundy	Medium	50	2
642TC	07483	4"	● Burgundy	Medium	100	2
642T-500	07483	4"	● Burgundy	Medium	500	1
642T-1000	07483	4"	● Burgundy	Medium	1000	1
644T	07511	4"	● Blue	Fine	10	5
644TC	07511	4"	● Blue	Fine	100	2
646T	07512	4"	● Grey	Ultra Fine	10	5
646TC	07512	4"	● Grey	Ultra Fine	100	2

*3M is a Registered Trademark of 3M Corporation.

SURFACE PREP/GRINDING

STAR-BRITE/MINI GRINDING CLAMSHELL PACKAGES

Shark has compiled 6 prime clamshell display packages. These kits have great 4 color packaging that will stand out on the display shelves. The 6 kits are created of several different types of mini grinding discs and star-brite discs.



STAR-BRITE FINISHING KITS 2" & 3"

The Surface Conditioning Discs provide a burr-free finish while removing grinding marks, rust and surface coatings, while the professional Grinding Discs provide a fast, efficient method of grinding, blending, leveling and finishing metal surfaces.

Item#	Description	Item#	Description
16401	2" Mini Grinding Assortment	16402	3" Mini Grinding Assortment
This 6 pcs Surface Prep Assortment kit includes the following:		This 6 pcs Surface Prep Assortment kit includes the following:	
(1) 2" Coarse Disc		(1) 3" Coarse Disc	
(1) 2" Medium Disc		(1) 3" Medium Disc	
(1) 2" 24 Grit Mini Grinding Disc		(1) 3" 24 Grit Mini Grinding Disc	
(1) 2" 36 Grit Mini Grinding Disc		(1) 3" 36 Grit Mini Grinding Disc	
(1) 2" 50 Grit Mini Grinding Disc		(1) 3" 50 Grit Mini Grinding Disc	
(1) 2" Holder		(1) 3" Holder	

Item#	Description
620TBA	Surface Prep Assortment
This 26 pcs Surface Prep Assortment kit includes the following: (12) 2" Coarse Discs, (10) 2" Medium Discs, (3) 2" Fine Discs and (1) 2" Holder	
6200	Surface Prep Assortment
This 20 pcs Surface Prep Assortment kit includes the following: (10) 2" Coarse Discs, (8) 2" Medium Discs and (2) 2" Fine Discs	

MINI GRINDING/STAR-BRITE ASSORTMENT KIT

Item#	Description	Item#	Description
6300	2" Assortment Kit	6400	2" & 3" Assortment Kit
This 20 pcs Mini Grinding Assortment kit includes:		This 20 pcs Surface Prep/Mini Grinding Assortment kit includes:	
(8) 2" 24 Grit Mini Grinding Disc		(4) 2" Coarse Disc	
(5) 2" 36 Grit Mini Grinding Disc		(4) 3" Coarse Disc	
(5) 2" 50 Grit Mini Grinding Disc		(4) 2" 24 Grit Mini Grinding Disc	
(2) 2" 80 Grit Mini Grinding Disc		(4) 2" 36 Grit Mini Grinding Disc	
		(4) 2" 50 Grit Mini Grinding Disc	





SURFACE PREP/GRINDING KITS

STAR-BRITE SURFACE PREP ASSORTMENT KIT

This set is perfect for sanding jobs in the paint shops. For use when preparing a car body prior to painting, this kit will accommodate a full range of customer needs.



S6600

S6600 Kit Includes

Item#	Qty.	Description
6666T	1	Angle Head Air Tool (Taiwan)
13062-1	3	2" Coarse Star-Brite Discs
13018-1	3	2" Medium Star-Brite Discs
13019-1	3	3" Coarse Star-Brite Discs
13020-1	3	3" Medium Star-Brite Discs
13012	1	2" Twist-to-Lock Holder
13013	1	3" Twist-to-Lock Holder
A25S	1	Salmon Mounted Point
W178S	1	Salmon Mounted Point
W236S	1	Salmon Mounted Point
13109-1	1	1 1/2" x 1" - 40 Grit Flap Wheel
13110-1	1	1 1/2" x 1/2" - 60 Grit Flap Wheel

ANGLE HEAD AIR TOOL

Angled head design allows user to get into tight spaces. Designed for 2" and 3" holders.

Item#	Description	Wt.	Dimension
6666T	Shark Angle Head Air Tool Made in Taiwan	1.25 lb.	3" x 7" x 2"

SANDING AND STAR-BRITE ASSORTMENT KIT

For sanding and surface prep before painting cars in body shops.



S6650

S6650 Kit Includes

Item#	Qty.	Description
6666T	1	Angle Head Air Tool (Taiwan)
13227-1	2	2" Aluminum Oxide Discs Coarse 36 grit
13229-1	1	2" Aluminum Oxide Discs Medium 80 grit
13235-1	2	3" Aluminum Oxide Discs Coarse 36 grit
13237-1	1	3" Aluminum Oxide Discs Medium 80-grit
13062-1	2	2" Coarse Star-Brite Discs
13018-1	1	2" Medium Star-Brite Discs
13019-1	2	3" Coarse Star-Brite Discs
13020-1	1	3" Medium Star-Brite Discs
13012	1	2" Twist-to-Lock Holder
13013	1	3" Twist-to-Lock Holder
A25S	1	Salmon Mounted Point
W178S	1	Salmon Mounted Point
W236S	1	Salmon Mounted Point
13109-1	1	1 1/2" x 1" - 40 Grit Flap Wheel
13110-1	1	1 1/2" x 1/2" - 60 Grit Flap Wheel



Uses all 1/4" Shaft Holders.
Twist-to-Lock Holders

SURFACE PREP/GRINDING

STAR-BRITE POLISHING DISC TYPE 27

This depressed center polishing disc is used for polishing on flat surfaces and edge cleaning. Provides excellent surface finishes on Stainless Steel.

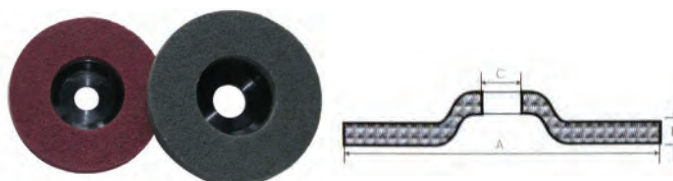

Item#	Length	Width	Color	Grit	Style	Pk. Qty	MP
14601	4"	5/8"	Maroon	Coarse	Polishing Disc	1	10
14602	4 1/2"	7/8"	Maroon	Coarse	Polishing Disc	1	10
14603	4"	5/8"	Grey	Medium	Polishing Disc	1	10
14604	4 1/2"	7/8"	Grey	Medium	Polishing Disc	1	10



Specifications:

Non woven pads impregnated with resin and grain for many applications.

Best For: Hand sanding on parts and rust.

STAR-BRITE SANDING PADS

Item#	*3M#	Length	Width	Color	Grit	Style	Pk. Qty	MP
13015	07445	6"	9"	White	Cleaning	Sanding Pads	10 Pads	10
13016	07448	6"	9"	Grey	Ultra Fine	Sanding Pads	10 Pads	10
13017	07447	6"	9"	Maroon	Medium	Sanding Pads	10 Pads	10
13073 - 20 Pack		6"	9"	Maroon	Medium	Sanding Pads	20 Pads	5
13074 - 20 Pack		6"	9"	Grey	Ultra Fine	Sanding Pads	20 Pads	5
13075 - 20 Pack		6"	9"	10 Maroon & 10 Grey	Medium/Ultra Fine	Sanding Pads	20 Pads	5



STRIP-BRITE DISCS TYPE 27

Specifications:

Mounted on a depressed center backing plate. Use when grinding on flat or convex surfaces when removing rust or paint. It will not distort or disturb the metal.

Item#	Size	Arbor	Color	Grit	Style	Pk. Qty	MP
14605	4 1/2"	7/8"	Red	Coarse	Strip-Brite Disc	1	5
14606	4 1/2"	7/8"	Black	Medium	Strip-Brite Disc	1	5
16208	4 1/2"	7/8"	Purple	Extra Coarse	Strip-Brite Disc	1	5
16209	7"	7/8"	Purple	Extra Coarse	Strip-Brite Disc	1	5

STRIP-BRITE DISC TYPE 1



Specifications:

Mounted on the 12782 mandrel, the disc is designed to be used on the edge for rust or paint removal in gutters, depressions, or concave areas when it is not desired to distort or change the metal dimensions.

Item#	Size	Arbor	Color	Grit	Style	Pk. Qty	MP
14607	4 x 1/2"	7/16"	Red	Coarse	Strip-Brite Disc	1	5
12782	7/16"	Arbor Hole			Mandrel for 14607	1	5

*3M is a Registered Trademark of 3M Corporation.



MINI GRINDING

STRIP-BRITE PADS

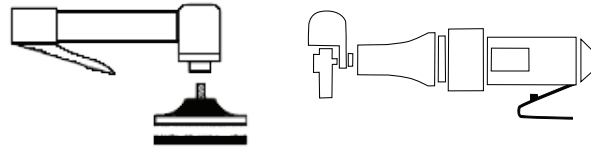

Tool: Right Angle Grinders or Die Grinders.

These discs are typically used for paint or coating removal and feature the quick and easy twist-to-lock attachment system. The disc is an open-web construction impregnated with silicon carbide to provide aggressive and long-lasting performance. The extremely durable, three-dimensional web has a soft edge, allowing it to remove paint and other coatings in those unreachable creases and dents while removing very little metal. Great for stripping paint without damaging metal especially on aluminum.



BLACK
Good
For least aggressive grinding.



RED
Better
Medium Life Grinding

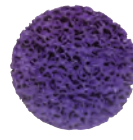

PURPLE
Best
Longest Life Grinding

Backing Type:
Twist-to-lock



Item#	Size	Pk. Qty
6202	2"	2
6205	2"	5
6206	2"	10
6302	3"	2
6305	3"	5
6306	3"	10

Item#	Size	Pk. Qty
16202	2"	5
16201	2"	10
16203	3"	2
16204	3"	5
16205	3"	10

Item#	Size	Pk. Qty
16206	2"	5
16210	2"	10
16207	3"	5
16211	3"	10
*16208	4 1/2" x 7/8"	1
*16209	7" x 7/8"	1

*Type 27 - 7/8" hole.

CLOTH BACKED MINI GRINDING DISCS

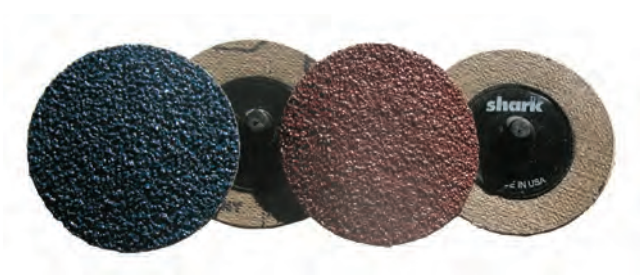

Specifications:

Cloth-backed sanding/grinding discs are available in Aluminum Oxide or Zirconia. The cloth backing makes the disc softer and is good for less aggressive sanding/grinding applications.

Tool: Right Angle Grinders or Die Grinders.

Best For: Aluminum Oxide:

Any sanding or grinding application on steel or bondo.

Zirconia:

Any sanding or grinding application on stainless steel.

ALUMINUM OXIDE CLOTH BACKED GRINDING DISCS

Item#	Size	Grit	Grain	Pk. Qty
43220	2"	24	Aluminum Oxide	25
43221	2"	36	Aluminum Oxide	25
43222	2"	60	Aluminum Oxide	25
43223	2"	80	Aluminum Oxide	25
43224	2"	120	Aluminum Oxide	25
43225	3"	24	Aluminum Oxide	25
43226	3"	36	Aluminum Oxide	25
43227	3"	60	Aluminum Oxide	25
43228	3"	80	Aluminum Oxide	25
43229	3"	120	Aluminum Oxide	25

ZIRCONIA CLOTH BACKED MINI GRINDING DISCS

Item#	Size	Grit	Grain	Pk. Qty
44220	2"	24	Zirconia	25
44221	2"	36	Zirconia	25
44222	2"	50	Zirconia	25
44223	2"	80	Zirconia	25
44224	2"	120	Zirconia	25
44225	3"	24	Zirconia	25
44226	3"	36	Zirconia	25
44227	3"	50	Zirconia	25
44228	3"	80	Zirconia	25
44229	3"	120	Zirconia	25

MINI GRINDING

GREEN ZIRCONIA MINI GRINDING DISCS

2"



Item#	Size	Grit	Style	Pk. Qty
12612	2"	24	Green Zirconia	25
12613	2"	36	Green Zirconia	25
12614	2"	50	Green Zirconia	25
12615	2"	80	Green Zirconia	25

Longer life than Zirconia or Aluminum Oxide discs, these are great for a multitude of uses where a heavy duty abrasive is required. Excels on extra hard metals such as stainless steel.

3"



Item#	Size	Grit	Style	Pk. Qty
12616	3"	24	Green Zirconia	25
12617	3"	36	Green Zirconia	25
12618	3"	50	Green Zirconia	25
12619	3"	80	Green Zirconia	25

CERAMIC MINI GRINDING DISCS

2"



Item#	Size	Grit	Style	Pk. Qty
12621	2"	24	Ceramic	25
12622	2"	36	Ceramic	25
12623	2"	40	Ceramic	25
12624	2"	50	Ceramic	25
12625	2"	60	Ceramic	25
12626	2"	80	Ceramic	25
12634	2"	120	Ceramic	25

3"



Item#	Size	Grit	Style	Pk. Qty
12627	3"	24	Ceramic	25
12628	3"	36	Ceramic	25
12629	3"	40	Ceramic	25
12630	3"	50	Ceramic	25
12631	3"	60	Ceramic	25
12632	3"	80	Ceramic	25
12633	3"	120	Ceramic	25

Ceramic is the longest life grain available. This product has a laminated, tough backing for extra longevity. It eliminates the shredding or snagging you will experience with pressure sensitive discs. Use for grinding and finishing of stainless steel, high alloy steels, chrome, nickel and titanium.





MINI GRINDING DISCS



ALUMINUM OXIDE/RESIN BACKED 2" & 3" MINI GRINDING DISCS

Specifications:

Premium Aluminum Oxide grit bonded onto tough resin backing offers a very durable disc.

Best For: Weld grinding and finishing on steel & metals.

Tool: For use with angle and die grinders.

Item#	Old#	Size	Grit	Grain	Pk. Qty	MP
12840		2"	24	Aluminum Oxide	10	10
13226	3220GT	2"	24	Aluminum Oxide	25	4
13230	3220GT-50	2"	24	Aluminum Oxide	50	10
3220GT-100		2"	24	Aluminum Oxide	100	5
12841		2"	36	Aluminum Oxide	10	10
13227	3230GT	2"	36	Aluminum Oxide	25	4
13231	3230GT-50	2"	36	Aluminum Oxide	50	10
3230GT-100		2"	36	Aluminum Oxide	100	5
12842		2"	50	Aluminum Oxide	10	10
13228	3250GT	2"	50	Aluminum Oxide	25	4
13232	3250GT-50	2"	50	Aluminum Oxide	50	10
3250GT-100		2"	50	Aluminum Oxide	100	5
12843		2"	80	Aluminum Oxide	10	10
13229	3280GT	2"	80	Aluminum Oxide	25	4
13233	3280GT-50	2"	80	Aluminum Oxide	50	10
3280GT-100		2"	80	Aluminum Oxide	100	5
32120GT		2"	120	Aluminum Oxide	25	4
12844		3"	24	Aluminum Oxide	10	10
13234	3320GT	3"	24	Aluminum Oxide	25	4
13238		3"	24	Aluminum Oxide	50	10
3320GT-100		3"	24	Aluminum Oxide	100	5
12845		3"	36	Aluminum Oxide	10	10
13235	3330GT	3"	36	Aluminum Oxide	25	4
13239		3"	36	Aluminum Oxide	50	10
3330GT-100		3"	36	Aluminum Oxide	100	5
12846		3"	50	Aluminum Oxide	10	10
13236	3350GT	3"	50	Aluminum Oxide	25	4
13240		3"	50	Aluminum Oxide	50	10
3350GT-100		3"	50	Aluminum Oxide	100	5
12847		3"	80	Aluminum Oxide	10	10
13237	3380GT	3"	80	Aluminum Oxide	25	4
13241		3"	80	Aluminum Oxide	50	10
3380GT-100		3"	80	Aluminum Oxide	100	5
33120GT		3"	120	Aluminum Oxide	25	4

MINI GRINDING DISCS

ZIRCONIA RESIN BACKED 2" & 3" MINI GRINDING DISCS

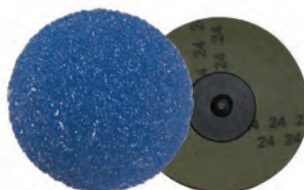

Specifications:

Zirconia long-life grain for Stainless Steel or regular steels.

Best For: Weld grinding and finishing on Stainless Steel.

Tool: For use with angle grinders or die grinders.

Item#	Old#	Size	Grit	Grain	Pk. Qty	MP
13242	3220ZGT	2"	24	Zirconia	25	4
13246		2"	24	Zirconia	50	10
13243	3230ZGT	2"	36	Zirconia	25	4
13247	3230ZGT-50	2"	36	Zirconia	50	10
13244	3250ZGT	2"	50	Zirconia	25	4
13248	3250ZGT-50	2"	50	Zirconia	50	10
13245	3280ZGT	2"	80	Zirconia	25	4
13249		2"	80	Zirconia	50	10
13258	32120ZGT	2"	120	Zirconia	25	4
13250	3320ZGT	3"	24	Zirconia	25	4
13254		3"	24	Zirconia	50	10
13251	3330ZGT	3"	36	Zirconia	25	4
13255		3"	36	Zirconia	50	10
13252	3350ZGT	3"	50	Zirconia	25	4
13256	3350ZGT-50	3"	50	Zirconia	50	10
13253	3380ZGT	3"	80	Zirconia	25	4
13257	3380ZGT-50	3"	80	Zirconia	50	10
13259	33120ZGT	3"	120	Zirconia	25	4





4" - 5" RESIN FIBER GRINDING DISCS

Specifications:

Premium Aluminum Oxide grit bonded onto tough resin backing offers a very durable disc.

Best For: Weld grinding, auto body work and general steel grinding.

Tool: 4" - 9" angle grinders



ALUMINUM OXIDE RESIN FIBER DISCS

Item#	Old#	Size	Arbor	Grit	Grain	RPM	Pk. Qty	MP
12805	40160-3	4"	5/8"	16	Aluminum Oxide	15,300	3	10
40160		4"	5/8"	16	Aluminum Oxide	15,300	25	4
12806	40240-3	4"	5/8"	24	Aluminum Oxide	15,300	3	10
40240		4"	5/8"	24	Aluminum Oxide	15,300	25	4
12807	40360-3	4"	5/8"	36	Aluminum Oxide	15,300	3	10
40360		4"	5/8"	36	Aluminum Oxide	15,300	25	4
12808	40500-3	4"	5/8"	50	Aluminum Oxide	15,300	3	10
40500		4"	5/8"	50	Aluminum Oxide	15,300	25	4
12809	40800-3	4"	5/8"	80	Aluminum Oxide	15,300	3	10
40800		4"	5/8"	80	Aluminum Oxide	15,300	25	4
12810	40100-3	4"	5/8"	100	Aluminum Oxide	15,300	3	10
40100		4"	5/8"	100	Aluminum Oxide	15,300	25	4
12811	40120-3	4"	5/8"	120	Aluminum Oxide	15,300	3	10
40120		4"	5/8"	120	Aluminum Oxide	15,300	25	4
12812	45160-3	4 1/2"	7/8"	16	Aluminum Oxide	13,300	3	10
45160		4 1/2"	7/8"	16	Aluminum Oxide	13,300	25	8
12813	45240-3	4 1/2"	7/8"	24	Aluminum Oxide	13,300	3	10
45240		4 1/2"	7/8"	24	Aluminum Oxide	13,300	25	8
45240C		4 1/2"	7/8"	24	Aluminum Oxide	13,300	100	4
12814	45360-3	4 1/2"	7/8"	36	Aluminum Oxide	13,300	3	10
45360		4 1/2"	7/8"	36	Aluminum Oxide	13,300	25	8
12815	45500-3	4 1/2"	7/8"	50	Aluminum Oxide	13,300	3	10
45500		4 1/2"	7/8"	50	Aluminum Oxide	13,300	25	8
12816	45800-3	4 1/2"	7/8"	80	Aluminum Oxide	13,300	3	10
45800		4 1/2"	7/8"	80	Aluminum Oxide	13,300	25	8
12817	45100-3	4 1/2"	7/8"	100	Aluminum Oxide	13,300	3	10
45100		4 1/2"	7/8"	100	Aluminum Oxide	13,300	25	8
12818	45120-3	4 1/2"	7/8"	120	Aluminum Oxide	13,300	3	10
45120		4 1/2"	7/8"	120	Aluminum Oxide	13,300	25	8
12819	50160-3	5"	7/8"	16	Aluminum Oxide	12,250	3	10
50160		5"	7/8"	16	Aluminum Oxide	12,250	25	8
12820	50240-3	5"	7/8"	24	Aluminum Oxide	12,250	3	10
50240		5"	7/8"	24	Aluminum Oxide	12,250	25	8
50240C		5"	7/8"	24	Aluminum Oxide	12,250	100	4
12821	50360-3	5"	7/8"	36	Aluminum Oxide	12,250	3	10
50360		5"	7/8"	36	Aluminum Oxide	12,250	25	8
50360C		5"	7/8"	36	Aluminum Oxide	12,250	100	4

5"- 9" RESIN FIBER GRINDING DISCS

ALUMINUM OXIDE RESIN FIBER DISCS

Item#	Old#	Size	Arbor	Grit	Grain	RPM	Pk. Qty	MP
12822	50500-3	5"	7/8"	50	Aluminum Oxide	12,250	3	10
50500		5"	7/8"	50	Aluminum Oxide	12,250	25	8
12823	50800-3	5"	7/8"	80	Aluminum Oxide	12,250	3	10
50800		5"	7/8"	80	Aluminum Oxide	12,250	25	8
12824	50100-3	5"	7/8"	100	Aluminum Oxide	12,250	3	10
50100		5"	7/8"	100	Aluminum Oxide	12,250	25	8
12825	50120-3	5"	7/8"	120	Aluminum Oxide	12,250	3	10
50120		5"	7/8"	120	Aluminum Oxide	12,250	25	8
12826	70160-3	7"	7/8"	16	Aluminum Oxide	8,500	3	10
70160		7"	7/8"	16	Aluminum Oxide	8,500	25	8
12827	70240-3	7"	7/8"	24	Aluminum Oxide	8,500	3	10
70240		7"	7/8"	24	Aluminum Oxide	8,500	25	8
70240C		7"	7/8"	24	Aluminum Oxide	8,500	100	2
12828	70360-3	7"	7/8"	36	Aluminum Oxide	8,500	3	10
70360		7"	7/8"	36	Aluminum Oxide	8,500	25	8
70360C		7"	7/8"	36	Aluminum Oxide	8,500	100	2
12829	70500-3	7"	7/8"	50	Aluminum Oxide	8,500	3	10
70500		7"	7/8"	50	Aluminum Oxide	8,500	25	8
70600		7"	7/8"	60	Aluminum Oxide	8,500	25	8
12830	70800-3	7"	7/8"	80	Aluminum Oxide	8,500	3	10
70800		7"	7/8"	80	Aluminum Oxide	8,500	25	8
12831	70100-3	7"	7/8"	100	Aluminum Oxide	8,500	3	10
70100		7"	7/8"	100	Aluminum Oxide	8,500	25	8
12832	70120-3	7"	7/8"	120	Aluminum Oxide	8,500	3	10
70120		7"	7/8"	120	Aluminum Oxide	8,500	25	8
12833	90160-3	9"	7/8"	16	Aluminum Oxide	6,650	3	10
90160		9"	7/8"	16	Aluminum Oxide	6,650	25	8
12834	90240-3	9"	7/8"	24	Aluminum Oxide	6,650	3	10
90240		9"	7/8"	24	Aluminum Oxide	6,650	25	8
12835	90360-3	9"	7/8"	36	Aluminum Oxide	6,650	3	10
90360		9"	7/8"	36	Aluminum Oxide	6,650	25	8
12836	90500-3	9"	7/8"	50	Aluminum Oxide	6,650	3	10
90500		9"	7/8"	50	Aluminum Oxide	6,650	25	8
12837	90800-3	9"	7/8"	80	Aluminum Oxide	6,650	3	10
90800		9"	7/8"	80	Aluminum Oxide	6,650	25	8
12838	90100-3	9"	7/8"	100	Aluminum Oxide	6,650	3	10
90100		9"	7/8"	100	Aluminum Oxide	6,650	25	8
12839		9"	7/8"	120	Aluminum Oxide	6,650	3	10
90120		9"	7/8"	120	Aluminum Oxide	6,650	25	8

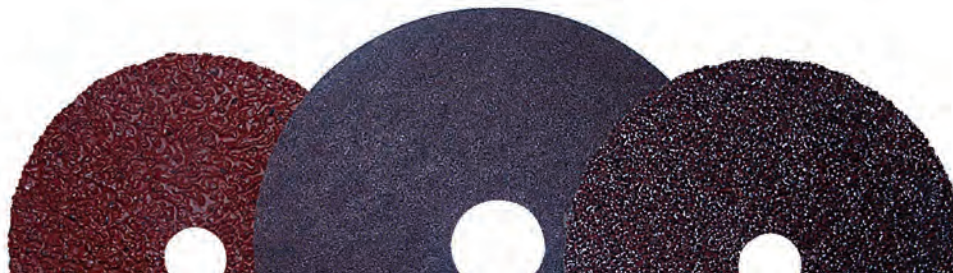



RESIN FIBER GRINDING DISCS

Specifications:

Tough Zirconia grain with resins on a rugged fiber backing offers aggressive long-life grinding.

Best For: Grinding welds, auto body work and Stainless Steel.

Tool: 4" - 9" Angle Grinders



4" - 7" ZIRCONIA RESIN FIBER DISCS

Item#	Size	Arbor	Grit	Grain	RPM	Pk. Qty	MP
40240Z-3	4"	5/8"	24	Zirconia	15,300	3	10
40240Z	4"	5/8"	24	Zirconia	15,300	25	8
40360Z-3	4"	5/8"	36	Zirconia	15,300	3	10
40360Z	4"	5/8"	36	Zirconia	15,300	25	8
40500Z-3	4"	5/8"	50	Zirconia	15,300	3	10
40500Z	4"	5/8"	50	Zirconia	15,300	25	8
40800Z-3	4"	5/8"	80	Zirconia	15,300	3	10
40800Z	4"	5/8"	80	Zirconia	15,300	25	8
45240Z-3	4 1/2"	7/8"	24	Zirconia	13,300	3	10
45240Z	4 1/2"	7/8"	24	Zirconia	13,300	25	8
45240ZC	4 1/2"	7/8"	24	Zirconia	13,300	100	2
45360Z-3	4 1/2"	7/8"	36	Zirconia	13,300	3	10
45360Z	4 1/2"	7/8"	36	Zirconia	13,300	25	8
45500Z-3	4 1/2"	7/8"	50	Zirconia	13,300	3	10
45500Z	4 1/2"	7/8"	50	Zirconia	13,300	25	8
45800Z-3	4 1/2"	7/8"	80	Zirconia	13,300	3	10
45800Z	4 1/2"	7/8"	80	Zirconia	13,300	25	8
50240Z-3	5"	7/8"	24	Zirconia	12,250	3	10
50240Z	5"	7/8"	24	Zirconia	12,250	25	8
50240C	5"	7/8"	24	Zirconia	12,250	100	2
50360Z-3	5"	7/8"	36	Zirconia	12,250	3	10
50360Z	5"	7/8"	36	Zirconia	12,250	25	8
50360ZC	5"	7/8"	36	Zirconia	12,250	100	2
50500Z-3	5"	7/8"	50	Zirconia	12,250	3	10
50500Z	5"	7/8"	50	Zirconia	12,250	25	8
50800Z-3	5"	7/8"	80	Zirconia	12,250	3	10
50800Z	5"	7/8"	80	Zirconia	12,250	25	8
70240Z-3	7"	7/8"	24	Zirconia	8,500	3	10
70240Z	7"	7/8"	24	Zirconia	8,500	25	4
70240ZC	7"	7/8"	24	Zirconia	8,500	100	2
70360Z-3	7"	7/8"	36	Zirconia	8,500	3	10
70360Z	7"	7/8"	36	Zirconia	8,500	25	4
70500Z-3	7"	7/8"	50	Zirconia	8,500	3	10
70500Z	7"	7/8"	50	Zirconia	8,500	25	4
70800Z-3	7"	7/8"	80	Zirconia	8,500	3	10
70800Z	7"	7/8"	80	Zirconia	8,500	25	4

RESIN FIBER GRINDING DISCS

9" ZIRCONIA RESIN FIBER DISCS

Item#	Size	Arbor	Grit	Grain	RPM	Pk. Qty	MP
90240Z-3	9"	7/8"	24	Zirconia	6,650	3	10
90240Z	9"	7/8"	24	Zirconia	6,650	25	8
90360Z-3	9"	7/8"	36	Zirconia	6,650	3	10
90360Z	9"	7/8"	36	Zirconia	6,650	25	8
90500Z-3	9"	7/8"	50	Zirconia	6,650	3	10
90500Z	9"	7/8"	50	Zirconia	6,650	25	8
90800Z-3	9"	7/8"	80	Zirconia	6,650	3	10
90800Z	9"	7/8"	80	Zirconia	6,650	25	8

PURE SHEEPSKIN AND WOOL MINI BUFFING BONNETS

These unique pads are velcro backed and made of pure wool and sheepskin for all your finishing jobs. Easily attaches to your angle grinder with a 1/4" mandrel backed velcro pad.

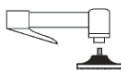

Item#	Description:	Pk. Qty
SK450	2" Sheepskin Bonnet	2
SK475	3" Sheepskin Bonnet	2

Item#	Description:	Pk. Qty
FT450	2" Wool Felt Pad For Compounding	2



Item#	Description:	Kit Includes:
SKA	2" Sheepskin Bonnet Kit	2 Pads & 1 Holder

Item#	Description:	Kit Includes:
FTA	2" Wool Felt Pad Kit	2 Pads & 1 Holder



SANDING SHEETS

ALUMINUM OXIDE GENERAL PURPOSE DRY SANDING SHEETS

Specifications:

Aluminum Oxide grit on a tough paper backing is designed to prevent loading when sanding. A great general purpose sheet for dry sanding applications on plastic, metal, wood, paint and fiberglass surfaces.

Best For: Any type of sanding including feather-edging, sanding scratches or paint removal.

Tool: Cut to fit power sanders, block or hand sanders as well as hand sanding.

Item#	Size	Grit	Grain	Pk. Qty
00036	9"x11"	36	Aluminum Oxide	100/Sleeve
00040	9"x11"	40	Aluminum Oxide	100/Sleeve
00060	9"x11"	60	Aluminum Oxide	100/Sleeve
00080	9"x11"	80	Aluminum Oxide	100/Sleeve
00100	9"x11"	100	Aluminum Oxide	100/Sleeve
00120	9"x11"	120	Aluminum Oxide	100/Sleeve
00150	9"x11"	150	Aluminum Oxide	100/Sleeve
00180	9"x11"	180	Aluminum Oxide	100/Sleeve
00220	9"x11"	220	Aluminum Oxide	100/Sleeve



SILICON CARBIDE WET/DRY PAPER

Specifications:

Silicon carbide moisture resistant sheets designed for a sharp cut and fine finish. Designed for wet or dry sanding applications such as lacquers, body fillers, glass, metal, plastic, stone or marble.

Best For: Use on lacquers, body fillers, glass, metal, plastic, stone and marble.

Tool: Cut to fit power sander, block or hand sanders as well as general hand sanding.



Item#	Size	Grit	Grain	Pk. Qty
15000	9"x11"	60	Silicon Carbide	50/Sleeve
15001	9"x11"	80	Silicon Carbide	50/Sleeve
15002	9"x11"	100	Silicon Carbide	50/Sleeve
15003	9"x11"	120	Silicon Carbide	50/Sleeve
15004	9"x11"	150	Silicon Carbide	50/Sleeve
15005	9"x11"	180	Silicon Carbide	50/Sleeve
15006	9"x11"	220	Silicon Carbide	50/Sleeve
15007	9"x11"	240	Silicon Carbide	50/Sleeve
15008	9"x11"	280	Silicon Carbide	50/Sleeve
15009	9"x11"	320	Silicon Carbide	50/Sleeve
15010	9"x11"	360	Silicon Carbide	50/Sleeve
15011	9"x11"	400	Silicon Carbide	50/Sleeve
15012	9"x11"	500	Silicon Carbide	50/Sleeve
15013	9"x11"	600	Silicon Carbide	50/Sleeve
15014	9"x11"	800	Silicon Carbide	50/Sleeve
15015	9"x11"	1000	Silicon Carbide	50/Sleeve
15016	9"x11"	1200	Silicon Carbide	50/Sleeve
15017	9"x11"	1500	Silicon Carbide	50/Sleeve
15018	9"x11"	2000	Silicon Carbide	50/Sleeve

SANDING SHEETS/SHOP ROLLS

SANDSCREEN SHEETS

Specifications:

Sandscreen sheets are an open-coat screen made with a silicon carbide grain. It's a resin on resin bond, long lasting, fast cutting and non-loading. Mesh-cloth backing can be cleaned and re-used.

Best For: Concrete, ceramic tiles and hardwood floors.

Tool: Power Sander.



Item#	Size	Grit	Grain	Pk. Qty
88000	4 ½"x11"	120	Sandscreen	50/Sleeve
88001	4 ½"x11"	100	Sandscreen	50/Sleeve
88002	4 ½"x11"	80	Sandscreen	50/Sleeve

EMERY CLOTH SHEETS

Specifications:

Natural emery grain on a flexible cloth backing that tears easily.

Best For: Sanding, polishing and rust removal.

Tool: For hand use.

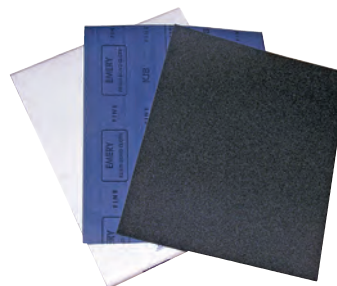

Item#	Size	Grit	Grain	Pk. Qty
80000	9"x11"	Fine	Emery Cloth	50/Sleeve
80001	9"x11"	Medium	Emery Cloth	50/Sleeve
80002	9"x11"	Coarse	Emery Cloth	50/Sleeve
80003	9"x11"	Extra Coarse	Emery Cloth	50/Sleeve

GENERAL PURPOSE EMERY CLOTH SHOP ROLLS

Specifications:

- Economical, easy tear-off, cotton "J" weight, resin bonded cloth rolls made with premium aluminum oxide grain.
- Self cut strips for hand sanding.
- Cleaning, deburring and polishing a wide variety of materials.



Item#	Size	Grit	Grain	Pk. Qty
12924	1" x 10 Yds.	80	Aluminum Oxide	1 Roll
12925	1" x 10 Yds.	120	Aluminum Oxide	1 Roll
12926	1" x 10 Yds.	180	Aluminum Oxide	1 Roll
12927	1" x 10 Yds.	320	Aluminum Oxide	1 Roll
12928	1" x 25 Yds.	80	Aluminum Oxide	1 Roll
12929	1" x 25 Yds.	120	Aluminum Oxide	1 Roll
12930	1" x 25 Yds.	180	Aluminum Oxide	1 Roll
12931	1" x 25 Yds.	320	Aluminum Oxide	1 Roll
12986	1" x 50 Yds.	60	Aluminum Oxide	1 Roll
12987	1" x 50 Yds.	80	Aluminum Oxide	1 Roll
12988	1" x 50 Yds.	100	Aluminum Oxide	1 Roll

Item#	Size	Grit	Grain	Pk. Qty
12989	1" x 50 Yds.	120	Aluminum Oxide	1 Roll
12990	1" x 50 Yds.	180	Aluminum Oxide	1 Roll
12998	1" x 50 Yds.	240	Aluminum Oxide	1 Roll
12991	1" x 50 Yds.	320	Aluminum Oxide	1 Roll
12997	1" x 50 Yds.	400	Aluminum Oxide	1 Roll
12992	1.5" x 50 Yds.	60	Aluminum Oxide	1 Roll
12993	1.5" x 50 Yds.	80	Aluminum Oxide	1 Roll
12994	1.5" x 50 Yds.	100	Aluminum Oxide	1 Roll
12995	1.5" x 50 Yds.	120	Aluminum Oxide	1 Roll
12996	1.5" x 50 Yds.	180	Aluminum Oxide	1 Roll
12999	1.5" x 50 Yds.	320	Aluminum Oxide	1 Roll



SUPER GOLD DISC ROLLS



Strong "C" weight backing on grits 150 and up and "D" weight on grits 40-120, this extra open coated.

Paper with a Resin bond and tough Aluminum Oxide will meet your demanding requirements. It has a stearate top coat for extended life. These discs offer long life, aggressive, sharp and fast cutting action.

Excellent for use on clear coats, putty, primers, wood and plastic applications.

Metals: Aluminum and Stainless Steel sanding.

PSA BACKING

PSA Style: Pressure Sensitive Adhesive for a tight hold.

	Item#	Size	Backing	Grit	Pk. Qty
3"	45095	3"	PSA	80	25
	45096	3"	PSA	100	25
	45097	3"	PSA	180	25
	45098	3"	PSA	220	25
	45099	3"	PSA	320	25
5"	23536*	5"	PSA	36	50
	23540*	5"	PSA	40	50
	23580	5"	PSA	80	100
	235100	5"	PSA	100	100
	235120	5"	PSA	120	100
	235150	5"	PSA	150	100
	235180	5"	PSA	180	100
	235220	5"	PSA	220	100
	235240	5"	PSA	240	100
	235320	5"	PSA	320	100
6"	235400	5"	PSA	400	100
	23636*	6"	PSA	36	50
	23640*	6"	PSA	40	50
	23680	6"	PSA	80	100
	236100	6"	PSA	100	100
	236120	6"	PSA	120	100
	236150	6"	PSA	150	100
	236180	6"	PSA	180	100
	236220	6"	PSA	220	100
	236240	6"	PSA	240	100
236320	6"	PSA	320	100	
236400	6"	PSA	400	100	

*Not linked rolls

VELCRO BACKING

Velcro Style: Easy and quick changeability. No adhesive to collect dust from grinding.

	Item#	Size	Backing	Grit	Pk. Qty
3"	45085	3"	Velcro	36	25
	45086	3"	Velcro	40	25
	45087	3"	Velcro	60	25
	45088	3"	Velcro	80	25
	45089	3"	Velcro	100	25
	45090	3"	Velcro	120	25
	45091	3"	Velcro	160	25
	45092	3"	Velcro	180	25
	45093	3"	Velcro	220	25
	45094	3"	Velcro	320	25
5"	23536V*	5"	Velcro	36	50
	23540V*	5"	Velcro	40	50
	23580V	5"	Velcro	80	100
	235100V	5"	Velcro	100	100
	235120V	5"	Velcro	120	100
	235150V	5"	Velcro	150	100
	235180V	5"	Velcro	180	100
	235220V	5"	Velcro	220	100
	235240V	5"	Velcro	240	100
	235320V	5"	Velcro	320	100
6"	235400V	5"	Velcro	400	100
	23636V*	6"	Velcro	36	50
	23640V*	6"	Velcro	40	50
	23680V	6"	Velcro	80	100
	236100V	6"	Velcro	100	100
	236120V	6"	Velcro	120	100
	236150V	6"	Velcro	150	100
	236180V	6"	Velcro	180	100
	236220V	6"	Velcro	220	100
	236240V	6"	Velcro	240	100
236320V	6"	Velcro	320	100	
236400V	6"	Velcro	400	100	

LONG BOARD SHEETS

ABRASIVE FILE SHEETS

Specifications:

File sheets for long boards are an economical abrasive that delivers "Best in Class" performance on a variety of substrates. This product allows for easy attachment and removal. It can be re-attached and used for sanding and shaping plastic filler.

Plain Backing, PSA Backing or Velcro Backing



PLAIN BACKING

Item#	Size	Grit	Pk. Qty
27036	2 3/4" x 17 1/2"	36	50
27040	2 3/4" x 17 1/2"	40	50
27060	2 3/4" x 17 1/2"	60	50
27080	2 3/4" x 17 1/2"	80	50
27120	2 3/4" x 17 1/2"	120	50
27150	2 3/4" x 17 1/2"	150	50

PSA BACKING

Item#	Size	Grit	Pk. Qty
24036	2 3/4" x 16 1/2"	36	50
24040	2 3/4" x 16 1/2"	40	50
24060	2 3/4" x 16 1/2"	60	50
24080	2 3/4" x 16 1/2"	80	50
24120	2 3/4" x 16 1/2"	120	50
24180	2 3/4" x 16 1/2"	180	50

VELCRO BACKING

Item#	Size	Grit	Pk. Qty
24036V	2 3/4" x 16 1/2"	36	50
24040V	2 3/4" x 16 1/2"	40	50
24060V	2 3/4" x 16 1/2"	60	50
24080V	2 3/4" x 16 1/2"	80	50
24120V	2 3/4" x 16 1/2"	120	50

EXTRA DURABLE ABRASIVE FILE PADS

Specifications:

This multi-purpose sanding sheet comes with a plain backing and is made of a long lasting aluminum oxide.

Best For: Sanding wood or steel.

Tool: Cut-to-fit power sanders or block sanders.



Item#	Size	Grit	Grain	Pk. Qty
13142	3" x 8"	36	Aluminum Oxide	100
13143	3" x 8"	40	Aluminum Oxide	100
13144	3" x 8"	80	Aluminum Oxide	100
13145	3" x 8"	120	Aluminum Oxide	100
13146	3" x 8"	150	Aluminum Oxide	100
13147	3" x 8"	180	Aluminum Oxide	100

PSA BACKED GOLD SANDING ROLLS

Specifications:

Cut to fit Gold Sanding rolls delivers fast, exceptionally long life that increases your productivity. Provides exceptional sanding performance, so you can get the job done fast; saving you time and money!

Best For: Shaping body filler, removing paint, rough feather edging, primer/metal sanding.

Tool: Pneumatic air files, hand sanding blocks, firm or flexible longboard file boards.



Item#	Size	Grit	Grain	Pk. Qty
12635	2 3/4" x 45 Yds	80	Aluminum Oxide	1 Roll
12636	2 3/4" x 45 Yds	120	Aluminum Oxide	1 Roll
12637	2 3/4" x 45 Yds	180	Aluminum Oxide	1 Roll
12638	2 3/4" x 45 Yds	320	Aluminum Oxide	1 Roll



SUPER BLUE DISCS

Super Blue, Polyester Film Discs

The NEW Shark Blue discs use Aluminum Oxide Grain on a Polyester film backing. Their Extra Open coating and Resin bonding also offers a Special Stearate top coat.

Excellent for use on polyurethanes, carbon fiber, polyesters, and acrylic resins. In Automotive applications, use with putty, primer and clear coat sanding. Also designed for use on polyester, acrylic and poly-acrylic, water and solvent-based paints.

Made in Italy.

VELCRO BACKING

Velcro Style: Easy and quick changeability. No adhesive to collect dust from grinding.

Item#	Size	Backing	Grit	Pk. Qty
23699	6"	Velcro	40	25
23700	6"	Velcro	60	25
23701	6"	Velcro	80	25
23702	6"	Velcro	100	25
23703	6"	Velcro	120	25
23704	6"	Velcro	150	25
23705	6"	Velcro	180	25
23706	6"	Velcro	220	25
23707	6"	Velcro	240	25
23708	6"	Velcro	320	25
23709	6"	Velcro	400	50
23710	6"	Velcro	500	50
23711	6"	Velcro	600	100
23712	6"	Velcro	800	100
23713	6"	Velcro	1000	100
23714	6"	Velcro	1200	100
23715	6"	Velcro	1500	100
23716	6"	Velcro	2000	100

6"

PSA BACKING

PSA Style: Pressure Sensitive Adhesive for a tight hold.

Item#	Size	Backing	Grit	Pk. Qty
23681	6"	PSA	40	50
23682	6"	PSA	60	50
23683	6"	PSA	80	50
23684	6"	PSA	100	100
23685	6"	PSA	120	100
23686	6"	PSA	150	100
23687	6"	PSA	180	100
23688	6"	PSA	220	100
23689	6"	PSA	240	100
23690	6"	PSA	320	100
23691	6"	PSA	400	100
23692	6"	PSA	500	100
23693	6"	PSA	600	100
23694	6"	PSA	800	100
23695	6"	PSA	1000	100
23696	6"	PSA	1200	100
23697	6"	PSA	1500	100
23968	6"	PSA	2000	100

6"

SHARK ABRASIVE METAL SUPPLY CABINET

ITEM# 16990

Installers Most-Used Abrasives, Cut-Off Wheels, and Accessories.

Includes:

- 3/8" Mandrel - 1
- 2" Twist Lock Holder - 1
- 3" Twist Lock Holder - 1
- Cut-Off Wheels 3"x1/32"x3/8" 54 Grit - 10
- Cut-Off Wheels 3"x1/16"x3/8" 54 Grit - 10
- 2" Green Mini Grinding Discs 50 Grit - 10
- 3" Green Mini Grinding Discs 50 Grit - 10
- 2" Surface Prep Discs Medium (Red) - 25
- 3" Surface Prep Discs Medium (Red) - 10
- 2" Surface Prep Discs Coarse (Brown) - 25
- 3" Surface Prep Discs Coarse (Brown) - 10
- Shark Commercial Cabinet 19"x4"x26" - 1



SHARK ABRASIVE ASSORTMENT DISPLAY

Applications:

This 244 piece kit is ideal for cutting or sanding various metals. Our USA made cut-off wheels are reinforced with fiberglass for increased durability. This kit includes two of our most popular wheels made in the USA.

Our long lasting, aggressive zirconia discs are for heavy stock removal. Finer grits are used when blending and finishing metals. Ideal for deburring, oxidation, fire scale removal, cleaning, blending or smoothing. All our surface prep discs come with the Twist-to-Lock backing for secure and easy attachment.



16403

ITEM# **16403**

KIT INCLUDES:

Tools: Angle grinders or die grinders

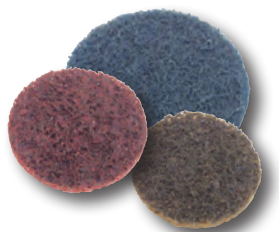

Star-Brite Surface Conditioning Discs:

- 13062 ■ 2" Brown, Coarse Grit - 10 each
- 13018 ■ 2" Burgundy, Medium Grit - 8 each
- 624TB ■ 2" Blue, Fine Grit - 8 each

- 13019 ■ 3" Brown, Coarse Grit - 10 each
- 13020 ■ 3" Burgundy, Medium Grit - 8 each
- 634TB ■ 3" Blue, Fine Grit - 8 each

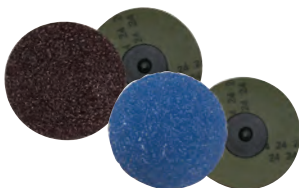
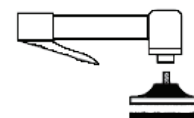
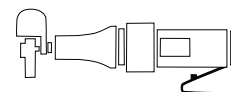

Aluminum Oxide & Zirconia Mini Grinding Discs:

- 13226 ■ 2" Aluminum Oxide 24 Grit - 10 each
- 13228 ■ 2" Aluminum Oxide 50 Grit - 8 each
- 13235 ■ 3" Aluminum Oxide 36 Grit - 10 each
- 13236 ■ 3" Aluminum Oxide 50 Grit - 8 each

- 13243 ■ 2" Zirconia 36 Grit - 8 each
- 13251 ■ 3" Zirconia 36 Grit - 8 each



Aluminide Oxide Resin Bonded Cut-Off Wheels:

- 12704 ■ 3" x 1/16" x 3/8" 54 Grit - 60 each
- 12700 ■ 3" x 1/32" x 3/8" 54 Grit - 60 each

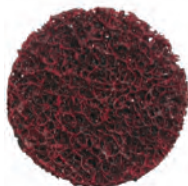

Strip-Brite Pads:

- 16202 ■ 2" Red Stripper Pad with Twist-To-Lock Backing Pad - 6 each
- 16203 ■ 3" Red Stripper Pad with Twist-To-Lock Backing Pad - 3 each



Surface Prep Twist-To-Lock Holders:

- 13012 ■ 2" Twist-To-Lock Backing Pad - 6 each
- 13013 ■ 3" Twist-To-Lock Backing Pad - 4 each



UNITIZED WHEELS

Designed to offer the best finish combined with high tear resistance and long life, Unitized Wheels are produced by compressing several layers of Abrasive Non Woven material impregnated with resin.

Aluminum Oxide for use on all ferrous metals/ steel and Stainless Steel.

Silicon Carbide for use on non-ferrous metals / alloys, copper, aluminum, and brass.



Benefits

Long Lasting - The incredible resistance working on sharp edges gives maximum productivity

Best Finishing - A consistent and uniform finishing, close to mirror finishing surface can be reached without smearing in one step operation, saving time and additional steps. Improve surfaces without significantly changing the shape or dimension of the work piece.

No Loading, Low Temperature - The Non Woven structure gives high resistance to loading and minimizes heat buildup. Flexible and Conforming - Depending on the density, the user can have a soft and flexible material, with high conformability or tough aggressive action. In all densities, Unitized Wheels can be dressed to follow the shape of the worked piece and work in narrow areas.

Low Noise - The soft structure reduces the noise level during the application.

Twist-to-lock Style Holder - Universal Type "R" button works with any brand holder.

Applications

Soft Density

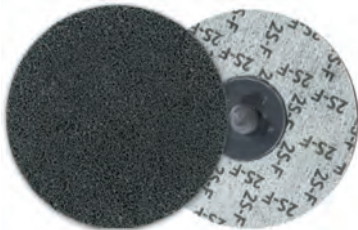

Maximum resistance to loading soft density gives the best finishing with an easy to control cut action.

Best For:

- Polishing mechanical parts (jet blades, threads, casted parts, welds, surgical instruments)
- Cleaning loading materials (rust, discolorations, resin, coating)
- Blending marks or scratches

Medium Density

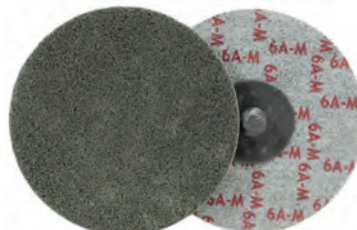

High edge durability and faster cutting action.

Best For:

- Removing burrs (on stainless steel parts, gears) or reducing edges
- Blending marks or scratches
- Cleaning heavy scale or oxidations

Hard Density

Available in coarse grit to allow high pressure for fast cutting action and longevity on heavy applications.

Best For:

- Removing heavy burrs or reducing sharp edges
- Blending heavy marks or scratches
- Faster cleaning on heavy scale or oxidations

The characteristics of each disc are identified by a 3-digit code.



Density			
S	M/S	M	H
Soft	Medium/Soft	Medium	Hard

Type of Abrasive Grain	
A	S
Aluminum Oxide	Silicon Carbide

Grit		
F	M	C
Fine	Medium	Coarse

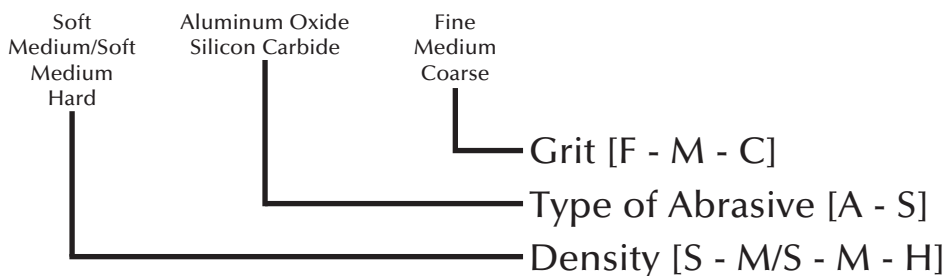

2" DIAMETER UNITIZED WHEELS

Item#	Code	Density	Type	Grit	Thickness	Pkg. Qty.
13160	SSF	Soft	Silicon Carbide	Fine	1/4"	3
13161	SAM	Soft	Aluminum Oxide	Medium	1/4"	3
13162	M/SSF	Medium/Soft	Silicon Carbide	Fine	1/4"	3
13163	MSF	Medium	Silicon Carbide	Fine	1/4"	3
13164	MAM	Medium	Aluminum Oxide	Medium	1/4"	3
13165	HAC	Hard	Aluminum Oxide	Coarse	1/4"	3



3" DIAMETER UNITIZED WHEELS

Item#	Code	Density	Type	Grit	Thickness	Pkg. Qty.
13166	SSF	Soft	Silicon Carbide	Fine	1/4"	3
13167	SAM	Soft	Aluminum Oxide	Medium	1/4"	3
13168	M/SSF	Medium/Soft	Silicon Carbide	Fine	1/4"	3
13169	MSF	Medium	Silicon Carbide	Fine	1/4"	3
13170	MAM	Medium	Aluminum Oxide	Medium	1/4"	3
13171	HAC	Hard	Aluminum Oxide	Coarse	1/4"	3

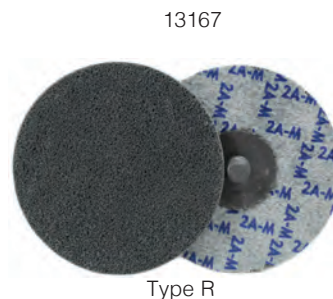

4 1/2" DIAMETER DEPRESSED CENTER UNITIZED WHEELS

Item#	Code	Density	Type	Grit	Thickness	Pkg. Qty.
13172	SSF	Soft	Silicon Carbide	Fine	1/2"	1
13173	SAM	Soft	Aluminum Oxide	Medium	1/2"	1
13174	M/SSF	Medium/Soft	Silicon Carbide	Fine	1/2"	1
13175	MSF	Medium	Silicon Carbide	Fine	1/2"	1
13176	MAM	Medium	Aluminum Oxide	Medium	1/2"	1
13177	HAC	Hard	Aluminum Oxide	Coarse	1/2"	1

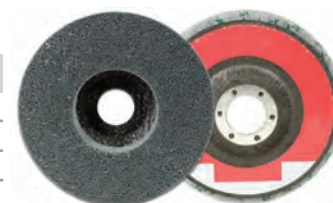



ZIRCONIA MINI BELTS FOR BELT SANDERS A MUST FOR FORD F-150 WORK

3/8" x 13" and 1/2" x 18"

- Seam Seal Removal
- Self Piercing Rivet Sanding
- Surface Prep in Rivet-bonded Repairs



These belts are designed to be used on any Mini Belt Sander of either 3/8" x 13" or 1/2" x 18" size. The Zirconia belts are perfect for aluminum sanding of self-piercing rivets, as well as seam seal removal and preparing surfaces in the cases of rivet-bonded material repairs on the new Ford F-150 Trucks. The belts will work with any manufacturer's tool using the above mentioned sizes.

- Durable Poly/Cotton Backing
- Long Life Zirconia will outlast Aluminum Oxide
- Performs better on Aluminum than Aluminum Oxide

3/8" x 13" Length Belts

Part#	Grit	Material	Pkg. Qty.
13182	40	Zirconia	10
13183	60	Zirconia	10
13184	80	Zirconia	10
13185	120	Zirconia	10

1/2" x 18" Length Belts

Part#	Grit	Material	Pkg. Qty.
13186	40	Zirconia	10
13187	60	Zirconia	10
13188	80	Zirconia	10
13189	120	Zirconia	10





SHARK INDUSTRIES

Flap Discs

- ▶ Plastic Backed Flap Discs
- ▶ Ceramic Flap Discs
- ▶ Aluminum Oxide Flap Discs
- ▶ Zirconia Cartridge Rolls
- ▶ Zirconia Flap Discs
- ▶ Mini Flap Discs
 - ▶ Type 27
 - ▶ Type 29
 - ▶ Cup Style

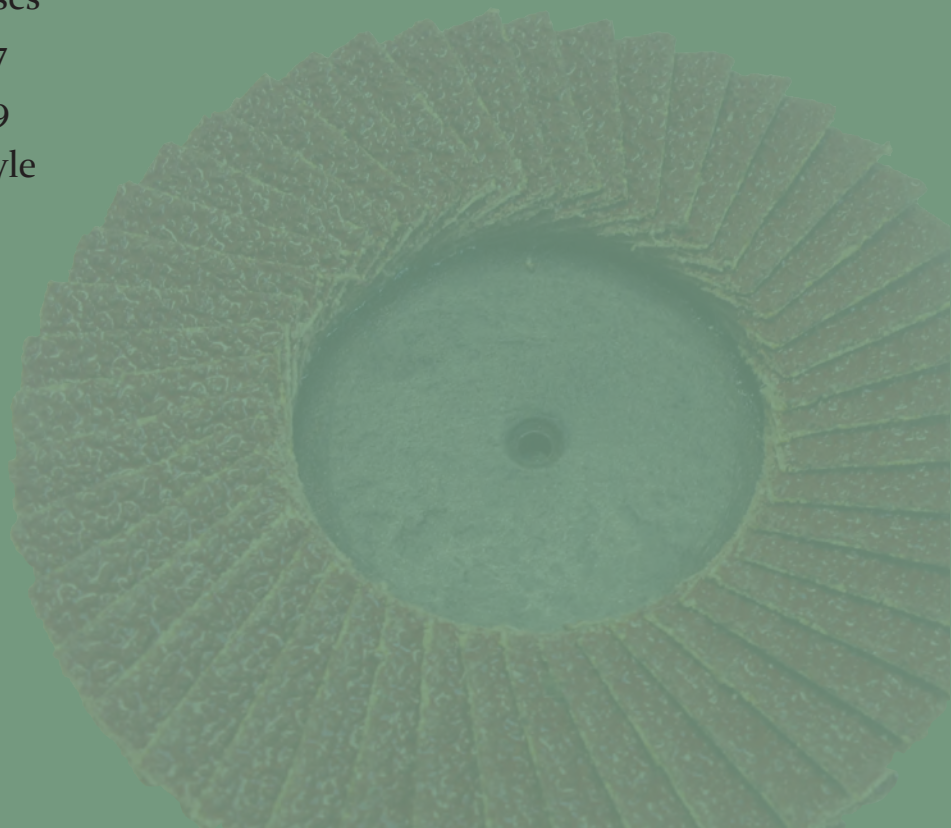



ABRASIVE FLAP DISCS

Flap discs use diagonal layers of sandpaper on resin fiber backing. Flaps are glued onto multi-layer fiber-glass, plastic or aluminum backing plates. As the flaps wear down, new grit is continuously being exposed for

consistent performance throughout the life of the disc. Flap discs are designed to run cooler, thereby reducing warping of thin metals such as body panels. Unlike ordinary grinding wheels, these discs won't gouge your work.

FLAP DISC SHAPES

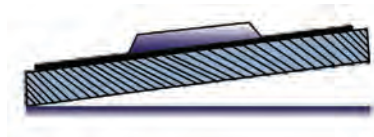

TYPE 27 FLAT

- Used primarily on flat surfaces
- The best choice for blending and smooth finishing



TYPE 29 BEVELED

- Conical flap discs are angled and may be used on both contoured and edge work
- The angle provides greater surface contact for stock removal on flat surfaces
- The best choice when speed and stock removal are primary considerations

FLAP DISC TYPES

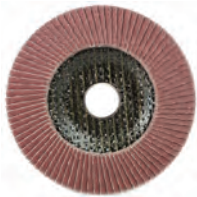

ALUMINUM OXIDE FLAP DISCS

Features: The original metalworking abrasive grain, this product is recommended for many jobs where a consistent, low cost product is needed. For steel applications.



ZIRCONIA FLAP DISCS

Features: Zirconia provides a very good cut rate to cost ratio. This is a long life grain and works well on stainless steel applications; providing longer life than Aluminum Oxide.

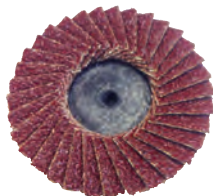

TYPE 27 MINI FLAP DISCS

Features: Mini Flap discs provide all the same benefits of regular flap discs and work great in tight areas, for hard to reach spots, making it easier to maneuver.



HIGH DENSITY JUMBO DISCS

Features: High Density Zirconia flap discs offer an increased number of flaps with larger flap sizes compared to standard discs. Especially suitable for industrial applications.



MINI CUP FLAP DISCS

Features: Mini cup flap discs are suited for contoured surfaces. More flexible and conformable compared to mini grinding discs or Type 27 Mini Flap discs.

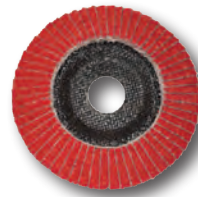

CERAMIC FLAP DISCS

Features: Tough, durable, long life grain, with very fine crystal structure to create many more cutting edges in each grain. Used for highest rate of stock removal in hard metals or stainless steel.



ZIRCONIA PLASTIC BACKED FLAP DISCS

Features: These high performance plastic backed Zirconia discs are made for one-step operation on a variety of materials, from grinding welds to detailed finishing.

APPLICATION/GRIT RECOMMENDATION GUIDE

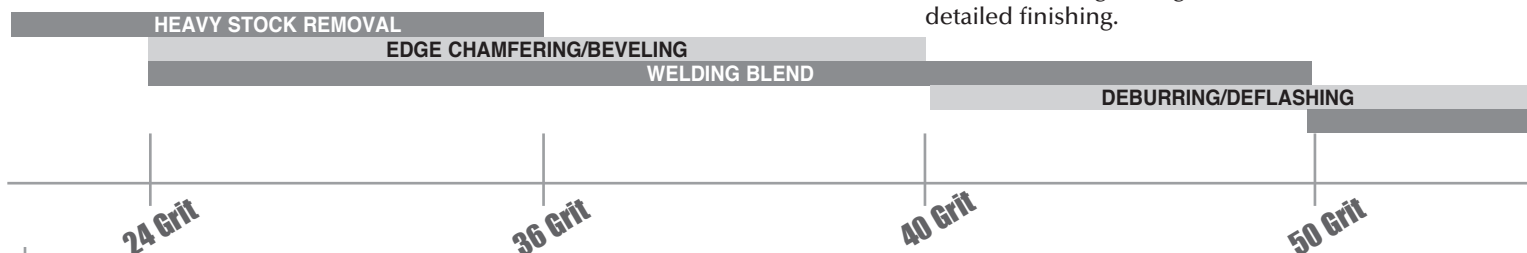

ZIRCONIA PLASTIC BACKED FLAP DISCS

These **plastic-backed flap discs** are a replacement for sanding discs and enable a one-step operation. From grinding welds to detailed blending and finishing, the improved plastic backing plate evenly wears down with the abrasive flaps while new surfaces are exposed, maintaining a uniform cutting action.



Applications:

Ferrous and non-ferrous materials, stainless steel, high tensile steels, aluminum, structural steel, cast iron, plastic, fiberglass, and brass.

TYPE 27 FLAP DISCS

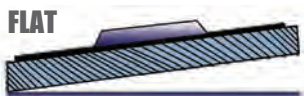

Item#	Size	Arbor	Grit	Grain
47000	4.5"	7/8"	36	Zirconia
47001	4.5"	7/8"	40	Zirconia
47002	4.5"	7/8"	60	Zirconia
47003	4.5"	7/8"	80	Zirconia
47004	4.5"	7/8"	120	Zirconia
47005	4.5"	5/8"-11	36	Zirconia
47006	4.5"	5/8"-11	40	Zirconia
47007	4.5"	5/8"-11	60	Zirconia
47008	4.5"	5/8"-11	80	Zirconia
47009	4.5"	5/8"-11	120	Zirconia

TYPE 29 FLAP DISCS



Item#	Size	Arbor	Grit	Grain
47010	4.5"	7/8"	36	Zirconia
47011	4.5"	7/8"	40	Zirconia
47012	4.5"	7/8"	60	Zirconia
47013	4.5"	7/8"	80	Zirconia
47014	4.5"	7/8"	120	Zirconia
47015	4.5"	5/8"-11	36	Zirconia
47016	4.5"	5/8"-11	40	Zirconia
47017	4.5"	5/8"-11	60	Zirconia
47018	4.5"	5/8"-11	80	Zirconia
47019	4.5"	5/8"-11	120	Zirconia

RUST REMOVAL/BLENDING

CLEANING AND FINISHING

60 Grit

80 Grit

100 Grit

120 Grit



ABRASIVE FLAP DISCS

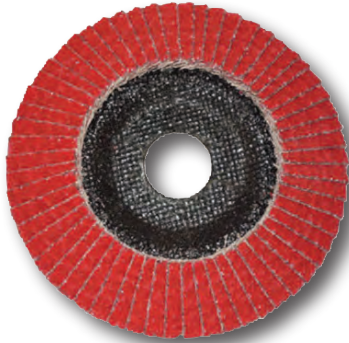

CERAMIC

- Longest life grain
- For use on flat or curved surfaces
- Aggressive shape disc

Premium Ceramic Grain has Extended Life over Zirconia. Our Premium Ceramic discs are designed for use on Stainless Steel or other very hard steels. This tough, durable grain with very fine crystal structure creates many more cutting edges per grain.

TYPE 27

Item#	Size	Arbor	Grit	Style	Grain	Shape	Pk. Qty	MP
46180	4 1/2"	7/8"	36	Standard	Ceramic	Type 27	1	5
46181	4 1/2"	7/8"	36	Standard	Ceramic	Type 27	10	2
46182	4 1/2"	7/8"	40	Standard	Ceramic	Type 27	1	5
46183	4 1/2"	7/8"	40	Standard	Ceramic	Type 27	10	2
46184	4 1/2"	7/8"	60	Standard	Ceramic	Type 27	1	5
46185	4 1/2"	7/8"	60	Standard	Ceramic	Type 27	10	2
46186	4 1/2"	7/8"	80	Standard	Ceramic	Type 27	1	5
46187	4 1/2"	7/8"	80	Standard	Ceramic	Type 27	10	2
46188	4 1/2"	7/8"	120	Standard	Ceramic	Type 27	1	5
46189	4 1/2"	7/8"	120	Standard	Ceramic	Type 27	10	2

TYPE 29

Item#	Size	Arbor	Grit	Style	Grain	Shape	Pk. Qty	MP
46190	4 1/2"	7/8"	36	Standard	Ceramic	Type 29	1	5
46191	4 1/2"	7/8"	36	Standard	Ceramic	Type 29	10	2
46192	4 1/2"	7/8"	40	Standard	Ceramic	Type 29	1	5
46193	4 1/2"	7/8"	40	Standard	Ceramic	Type 29	10	2
46194	4 1/2"	7/8"	60	Standard	Ceramic	Type 29	1	5
46195	4 1/2"	7/8"	60	Standard	Ceramic	Type 29	10	2
46196	4 1/2"	7/8"	80	Standard	Ceramic	Type 29	1	5
46197	4 1/2"	7/8"	80	Standard	Ceramic	Type 29	10	2
46198	4 1/2"	7/8"	120	Standard	Ceramic	Type 29	1	5
46199	4 1/2"	7/8"	120	Standard	Ceramic	Type 29	10	2



ABRASIVE FLAP DISCS

ALUMINUM OXIDE

TYPE 27

- For use on flat or curved surfaces. Aggressive shape disc.

FLAT



Aluminum Oxide: Made of the highest grade Aluminum Oxide paper, this is the most price competitive product. It is designed to be used on steels and non-ferrous metals. Not designed for use on Stainless Steel, it will not perform or last as long as a Zirconia grain wheel.

Item#	Old#	Size	Arbor	Grit	Style	Grain	Shape	Pk. Qty	MP
45819	F436	4"	5/8"	36	Standard	Aluminum Oxide	Type 27	1	10
45820	F436-10	4"	5/8"	36	Standard	Aluminum Oxide	Type 27	10	2
45821		4"	5/8"	40	Standard	Aluminum Oxide	Type 27	1	10
45822		4"	5/8"	40	Standard	Aluminum Oxide	Type 27	10	2
45823	F460	4"	5/8"	60	Standard	Aluminum Oxide	Type 27	1	10
45824	F460-10	4"	5/8"	60	Standard	Aluminum Oxide	Type 27	10	2
45825	F480	4"	5/8"	80	Standard	Aluminum Oxide	Type 27	1	10
45826	F480-10	4"	5/8"	80	Standard	Aluminum Oxide	Type 27	10	2
45827	F4120	4"	5/8"	120	Standard	Aluminum Oxide	Type 27	1	10
45828	F4120-10	4"	5/8"	120	Standard	Aluminum Oxide	Type 27	10	2
12900	F4536	4 1/2"	7/8"	36	Standard	Aluminum Oxide	Type 27	1	10
45829	F4536-10	4 1/2"	7/8"	36	Standard	Aluminum Oxide	Type 27	10	5
45830		4 1/2"	7/8"	40	Standard	Aluminum Oxide	Type 27	1	10
45831		4 1/2"	7/8"	40	Standard	Aluminum Oxide	Type 27	10	5
12901	F4560	4 1/2"	7/8"	60	Standard	Aluminum Oxide	Type 27	1	10
45832	F4560-10	4 1/2"	7/8"	60	Standard	Aluminum Oxide	Type 27	10	5
12902	F4580	4 1/2"	7/8"	80	Standard	Aluminum Oxide	Type 27	1	10
45833	F4580-10	4 1/2"	7/8"	80	Standard	Aluminum Oxide	Type 27	10	5
45834	F45120	4 1/2"	7/8"	120	Standard	Aluminum Oxide	Type 27	1	10
45835	F45120-10	4 1/2"	7/8"	120	Standard	Aluminum Oxide	Type 27	10	5
45846		5"	7/8"	36	Standard	Aluminum Oxide	Type 27	1	10
45847		5"	7/8"	36	Standard	Aluminum Oxide	Type 27	10	5
45848		5"	7/8"	40	Standard	Aluminum Oxide	Type 27	1	10
45849		5"	7/8"	40	Standard	Aluminum Oxide	Type 27	10	5
45850		5"	7/8"	60	Standard	Aluminum Oxide	Type 27	1	10
45851		5"	7/8"	60	Standard	Aluminum Oxide	Type 27	10	5
45852		5"	7/8"	80	Standard	Aluminum Oxide	Type 27	1	10
45853		5"	7/8"	80	Standard	Aluminum Oxide	Type 27	10	5
45854		5"	7/8"	120	Standard	Aluminum Oxide	Type 27	1	10
45855		5"	7/8"	120	Standard	Aluminum Oxide	Type 27	10	5
12903	F736	7"	7/8"	36	Standard	Aluminum Oxide	Type 27	1	10
45856	F736-10	7"	7/8"	36	Standard	Aluminum Oxide	Type 27	10	5
45857		7"	7/8"	40	Standard	Aluminum Oxide	Type 27	1	10
45858		7"	7/8"	40	Standard	Aluminum Oxide	Type 27	10	5
12904	F760	7"	7/8"	60	Standard	Aluminum Oxide	Type 27	1	10
45859	F760-10	7"	7/8"	60	Standard	Aluminum Oxide	Type 27	10	5
12905	F780	7"	7/8"	80	Standard	Aluminum Oxide	Type 27	1	10
45860	F780-10	7"	7/8"	80	Standard	Aluminum Oxide	Type 27	10	5
45861	F7120	7"	7/8"	120	Standard	Aluminum Oxide	Type 27	1	10
45862	F7120-10	7"	7/8"	120	Standard	Aluminum Oxide	Type 27	10	5



ABRASIVE FLAP DISCS

TYPE 29

- For use on flat or curved surfaces
- Angle built into the disc - offers the user easier grinding action.

BEVELED



Aluminum Oxide: Made of the highest grade Aluminum Oxide paper, this grain is the most price competitive product. It is designed to be used on steels and non-ferrous metals. Not designed for use on Stainless Steel, it will not perform or last as long as a Zirconia grain wheel.

ALUMINUM OXIDE

Item#	Size	Arbor	Grit	Style	Grain	Shape	Pk. Qty	MP
45863	4"	5/8"	36	Standard	Aluminum Oxide	Type 29	1	10
45864	4"	5/8"	40	Standard	Aluminum Oxide	Type 29	1	10
45865	4"	5/8"	60	Standard	Aluminum Oxide	Type 29	1	10
45866	4"	5/8"	80	Standard	Aluminum Oxide	Type 29	1	10
45867	4"	5/8"	120	Standard	Aluminum Oxide	Type 29	1	10
45736	4 1/2"	7/8"	36	Standard	Aluminum Oxide	Type 29	1	10
45868	4 1/2"	7/8"	40	Standard	Aluminum Oxide	Type 29	1	10
45738	4 1/2"	7/8"	60	Standard	Aluminum Oxide	Type 29	1	10
45740	4 1/2"	7/8"	80	Standard	Aluminum Oxide	Type 29	1	10
45742	4 1/2"	7/8"	120	Standard	Aluminum Oxide	Type 29	1	10
45737	4 1/2"	5/8"-11	36	Standard	Aluminum Oxide	Type 29	1	5
45744	4 1/2"	5/8"-11	40	Standard	Aluminum Oxide	Type 29	1	5
45739	4 1/2"	5/8"-11	60	Standard	Aluminum Oxide	Type 29	1	5
45741	4 1/2"	5/8"-11	80	Standard	Aluminum Oxide	Type 29	1	5
45743	4 1/2"	5/8"-11	120	Standard	Aluminum Oxide	Type 29	1	5

TYPE 27

- For use on flat or curved surfaces
- Aggressive shape disc

FLAT

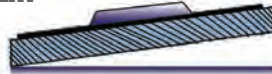

Premium Zirconia: Made of our Premium 100% Zirconia, this grain is the highest quality and designed specifically for Stainless Steel or harder metals; lasting extremely long if used on regular steel.

PREMIUM PLATINUM ZIRCONIA

Item#	Old#	Size	Arbor	Grit	Style	Grain	Shape	Pk. Qty	MP
13137	F436Z	4"	5/8"	36	Standard	100% Zirconia	Type 27	1	50
45870	F436Z-10	4"	5/8"	36	Standard	100% Zirconia	Type 27	10	10
45871		4"	5/8"	40	Standard	100% Zirconia	Type 27	1	50
45872		4"	5/8"	40	Standard	100% Zirconia	Type 27	10	10
13138	F460Z	4"	5/8"	60	Standard	100% Zirconia	Type 27	1	50
45873	F460Z-10	4"	5/8"	60	Standard	100% Zirconia	Type 27	10	10
13139	F480Z	4"	5/8"	80	Standard	100% Zirconia	Type 27	1	50
45874	F480Z-10	4"	5/8"	80	Standard	100% Zirconia	Type 27	10	10
45875	F4120Z	4"	5/8"	120	Standard	100% Zirconia	Type 27	1	50
45876	F4120Z-10	4"	5/8"	120	Standard	100% Zirconia	Type 27	10	10
13134	F4536Z	4 1/2"	7/8"	36	Standard	100% Zirconia	Type 27	1	50
45877	F4536Z-10	4 1/2"	7/8"	36	Standard	100% Zirconia	Type 27	10	10
45879		4 1/2"	7/8"	40	Standard	100% Zirconia	Type 27	1	50
45880		4 1/2"	7/8"	40	Standard	100% Zirconia	Type 27	10	10
13135	F4560Z	4 1/2"	7/8"	60	Standard	100% Zirconia	Type 27	1	50
45881	F4560Z-10	4 1/2"	7/8"	60	Standard	100% Zirconia	Type 27	10	10
13136	F4580Z	4 1/2"	7/8"	80	Standard	100% Zirconia	Type 27	1	10
45882	F4580Z-10	4 1/2"	7/8"	80	Standard	100% Zirconia	Type 27	10	10
45883	F45120Z	4 1/2"	7/8"	120	Standard	100% Zirconia	Type 27	1	50
45884	F45120Z-10	4 1/2"	7/8"	120	Standard	100% Zirconia	Type 27	10	10

ABRASIVE FLAP DISCS

PREMIUM PLATINUM ZIRCONIA

TYPE 27

- For use on flat or curved surfaces
- Aggressive shape disc

FLAT



Premium Zirconia: Made of our Premium 100% Zirconia, this grain is the highest quality and designed specifically for Stainless Steel or harder metals; lasting extremely long if used on regular steel.

Item#	Old#	Size	Arbor	Grit	Style	Grain	Shape	Pk. Qty	MP
12906	F4536ZH	4 1/2"	5/8"-11	36	Standard	100% Zirconia	Type 27	1	10
45869		4 1/2"	5/8"-11	40	Standard	100% Zirconia	Type 27	1	10
12907	F4560ZH	4 1/2"	5/8"-11	60	Standard	100% Zirconia	Type 27	1	10
12908	F4580ZH	4 1/2"	5/8"-11	80	Standard	100% Zirconia	Type 27	1	10
45878	F45120ZH	4 1/2"	5/8"-11	120	Standard	100% Zirconia	Type 27	1	10
45885		5"	7/8"	36	Standard	100% Zirconia	Type 27	1	10
45886		5"	7/8"	36	Standard	100% Zirconia	Type 27	10	5
45887		5"	7/8"	40	Standard	100% Zirconia	Type 27	1	5
45888		5"	7/8"	40	Standard	100% Zirconia	Type 27	10	5
45889		5"	7/8"	60	Standard	100% Zirconia	Type 27	1	10
45890		5"	7/8"	60	Standard	100% Zirconia	Type 27	10	5
45891		5"	7/8"	80	Standard	100% Zirconia	Type 27	1	10
45892		5"	7/8"	80	Standard	100% Zirconia	Type 27	10	5
45893		5"	7/8"	120	Standard	100% Zirconia	Type 27	1	10
45894		5"	7/8"	120	Standard	100% Zirconia	Type 27	10	5
13140	F736Z	7"	7/8"	36	Standard	100% Zirconia	Type 27	1	10
45895	F736Z-10	7"	7/8"	36	Standard	100% Zirconia	Type 27	10	5
45896		7"	7/8"	40	Standard	100% Zirconia	Type 27	1	10
45897		7"	7/8"	40	Standard	100% Zirconia	Type 27	10	4
13141	F760Z	7"	7/8"	60	Standard	100% Zirconia	Type 27	1	10
45898	F760Z-10	7"	7/8"	60	Standard	100% Zirconia	Type 27	10	4
13148	F780Z	7"	7/8"	80	Standard	100% Zirconia	Type 27	1	10
45899	F780Z-10	7"	7/8"	80	Standard	100% Zirconia	Type 27	10	4
45900	F7120Z	7"	7/8"	120	Standard	100% Zirconia	Type 27	1	10
45901	F7120Z-10	7"	7/8"	120	Standard	100% Zirconia	Type 27	10	4
12909	F736ZH	7"	5/8"-11	36	Standard	100% Zirconia	Type 27	1	10
12958		7"	5/8"-11	40	Standard	100% Zirconia	Type 27	1	10
12910	F760ZH	7"	5/8"-11	60	Standard	100% Zirconia	Type 27	1	10
12911	F780ZH	7"	5/8"-11	80	Standard	100% Zirconia	Type 27	1	10
45902	F7120ZH	7"	5/8"-11	120	Standard	100% Zirconia	Type 27	1	10



13135



ABRASIVE FLAP DISCS

PREMIUM PLATINUM ZIRCONIA

TYPE 29

- For use on flat or curved surfaces
- Angle built into the disc - offers the user easier grinding action.

BEVELED



Premium Zirconia: Made of our Premium 100% Zirconia, this grain is the highest quality and designed specifically for Stainless Steel or harder metals; lasting extremely long if used on regular steel.

Item#	Size	Arbor	Grit	Style	Grain	Shape	Pk. Qty	MP
45903	4"	5/8"	36	Standard	100% Zirconia	Type 29	1	10
45904	4"	5/8"	40	Standard	100% Zirconia	Type 29	1	10
45905	4"	5/8"	60	Standard	100% Zirconia	Type 29	1	10
45906	4"	5/8"	80	Standard	100% Zirconia	Type 29	1	10
45907	4"	5/8"	120	Standard	100% Zirconia	Type 29	1	10
45836	4 1/2"	7/8"	36	Standard	100% Zirconia	Type 29	1	10
45908	4 1/2"	7/8"	36	Standard	100% Zirconia	Type 29	10	5
45909	4 1/2"	7/8"	40	Standard	100% Zirconia	Type 29	1	10
45910	4 1/2"	7/8"	40	Standard	100% Zirconia	Type 29	10	5
45838	4 1/2"	7/8"	60	Standard	100% Zirconia	Type 29	1	10
45912	4 1/2"	7/8"	60	Standard	100% Zirconia	Type 29	10	5
45840	4 1/2"	7/8"	80	Standard	100% Zirconia	Type 29	1	10
45913	4 1/2"	7/8"	80	Standard	100% Zirconia	Type 29	10	5
45842	4 1/2"	7/8"	120	Standard	100% Zirconia	Type 29	1	10
45914	4 1/2"	7/8"	120	Standard	100% Zirconia	Type 29	10	5
45837	4 1/2"	5/8"-11	36	Standard	100% Zirconia	Type 29	1	10
45915	4 1/2"	5/8"-11	40	Standard	100% Zirconia	Type 29	1	10
45839	4 1/2"	5/8"-11	60	Standard	100% Zirconia	Type 29	1	10
45841	4 1/2"	5/8"-11	80	Standard	100% Zirconia	Type 29	1	10
45843	4 1/2"	5/8"-11	120	Standard	100% Zirconia	Type 29	1	10
45916	5"	7/8"	36	Standard	100% Zirconia	Type 29	1	10
45917	5"	7/8"	36	Standard	100% Zirconia	Type 29	10	5
45918	5"	7/8"	40	Standard	100% Zirconia	Type 29	1	10
45919	5"	7/8"	40	Standard	100% Zirconia	Type 29	10	5
45920	5"	7/8"	60	Standard	100% Zirconia	Type 29	1	10
45921	5"	7/8"	60	Standard	100% Zirconia	Type 29	10	5
45922	5"	7/8"	80	Standard	100% Zirconia	Type 29	1	10
45923	5"	7/8"	80	Standard	100% Zirconia	Type 29	10	5
45924	5"	7/8"	120	Standard	100% Zirconia	Type 29	1	10
45925	5"	7/8"	120	Standard	100% Zirconia	Type 29	10	5
45926	7"	7/8"	36	Standard	100% Zirconia	Type 29	1	10
45927	7"	7/8"	36	Standard	100% Zirconia	Type 29	10	2
45928	7"	7/8"	40	Standard	100% Zirconia	Type 29	1	10
45929	7"	7/8"	40	Standard	100% Zirconia	Type 29	1	10
45930	7"	7/8"	60	Standard	100% Zirconia	Type 29	1	10
45931	7"	7/8"	80	Standard	100% Zirconia	Type 29	1	10
45932	7"	7/8"	120	Standard	100% Zirconia	Type 29	1	10
45933	7"	7/8"	120	Standard	100% Zirconia	Type 29	10	2

ABRASIVE FLAP DISCS

PREMIUM ECONOMY ZIRCONIA ECONOMY GRADE 100%

TYPE 27

- For use on flat or curved surfaces
- Aggressive shape disc

FLAT

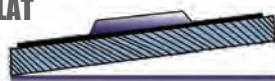

Premium Economy Zirconia: Made of our second grade 100% Zirconia, this grain is excellent quality at a more affordable price point. It is designed specifically for Stainless Steel or harder metals; and will last extremely long when used on regular steel.

Item#	Size	Arbor	Grit	Style	Grain	Shape	Pk. Qty	MP
45934	4"	5/8"	36	Standard	100% Econ Zirconia	Type 27	1	5
45935	4"	5/8"	36	Standard	100% Econ Zirconia	Type 27	10	2
45936	4"	5/8"	40	Standard	100% Econ Zirconia	Type 27	1	5
45937	4"	5/8"	40	Standard	100% Econ Zirconia	Type 27	10	2
45938	4"	5/8"	60	Standard	100% Econ Zirconia	Type 27	1	5
45939	4"	5/8"	60	Standard	100% Econ Zirconia	Type 27	10	2
45940	4"	5/8"	80	Standard	100% Econ Zirconia	Type 27	1	5
45941	4"	5/8"	80	Standard	100% Econ Zirconia	Type 27	10	2
45942	4"	5/8"	120	Standard	100% Econ Zirconia	Type 27	1	5
45943	4"	5/8"	120	Standard	100% Econ Zirconia	Type 27	10	2
45944	4 1/2"	7/8"	36	Standard	100% Econ Zirconia	Type 27	1	10
45945	4 1/2"	7/8"	36	Standard	100% Econ Zirconia	Type 27	10	5
45946	4 1/2"	7/8"	40	Standard	100% Econ Zirconia	Type 27	1	10
45947	4 1/2"	7/8"	40	Standard	100% Econ Zirconia	Type 27	10	5
45948	4 1/2"	7/8"	60	Standard	100% Econ Zirconia	Type 27	1	10
45949	4 1/2"	7/8"	60	Standard	100% Econ Zirconia	Type 27	10	5
45950	4 1/2"	7/8"	80	Standard	100% Econ Zirconia	Type 27	1	10
45951	4 1/2"	7/8"	80	Standard	100% Econ Zirconia	Type 27	10	5
45952	4 1/2"	7/8"	120	Standard	100% Econ Zirconia	Type 27	1	10
45953	4 1/2"	7/8"	120	Standard	100% Econ Zirconia	Type 27	10	5
45954	4 1/2"	5/8"-11	36	Standard	100% Econ Zirconia	Type 27	1	5
45955	4 1/2"	5/8"-11	40	Standard	100% Econ Zirconia	Type 27	1	5
45956	4 1/2"	5/8"-11	60	Standard	100% Econ Zirconia	Type 27	1	5
45957	4 1/2"	5/8"-11	80	Standard	100% Econ Zirconia	Type 27	1	5
45958	4 1/2"	5/8"-11	120	Standard	100% Econ Zirconia	Type 27	1	5
45959	5"	7/8"	36	Standard	100% Econ Zirconia	Type 27	1	10
45960	5"	7/8"	36	Standard	100% Econ Zirconia	Type 27	10	5
45961	5"	7/8"	40	Standard	100% Econ Zirconia	Type 27	1	10
45962	5"	7/8"	40	Standard	100% Econ Zirconia	Type 27	10	5
45963	5"	7/8"	60	Standard	100% Econ Zirconia	Type 27	1	10
45964	5"	7/8"	60	Standard	100% Econ Zirconia	Type 27	10	5
45965	5"	7/8"	80	Standard	100% Econ Zirconia	Type 27	1	10
45966	5"	7/8"	80	Standard	100% Econ Zirconia	Type 27	10	5
45967	5"	7/8"	120	Standard	100% Econ Zirconia	Type 27	1	10
45968	5"	7/8"	120	Standard	100% Econ Zirconia	Type 27	10	5
45969	5"	5/8"-11	36	Standard	100% Econ Zirconia	Type 27	1	10
45970	5"	5/8"-11	40	Standard	100% Econ Zirconia	Type 27	1	10
45971	5"	5/8"-11	60	Standard	100% Econ Zirconia	Type 27	1	10
45972	5"	5/8"-11	80	Standard	100% Econ Zirconia	Type 27	1	10
45973	5"	5/8"-11	120	Standard	100% Econ Zirconia	Type 27	1	10
45974	7"	7/8"	36	Standard	100% Econ Zirconia	Type 27	10	5
45975	7"	7/8"	40	Standard	100% Econ Zirconia	Type 27	1	10
45976	7"	7/8"	40	Standard	100% Econ Zirconia	Type 27	1	5
45977	7"	7/8"	60	Standard	100% Econ Zirconia	Type 27	1	10
45978	7"	7/8"	80	Standard	100% Econ Zirconia	Type 27	1	10
45979	7"	7/8"	120	Standard	100% Econ Zirconia	Type 27	1	10
45980	7"	7/8"	120	Standard	100% Econ Zirconia	Type 27	10	5



ABRASIVE FLAP DISCS

PREMIUM ECONOMY ZIRCONIA ECONOMY GRADE 100% ZIRCONIA

TYPE 29

- For use on flat or curved surfaces
- Angle built into the disc - offers the user easier grinding action.

BEVELED

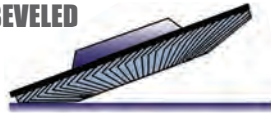

Premium Economy 100% Zirconia: Made of our second grade 100% Zirconia, this grain is excellent quality at a more affordable price point. It is designed specifically for Stainless Steel or harder metals; and will last extremely long when used on regular steel.

Item#	Size	Arbor	Grit	Style	Grain	Shape	Pk. Qty	MP
45981	4"	5/8"	36	Standard	100% Econ Zirconia	Type 29	1	10
45982	4"	5/8"	36	Standard	100% Econ Zirconia	Type 29	10	5
45983	4"	5/8"	40	Standard	100% Econ Zirconia	Type 29	1	10
45984	4"	5/8"	40	Standard	100% Econ Zirconia	Type 29	10	5
45985	4"	5/8"	60	Standard	100% Econ Zirconia	Type 29	1	10
45986	4"	5/8"	60	Standard	100% Econ Zirconia	Type 29	10	5
45987	4"	5/8"	80	Standard	100% Econ Zirconia	Type 29	1	10
45988	4"	5/8"	80	Standard	100% Econ Zirconia	Type 29	10	5
45989	4"	5/8"	120	Standard	100% Econ Zirconia	Type 29	1	10
45990	4"	5/8"	120	Standard	100% Econ Zirconia	Type 29	10	5
45991	4 1/2"	7/8"	36	Standard	100% Econ Zirconia	Type 29	1	10
45992	4 1/2"	7/8"	36	Standard	100% Econ Zirconia	Type 29	10	5
45993	4 1/2"	7/8"	40	Standard	100% Econ Zirconia	Type 29	1	10
45994	4 1/2"	7/8"	40	Standard	100% Econ Zirconia	Type 29	10	5
45995	4 1/2"	7/8"	60	Standard	100% Econ Zirconia	Type 29	1	10
45996	4 1/2"	7/8"	60	Standard	100% Econ Zirconia	Type 29	10	5
45997	4 1/2"	7/8"	80	Standard	100% Econ Zirconia	Type 29	1	10
45998	4 1/2"	7/8"	80	Standard	100% Econ Zirconia	Type 29	10	5
45999	4 1/2"	7/8"	120	Standard	100% Econ Zirconia	Type 29	1	10
46000	4 1/2"	7/8"	120	Standard	100% Econ Zirconia	Type 29	10	5
46001	4 1/2"	5/8"-11	36	Standard	100% Econ Zirconia	Type 29	1	10
46002	4 1/2"	5/8"-11	40	Standard	100% Econ Zirconia	Type 29	1	10
46003	4 1/2"	5/8"-11	60	Standard	100% Econ Zirconia	Type 29	1	10
46004	4 1/2"	5/8"-11	80	Standard	100% Econ Zirconia	Type 29	1	10
46005	4 1/2"	5/8"-11	120	Standard	100% Econ Zirconia	Type 29	1	10
46006	5"	7/8"	36	Standard	100% Econ Zirconia	Type 29	1	10
46007	5"	7/8"	36	Standard	100% Econ Zirconia	Type 29	10	5
46008	5"	7/8"	40	Standard	100% Econ Zirconia	Type 29	1	10
46009	5"	7/8"	40	Standard	100% Econ Zirconia	Type 29	10	5
46010	5"	7/8"	60	Standard	100% Econ Zirconia	Type 29	1	10
46011	5"	7/8"	60	Standard	100% Econ Zirconia	Type 29	10	5
46012	5"	7/8"	80	Standard	100% Econ Zirconia	Type 29	1	10
46013	5"	7/8"	80	Standard	100% Econ Zirconia	Type 29	10	5
46014	5"	7/8"	120	Standard	100% Econ Zirconia	Type 29	1	10
46015	5"	7/8"	120	Standard	100% Econ Zirconia	Type 29	10	5
46016	7"	7/8"	36	Standard	100% Econ Zirconia	Type 29	10	5
46017	7"	7/8"	40	Standard	100% Econ Zirconia	Type 29	1	10
46018	7"	7/8"	40	Standard	100% Econ Zirconia	Type 29	10	5
46019	7"	7/8"	60	Standard	100% Econ Zirconia	Type 29	1	10
46020	7"	7/8"	80	Standard	100% Econ Zirconia	Type 29	1	10
46021	7"	7/8"	120	Standard	100% Econ Zirconia	Type 29	1	10
46022	7"	7/8"	120	Standard	100% Econ Zirconia	Type 29	10	5

ABRASIVE FLAP DISCS

ECONOMY ZIRCONIA ECONOMY GRADE 60% ZIRCONIA

TYPE 27

- For use on flat or curved surfaces
- Aggressive shape disc

FLAT

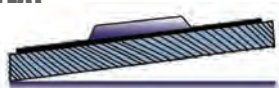

Economy 60% Zirconia: This grain is very high quality at our most affordable price point. It is designed specifically for Stainless Steel or harder metals; and will last very long when used on regular steel.

Item#	Size	Arbor	Grit	Style	Grain	Shape	Pk. Qty	MP
46023	4"	5/8"	36	Standard	60% Econ Zirconia	Type 27	1	10
46024	4"	5/8"	36	Standard	60% Econ Zirconia	Type 27	10	5
46025	4"	5/8"	40	Standard	60% Econ Zirconia	Type 27	1	10
46026	4"	5/8"	40	Standard	60% Econ Zirconia	Type 27	10	5
46027	4"	5/8"	60	Standard	60% Econ Zirconia	Type 27	1	10
46028	4"	5/8"	60	Standard	60% Econ Zirconia	Type 27	10	5
46029	4"	5/8"	80	Standard	60% Econ Zirconia	Type 27	1	10
46030	4"	5/8"	80	Standard	60% Econ Zirconia	Type 27	10	5
46031	4 1/2"	7/8"	36	Standard	60% Econ Zirconia	Type 27	1	10
46032	4 1/2"	7/8"	36	Standard	60% Econ Zirconia	Type 27	10	5
46033	4 1/2"	7/8"	40	Standard	60% Econ Zirconia	Type 27	1	10
46034	4 1/2"	7/8"	40	Standard	60% Econ Zirconia	Type 27	10	5
46035	4 1/2"	7/8"	60	Standard	60% Econ Zirconia	Type 27	1	10
46036	4 1/2"	7/8"	60	Standard	60% Econ Zirconia	Type 27	10	5
46037	4 1/2"	7/8"	80	Standard	60% Econ Zirconia	Type 27	1	10
46038	4 1/2"	7/8"	80	Standard	60% Econ Zirconia	Type 27	10	5
46039	4 1/2"	5/8"-11	36	Standard	60% Econ Zirconia	Type 27	1	10
46040	4 1/2"	5/8"-11	40	Standard	60% Econ Zirconia	Type 27	1	10
46041	4 1/2"	5/8"-11	60	Standard	60% Econ Zirconia	Type 27	1	10
46042	4 1/2"	5/8"-11	80	Standard	60% Econ Zirconia	Type 27	1	10
46043	5"	7/8"	36	Standard	60% Econ Zirconia	Type 27	1	10
46044	5"	7/8"	36	Standard	60% Econ Zirconia	Type 27	10	5
46045	5"	7/8"	40	Standard	60% Econ Zirconia	Type 27	1	10
46046	5"	7/8"	40	Standard	60% Econ Zirconia	Type 27	10	5
46047	5"	7/8"	60	Standard	60% Econ Zirconia	Type 27	1	10
46048	5"	7/8"	60	Standard	60% Econ Zirconia	Type 27	10	5
46049	5"	7/8"	80	Standard	60% Econ Zirconia	Type 27	1	10
46050	5"	7/8"	80	Standard	60% Econ Zirconia	Type 27	10	5
46051	7"	7/8"	36	Standard	60% Econ Zirconia	Type 27	1	10
46052	7"	7/8"	40	Standard	60% Econ Zirconia	Type 27	1	10
46053	7"	7/8"	60	Standard	60% Econ Zirconia	Type 27	1	10
46054	7"	7/8"	80	Standard	60% Econ Zirconia	Type 27	1	10





ABRASIVE FLAP DISCS

TYPE 29

- For use on flat or curved surfaces
- Angle built-offers the user easier grinding action

BEVELED

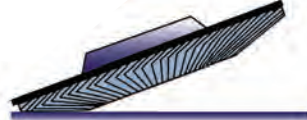

Economy 60% Zirconia: This grain is very high quality at our most affordable price point. It is designed specifically for Stainless Steel or harder metals; and will last very long when used on regular steel.

ECONOMY ZIRCONIA ECONOMY GRADE 60% ZIRCONIA

Item#	Size	Arbor	Grit	Style	Grain	Shape	Pk. Qty	MP
46059	4"	5/8"	36	Standard	60% Econ Zirconia	Type 29	1	5
46055	4"	5/8"	40	Standard	60% Econ Zirconia	Type 29	10	10
46056	4"	5/8"	60	Standard	60% Econ Zirconia	Type 29	1	10
46057	4"	5/8"	120	Standard	60% Econ Zirconia	Type 29	1	5
46058	4"	5/8"	120	Standard	60% Econ Zirconia	Type 29	10	10
46060	4 1/2"	7/8"	36	Standard	60% Econ Zirconia	Type 29	1	10
46061	4 1/2"	7/8"	36	Standard	60% Econ Zirconia	Type 29	10	5
46062	4 1/2"	7/8"	40	Standard	60% Econ Zirconia	Type 29	1	10
46063	4 1/2"	7/8"	40	Standard	60% Econ Zirconia	Type 29	10	5
46064	4 1/2"	7/8"	60	Standard	60% Econ Zirconia	Type 29	1	10
46065	4 1/2"	7/8"	60	Standard	60% Econ Zirconia	Type 29	10	5
46066	4 1/2"	7/8"	80	Standard	60% Econ Zirconia	Type 29	1	10
46067	4 1/2"	7/8"	80	Standard	60% Econ Zirconia	Type 29	10	5
46068	5"	7/8"	36	Standard	60% Econ Zirconia	Type 29	1	10
46069	5"	7/8"	36	Standard	60% Econ Zirconia	Type 29	10	5
46070	5"	7/8"	40	Standard	60% Econ Zirconia	Type 29	1	10
46071	5"	7/8"	40	Standard	60% Econ Zirconia	Type 29	10	5
46072	5"	7/8"	60	Standard	60% Econ Zirconia	Type 29	1	10
46073	5"	7/8"	60	Standard	60% Econ Zirconia	Type 29	10	5
46074	5"	7/8"	80	Standard	60% Econ Zirconia	Type 29	1	10
46075	5"	7/8"	80	Standard	60% Econ Zirconia	Type 29	10	5
46076	7"	7/8"	36	Standard	60% Econ Zirconia	Type 29	10	5
46077	7"	7/8"	40	Standard	60% Econ Zirconia	Type 29	1	10
46078	7"	7/8"	40	Standard	60% Econ Zirconia	Type 29	10	5
46079	7"	7/8"	60	Standard	60% Econ Zirconia	Type 29	10	5
46080	7"	7/8"	80	Standard	60% Econ Zirconia	Type 29	10	5



ABRASIVE FLAP DISCS

TYPE 27

- For use on flat or curved surfaces
- Aggressive shape disc
- 20% more flaps than standard discs

FLAT



Premium 100% Zirconia:

Premium High Density Zirconia discs come with more flaps per wheel and give you extremely long life products. Made of our best 100% Premium Zirconia, this grain is the highest quality grain and designed specifically for Stainless Steel or harder metals, and will last extremely long if used on regular steel.

PREMIUM PLATINUM JUMBO ZIRCONIA

Item#	Size	Arbor	Grit	Style	Grain	Shape	Pk. Qty	MP
46084	4"	5/8"	36	High-Density	100% Zirconia	Type 27	1	5
46085	4"	5/8"	40	High-Density	100% Zirconia	Type 27	1	5
46086	4"	5/8"	60	High-Density	100% Zirconia	Type 27	1	5
46087	4"	5/8"	80	High-Density	100% Zirconia	Type 27	1	5
46088	4"	5/8"	120	High-Density	100% Zirconia	Type 27	1	5
46089	4 1/2"	7/8"	36	High-Density	100% Zirconia	Type 27	1	5
46090	4 1/2"	7/8"	40	High-Density	100% Zirconia	Type 27	1	5
46091	4 1/2"	7/8"	60	High-Density	100% Zirconia	Type 27	1	5
46092	4 1/2"	7/8"	80	High-Density	100% Zirconia	Type 27	1	5
46093	4 1/2"	7/8"	120	High-Density	100% Zirconia	Type 27	1	5
46094	4 1/2"	5/8"-11NC	36	High-Density	100% Zirconia	Type 27	1	5
46095	4 1/2"	5/8"-11NC	40	High-Density	100% Zirconia	Type 27	1	5
46096	4 1/2"	5/8"-11NC	60	High-Density	100% Zirconia	Type 27	1	5
46097	4 1/2"	5/8"-11NC	80	High-Density	100% Zirconia	Type 27	1	5
46098	4 1/2"	5/8"-11NC	120	High-Density	100% Zirconia	Type 27	1	5
46099	5"	7/8"	36	High-Density	100% Zirconia	Type 27	1	5
46100	5"	7/8"	40	High-Density	100% Zirconia	Type 27	1	5
46101	5"	7/8"	60	High-Density	100% Zirconia	Type 27	1	5
46102	5"	7/8"	80	High-Density	100% Zirconia	Type 27	1	5
46103	5"	7/8"	120	High-Density	100% Zirconia	Type 27	1	5
46104	7"	7/8"	36	High-Density	100% Zirconia	Type 27	1	5
46105	7"	7/8"	40	High-Density	100% Zirconia	Type 27	1	5
46106	7"	7/8"	60	High-Density	100% Zirconia	Type 27	1	5
46107	7"	7/8"	80	High-Density	100% Zirconia	Type 27	1	5
46108	7"	7/8"	120	High-Density	100% Zirconia	Type 27	1	5





ABRASIVE FLAP DISCS

TYPE 29

- For use on flat or curved surfaces
- Angle built into the disc - offers easier grinding action
- 20% more flaps than standard discs

BEVELED

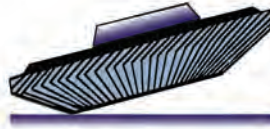

Premium 100% Zirconia:

Premium High Density Zirconia discs come with more flaps per wheel and give you long life products. Made of 100% Premium Zirconia, this is the highest quality grain and designed for Stainless Steel or harder metals and will last extremely long if used on regular steel.

PREMIUM PLATINUM JUMBO ZIRCONIA

Item#	Size	Arbor	Grit	Style	Grain	Shape	Pk. Qty	MP
46109	4"	5/8"	36	High-Density	100% Zirconia	Type 29	1	5
46110	4"	5/8"	40	High-Density	100% Zirconia	Type 29	1	5
46111	4"	5/8"	60	High-Density	100% Zirconia	Type 29	1	5
46112	4"	5/8"	80	High-Density	100% Zirconia	Type 29	1	5
46113	4"	5/8"	120	High-Density	100% Zirconia	Type 29	1	5
46114	4 1/2"	7/8"	36	High-Density	100% Zirconia	Type 29	1	5
46115	4 1/2"	7/8"	40	High-Density	100% Zirconia	Type 29	1	5
46116	4 1/2"	7/8"	60	High-Density	100% Zirconia	Type 29	1	5
46117	4 1/2"	7/8"	80	High-Density	100% Zirconia	Type 29	1	5
46118	4 1/2"	7/8"	120	High-Density	100% Zirconia	Type 29	1	5
46119	5"	7/8"	36	High-Density	100% Zirconia	Type 29	1	5
46120	5"	7/8"	40	High-Density	100% Zirconia	Type 29	1	5
46121	5"	7/8"	60	High-Density	100% Zirconia	Type 29	1	5
46122	5"	7/8"	80	High-Density	100% Zirconia	Type 29	1	5
46123	5"	7/8"	120	High-Density	100% Zirconia	Type 29	1	5
46124	7"	7/8"	40	High-Density	100% Zirconia	Type 29	1	5
46125	7"	7/8"	60	High-Density	100% Zirconia	Type 29	1	5
46126	7"	7/8"	80	High-Density	100% Zirconia	Type 29	1	5
46127	7"	7/8"	120	High-Density	100% Zirconia	Type 29	1	5

TYPE 27

- For use on flat or curved surfaces
- Aggressive shape disc
- 20% more flaps than standard discs
- More affordable

FLAT



Economy 100% Zirconia:

Economy High Density Zirconia discs come with more flaps per wheel and give you long life products. Made of 100% Economy Zirconia, this high quality grain is designed for Stainless Steel or harder metals and will last longer if used on regular steel.

PREMIUM ECONOMY JUMBO ZIRCONIA

Item#	Size	Arbor	Grit	Style	Grain	Shape	Pk. Qty	MP
46128	4"	5/8"	36	High-Density	100% Econ Zirconia	Type 27	1	5
46129	4"	5/8"	40	High-Density	100% Econ Zirconia	Type 27	1	5
46130	4"	5/8"	60	High-Density	100% Econ Zirconia	Type 27	1	5
46131	4"	5/8"	80	High-Density	100% Econ Zirconia	Type 27	1	5
46132	4"	5/8"	120	High-Density	100% Econ Zirconia	Type 27	1	5
46133	4 1/2"	7/8"	36	High-Density	100% Econ Zirconia	Type 27	1	5
46134	4 1/2"	7/8"	40	High-Density	100% Econ Zirconia	Type 27	1	5
46135	4 1/2"	7/8"	60	High-Density	100% Econ Zirconia	Type 27	1	5
46136	4 1/2"	7/8"	80	High-Density	100% Econ Zirconia	Type 27	1	5
46137	4 1/2"	7/8"	120	High-Density	100% Econ Zirconia	Type 27	1	5
46138	4 1/2"	5/8"-11NC	36	High-Density	100% Econ Zirconia	Type 27	1	5
46139	4 1/2"	5/8"-11NC	40	High-Density	100% Econ Zirconia	Type 27	1	5
46140	4 1/2"	5/8"-11NC	60	High-Density	100% Econ Zirconia	Type 27	1	5
46141	4 1/2"	5/8"-11NC	80	High-Density	100% Econ Zirconia	Type 27	1	5
46142	4 1/2"	5/8"-11NC	120	High-Density	100% Econ Zirconia	Type 27	1	5

ABRASIVE FLAP DISCS

PREMIUM ECONOMY JUMBO ZIRCONIA (CONT.)

Item#	Size	Arbor	Grit	Style	Grain	Shape	Pk. Qty	MP
46143	5"	7/8"	36	High-Density	100% Econ Zirconia	Type 27	1	5
46144	5"	7/8"	40	High-Density	100% Econ Zirconia	Type 27	1	5
46145	5"	7/8"	60	High-Density	100% Econ Zirconia	Type 27	1	5
46146	5"	7/8"	80	High-Density	100% Econ Zirconia	Type 27	1	5
46147	5"	7/8"	120	High-Density	100% Econ Zirconia	Type 27	1	5
46148	7"	7/8"	40	High-Density	100% Econ Zirconia	Type 27	1	5
46149	7"	7/8"	60	High-Density	100% Econ Zirconia	Type 27	1	5
46150	7"	7/8"	80	High-Density	100% Econ Zirconia	Type 27	1	5
46151	7"	7/8"	120	High-Density	100% Econ Zirconia	Type 27	1	5

TYPE 29

- For use on flat or curved surfaces
- Angle built into the disc - offers easier grinding action
- 20% more flaps than standard discs
- More affordable

Economy 100% Zirconia:

Economy High Density Zirconia discs come with more flaps per wheel and give you long life products. Made of 100% Economy Zirconia, this high quality grain is designed for Stainless Steel or harder metals and will last longer if used on regular steel.

BEVELED

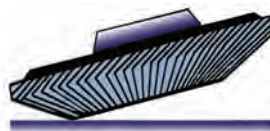

PREMIUM ECONOMY JUMBO ZIRCONIA

Item#	Size	Arbor	Grit	Style	Grain	Shape	Pk. Qty	MP
46152	4"	5/8"	36	High-Density	100% Econ Zirconia	Type 29	1	5
46153	4"	5/8"	40	High-Density	100% Econ Zirconia	Type 29	1	5
46154	4"	5/8"	60	High-Density	100% Econ Zirconia	Type 29	1	5
46155	4"	5/8"	80	High-Density	100% Econ Zirconia	Type 29	1	5
46156	4"	5/8"	120	High-Density	100% Econ Zirconia	Type 29	1	5
46157	4 1/2"	7/8"	36	High-Density	100% Econ Zirconia	Type 29	1	5
46158	4 1/2"	7/8"	40	High-Density	100% Econ Zirconia	Type 29	1	5
46159	4 1/2"	7/8"	60	High-Density	100% Econ Zirconia	Type 29	1	5
46160	4 1/2"	7/8"	80	High-Density	100% Econ Zirconia	Type 29	1	5
46161	4 1/2"	7/8"	120	High-Density	100% Econ Zirconia	Type 29	1	5
46162	4 1/2"	5/8"-11NC	36	High-Density	100% Econ Zirconia	Type 29	1	5
46163	4 1/2"	5/8"-11NC	40	High-Density	100% Econ Zirconia	Type 29	1	5
46164	4 1/2"	5/8"-11NC	60	High-Density	100% Econ Zirconia	Type 29	1	5
46165	4 1/2"	5/8"-11NC	80	High-Density	100% Econ Zirconia	Type 29	1	5
46166	4 1/2"	5/8"-11NC	120	High-Density	100% Econ Zirconia	Type 29	1	5
46167	5"	7/8"	36	High-Density	100% Econ Zirconia	Type 29	1	5
46168	5"	7/8"	40	High-Density	100% Econ Zirconia	Type 29	1	5
46169	5"	7/8"	60	High-Density	100% Econ Zirconia	Type 29	1	5
46170	5"	7/8"	80	High-Density	100% Econ Zirconia	Type 29	1	5
46171	5"	7/8"	120	High-Density	100% Econ Zirconia	Type 29	1	5
46172	7"	7/8"	40	High-Density	100% Econ Zirconia	Type 29	1	5
46173	7"	7/8"	60	High-Density	100% Econ Zirconia	Type 29	1	5
46174	7"	7/8"	80	High-Density	100% Econ Zirconia	Type 29	1	5
46175	7"	7/8"	120	High-Density	100% Econ Zirconia	Type 29	1	5



TYPE 27

**ALUMINUM OXIDE/ZIRCONIA
MINI FLAP DISCS**

These Mini Flap Discs are perfect for small grinding needs in tight spots. They replace Mini Grinding Discs, giving you improved longevity and a continual new surface! Available in 2" & 3" in either Aluminum Oxide or Zirconia, they come with a Twist-To-Lock backing.

- Non-Loading/ Never Curls
- Heavy Duty Built in Backing Pad
- Works on all High Speed Grinders
- Flat Face for Maximum Aggressiveness
- Outlast Mini Grinding Discs by 4-6 Times
- Available in Aluminum Oxide or Zirconia
- Uses 100% of the Grain Surface



	Item#	Size	Grit	Grain	Pk. Qty
ALUMINUM OXIDE	73752	2"	40	Aluminum Oxide	5
	73753	2"	60	Aluminum Oxide	5
	73754	2"	80	Aluminum Oxide	5
	73755	2"	120	Aluminum Oxide	5
	73757	3"	40	Aluminum Oxide	5
	73758	3"	60	Aluminum Oxide	5
	73759	3"	80	Aluminum Oxide	5
	73760	3"	120	Aluminum Oxide	5
ZIRCONIA	73762	2"	40	Zirconia	5
	73763	2"	60	Zirconia	5
	73764	2"	80	Zirconia	5
	73765	2"	120	Zirconia	5
	73767	3"	40	Zirconia	5
	73768	3"	60	Zirconia	5
	73769	3"	80	Zirconia	5
	73770	3"	120	Zirconia	5

MINI FLAP DISC KITS

These 6 piece Mini Flap Disc kits are a great mixture of grits for any type of job. The discs are designed for use on right angle die grinders, providing smooth grinding and enhanced conformability in tight areas where typical discs do not hold up.

Item#	Description
73750	2" Mini Flap Disc Kit includes: 2 - 40 Grit discs, 1 - 60 Grit disc, 1 - 80 Grit disc, 1 - 120 Grit disc and 1 - 2" holder.
73780	3" Mini Flap Disc Kit includes: 2 - 40 Grit discs, 1 - 60 Grit disc, 1 - 80 Grit disc, 1 - 120 Grit disc and 1 - 3" holder.

CUP STYLE

ZIRCONIA MINI CUP FLAP DISCS

Suited for contoured surfaces. More flexible and conformable compared to mini discs.

- Non-Loading
- Heavy Duty Built in Backing Pad
- Works on all High Speed Grinders
- Beveled Face for Maximum Contact
- Perfect for Rounded and Curved Surfaces
- Uses 100% of the Grain Surface

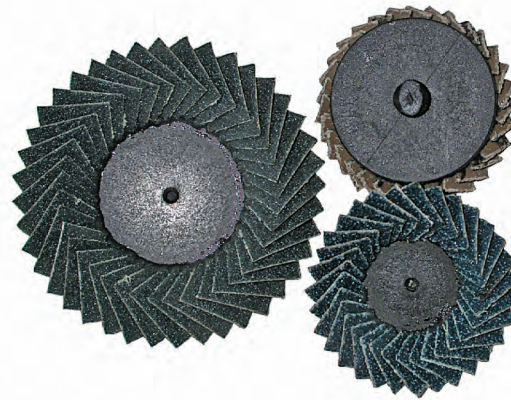

Item#	Size	Grit	Grain	Pk. Qty
82751	2"	40	Zirconia	2
82752	2"	60	Zirconia	2
82753	2"	80	Zirconia	2
82754	2"	120	Zirconia	2
83751	3"	40	Zirconia	2
83752	3"	60	Zirconia	2
83753	3"	80	Zirconia	2
83754	3"	120	Zirconia	2



ALUMINUM OXIDE FLAP WHEELS

These mini grinding flap wheels replace many wire brushes, cartridge rolls, and mounted points in metal removal applications. Made of Aluminum Oxide abrasive grain for excellent performance, they are resin bonded to a cloth back. Excellent for polishing, contouring, dry sanding and grinding applications. Also used in rust removal, descaling and deburring. All have a 1/4" shank.



Cloth Backing:

Cloth backings are strong and durable. The wheel is designed for long life; and coarse grits offer heavy stock removal.

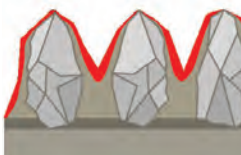

Resin Bonded:

Strongest and most resistant bond available. Stands up to high speed and pressure sanding or grinding applications.

Item#	Old #	Dia.	Height	Grit	RPM	Pk. Qty
13099	F1140	1"	1/2"	40	30,000	5
13100	F1160	1"	1/2"	60	30,000	5
13101	F1180	1"	1/2"	80	30,000	5
13102	F1100	1"	1/2"	10	30,000	5
13103	F1200	1"	1/2"	120	30,000	5
13104	F1340	1"	1"	40	30,000	5
12912		1"	1"	60	30,000	1
13105	F1360	1"	1"	60	30,000	5
12913		1"	1"	80	30,000	1
13106	F1380	1"	1"	80	30,000	5
13107	F13100	1"	1"	100	30,000	5
12914		1"	1"	120	30,000	1
13108	F13120	1"	1"	120	30,000	5

Item#	Old#	Dia.	Height	Grit	RPM	Pk. Qty
13109	F1340	1 1/2"	1/2"	40	30,000	5
12915		1 1/2"	1/2"	60	30,000	1
13110	F1460	1 1/2"	1/2"	60	30,000	5
12916		1 1/2"	1/2"	80	30,000	1
13111	F1480	1 1/2"	1/2"	80	30,000	5
13112	F14100	1 1/2"	1/2"	100	30,000	5
12917		1 1/2"	1/2"	120	30,000	1
13113	F14120	1 1/2"	1/2"	120	30,000	5
13114	F1540	1 1/2"	1"	40	30,000	5
13115	F1560	1 1/2"	1"	60	30,000	5
13116	F1580	1 1/2"	1"	80	30,000	5
13117	F15100	1 1/2"	1"	100	30,000	5
13118	F15120	1 1/2"	1"	120	30,000	5
13119	F240	2"	1"	40	25,000	5
12918		2"	1"	60	25,000	1
13120	F260	2"	1"	60	25,000	5
12919		2"	1"	80	25,000	1
13121	F280	2"	1"	80	25,000	5
13122	F2100	2"	1"	100	25,000	5
12920		2"	1"	120	25,000	1
13123	F2120	2"	1"	120	25,000	5
13124	F2140	2 1/2"	1"	40	25,000	5
13125	F2160	2 1/2"	1"	60	25,000	5
13126	F2180	2 1/2"	1"	80	25,000	5
13127	F21100	2 1/2"	1"	100	25,000	5
13128	F21200	2 1/2"	1"	120	25,000	5
13129	F3140	3"	1"	40	20,000	5
12921		3"	1"	60	20,000	1
13130	F3160	3"	1"	60	20,000	5
12922		3"	1"	80	20,000	1
13131	F3180	3"	1"	80	20,000	5
13132	F31100	3"	1"	100	20,000	5
12923		3"	1"	120	20,000	1
13133	F31120	3"	1"	120	20,000	5



ALUMINUM OXIDE FLAP WHEELS

FLAP WHEEL ASSORTMENT PACK

A handy assortment of sizes and grits in an attractive clam shell package! Made from Aluminum Oxide cloth backed sandpaper, this wheel assortment will be a great starter kit for the person who requires a variety of sizes and grits. All have a 1/4" shank.

Tool: Electric Angle Grinder, Pneumatic Die Grinders or Drills

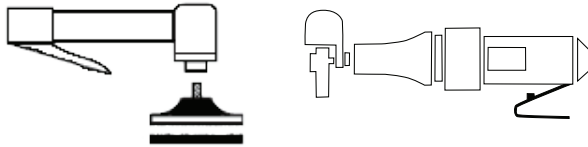

Item#	Description
7000	Item# Size Grit Qty.
	13103 (1) 1" x 1/2" 120 1
	13104 (1) 1" x 1" 40 1
	12913 1" x 1" 80 1
	13115 (1) 1 1/2" x 1" 60 1
	13116 (1) 1 1/2" x 1" 80 1
	12918 2" x 1" 60 2
	12919 2" x 1" 80 1



NEW! ZIRCONIA CARTRIDGE ROLLS

The Zirconia cartridge rolls are best for deburring and blending in small, hard to reach places. The handy rolls are constructed of Zirconia with a cloth back and sealed with a heat-resistant resin bond.

These long-life rolls can be used on ferrous metals, high-tensile materials, aircraft grade aluminum, and stainless steel, as well as heat treated steels. Harder and stronger than aluminum oxide, their performance will impress you.

Made in the U.S.A.

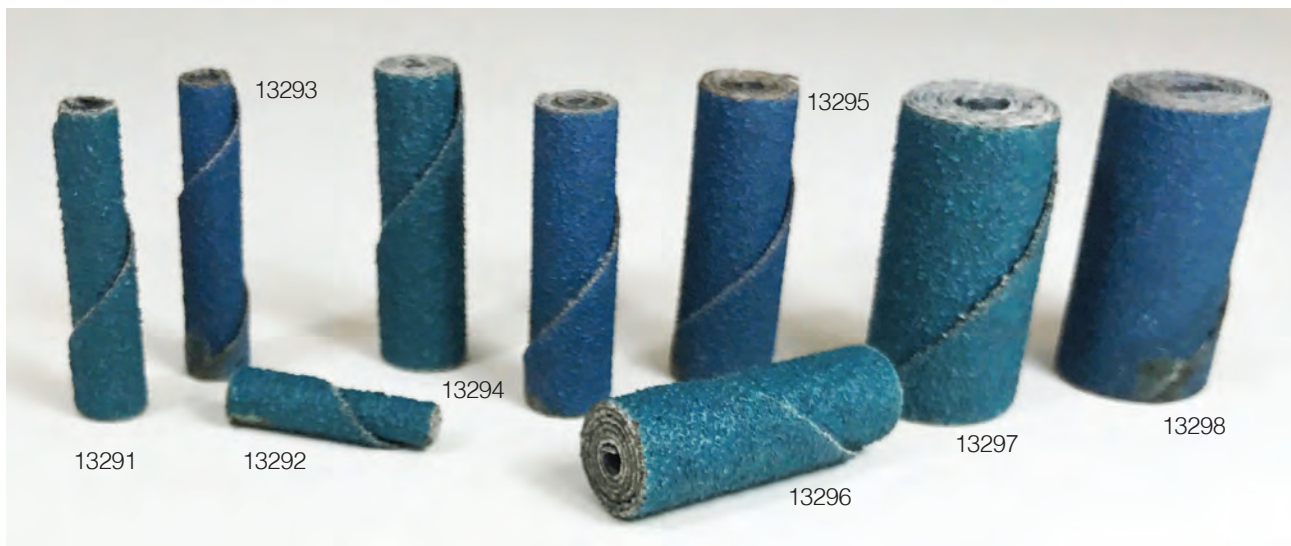

Item#	Description	Grit	Qty.
13290	1/4" x 1-1/2" x 1/8"	60	100
13291	1/4" x 1-1/2" x 1/8"	80	100
13292	3/16" x 1-1/2" x 3/32"	60	100
13293	3/8" x 1-1/2" x 1/8"	60	100
13294	3/8" x 1-1/2" x 1/8"	80	100
13295	1/2" x 1-1/2" x 1/8"	60	100
13296	1/2" x 1-1/2" x 1/8"	80	100
13297	3/4" x 1-1/2" x 1/4"	60	100
13298	3/4" x 1-1/2" x 1/4"	80	100
13299	3/8" x 1-1/2" x 1/4"	36	100
13300	3/4" x 1-1/2" x 1/4"	36	100
13301	3/4" x 2" x 1/4"	36	100
13303	3/4" x 2" x 1/4"	60	100

PILOT LENGTH FOR MANDRELS

Rolls 1" Long - 3/4" pilot length.

Rolls 1/2" Long - 1" pilot length.

Rolls 2" Long - 1 1/2" pilot length.

Item#	Size	Description
13312	3/32" x 3/4" x 1/4"	OAL 2-3/4
13313	1/8" x 1" x 1/4"	OAL 2-3/4
13314	1/4" x 1" x 1/4"	OAL 3"
13315	1/4" x 1" x 1/4"	OAL 6"
13316	1/8" x 1" x 1/4"	OAL 8"





SHARK INDUSTRIES

Mounted Points

- ▶ General Purpose
- ▶ Weld Grinding
- ▶ Tire Applications
- ▶ Extra Coarse
- ▶ Assortments





MOUNTED POINTS

Shark Mounted Points are high quality, vitrified mounted points. Typical applications include blending contours, deburring molded parts and mold finishing, ID grinding, off hand bench grinding, and tool and die applications. All mounted points are sold separately or in various assortments.

STANDARD SHAPES

Series A: Shapes are mounted on 1/4" diameter by 1 1/2" long shanks. Available in all shapes.

Series W: Cylindrical point shapes.

SELECTION OF HARDNESS GRADE

Below is a Hardness chart to help gage what level will work best for your project.

I	J	K	L	M	N	O	P	Q	R	S	T	U	V	W	X	Y	Z
			very soft	soft		medium			hard					very hard			

Vitrified Bond Types



Salmon: They are typically used in medium (**R**) hardness for stock removal of steel.



Pink: Used in almost every industry but primarily in tool and die shops, and foundries. General applications: Deburring, tool sharpening, finishing cavities, and removing mold marks and parting lines. The semi-friable pink PA abrasive is used to produce sharp, consistent cutting action. Typically is a medium (**O thru Q**) hardness stock.



White: They are typically used in soft to medium (**L thru R**) wheels for stock removal of harder steel. They are also frequently used in very soft wheels for jig grinding or internal grinding.



Salmon Coarse: Typically used in hard (**U**) hardness applications. For use in very aggressive and durable material application.



Grey: Hardness grade (**R**) mounted points are noted for their durability and used primarily for grinding welds.

Size Diagram & Terms

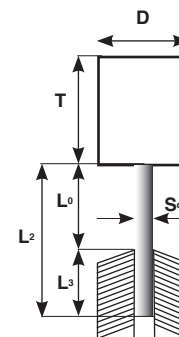

- D = Point Diameter
- T = Point Length
- S_d = Shank Diameter
- L^0 = Overhang
- L^2 = Shank Length
- L^3 = Shank Clamping Depth

MOUNTED POINTS

Series A: Shapes are mounted on 1/4" diameter by 1 1/2" long shanks. Available in most shapes.

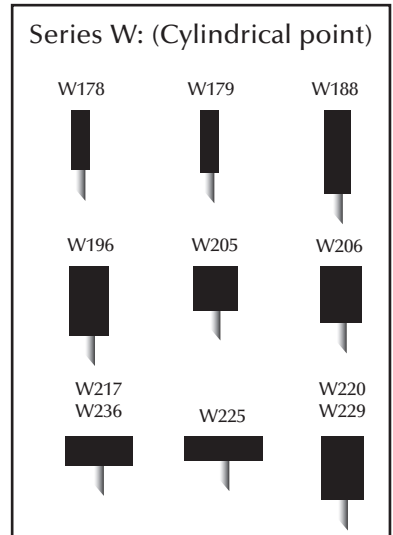
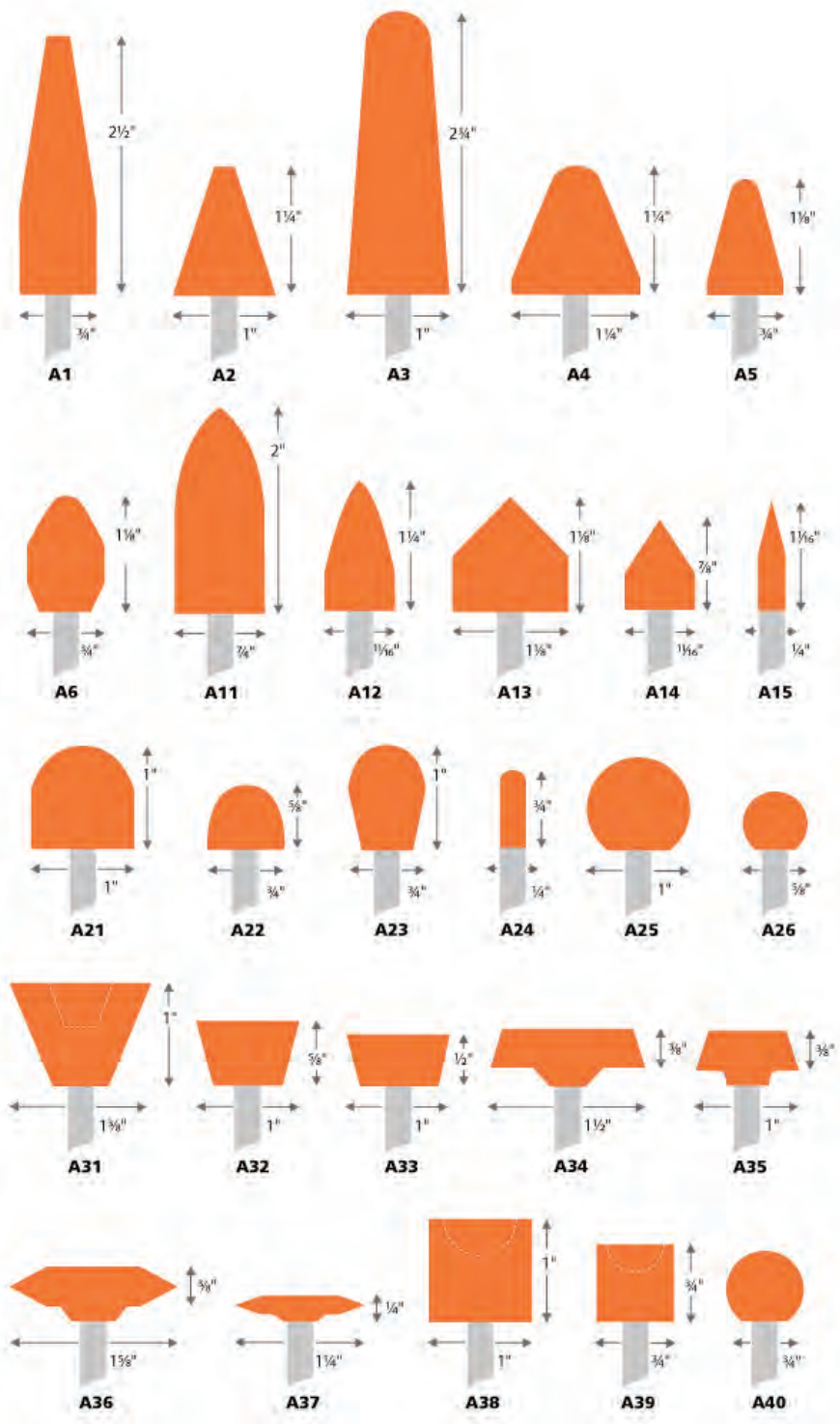



MOUNTED POINTS

Below is a chart showing the wide range of mounted points that we offer. The 5 different types of Aluminum Oxide will fit with all your project needs. All mounted points are sold separately or in various assortments.

Shark Important Notice: Use caution at all times. Comply with ANSI B7-1 and OSHA Regulations. Shark cannot be held liable for personal injury incurred when not complying with OSHA Regulations.

Style#	Dia.	Height	RPM	Grey	Salmon	Pink	White	Salmon Coarse
				Shark Part # WELDING	Shark Part #	Shark Part #	Shark Part #	Shark Part #
A1	1/4"	2 1/2"	19,800		A1P	A1W		A1S
A2	1"	1 1/4"	38,000	12800	A2P	A2W		A2S
A3	1"	2 3/4"	16,100		A3P	A3W		A3S
A4	1 1/4"	1 1/4"	30,560	12793	A4P	A4W		A4S
A5	3/4"	1 1/8"	45,000	12794	A5P	A5W	A5SC	A5S
A11	7/8"	2"	19,860	12795	A11P	A11W		A11S
A12	11/16"	1 1/4"	48,000	12796	A12P	A12W	A12SC	A12S
A13	1 1/8"	1 1/8"	33,950		A13P	A13W		A13S
A14	11/16"	7/8"	55,560		A14P	A14W		A14S
A15L	1/4"	1 1/16"	26,250		A15LP	A15LW		A15LS
A15	1/4"	1 1/16"	72,750	12797	A15P	A15W		A15S
A21	1"	1"	34,500		A21P	A21W		A21S
A23	3/4"	1"	39,370	12798	A23P	A23W		A23S
A24	1/4"	3/4"	76,500	12799	A24P	A24W		A24S
A25	1"	1"	35,610	12801	A25P	A25W	A25SC	A25S
A26	5/8"	5/8"	61,120		A26P	A26W		A26S
A31	1 3/8"	1"	27,780		A31P	A31W		A31S
A32	1"	5/8"	38,200		A32P	A32W	A32SC	A32S
A34	1 1/2"	3/8"	25,470		A34P	A34W		A34S
A36	1 5/8"	3/8"	23,520		A36P	A36W		A36S
A37	1 1/4"	1/4"	30,560		A37P	A37W		A37S
A38	1"	1"	34,500	12802	A38P	A38W	A38SC	A38S
A39	3/4"	3/4"	47,250		A39P	A39W		A39S
W178	3/8"	1"	55,200		W178P	W178W		W178S
W179	3/8"	1 1/4"	45,750		W179P	W179W	W179SC	W179S
W187	1/2"	1"	40,500		W187P	W187W		W187S
W188	1/2"	1 1/2"	30,370		W188P	W188W		W188S
W196	5/8"	1"	35,250		W196P	W196W	W196SC	W196S
W205	3/4"	1"	34,500		W205P	W205W	W205SC	W205S
W206	3/4"	1 1/4"	28,720		W206P	W206W		W206S
W216	1"	1/4"	38,200		W216P	W216W		W216S
W217	1"	3/8"	38,200		W217P	W217W	W217SC	W217S
W218	1"	1/2"	38,200	12803	W218P	W218W		W218S
W220	1"	1"	25,500	12804	W220P	W220W		W220S
W225	1 1/4"	1/4"	30,560		W225P	W225W	W225SC	W225S
W229	1 1/4"	1"	24,000		W229P	W229W		W229S
W235	1/2"	1/4"	25,470		W235P	W235W	W235SC	W235S
W236	1 1/2"	1/2"	25,470		W236P	W236W		W236S

MOUNTED POINT KITS

MOUNTED POINT DISPLAY BOX

PART # 114

Specifications:

This 48 Piece Assortment of Mounted Points comes in a convenient display pack. These professional points are the finest quality and shouldn't be confused with inexpensive mounted points usually offered in displays such as this.

Set Includes:

A1S, A3S, A4S, A11S, A12S, A13S, A21S, A23S, A25S, A31S, A36S, A37S, A38S, W178S, W188S, W206S, W225S, W236S



48 Piece Assortment Set

10 PIECE COARSE STONE SET

PART # AW10

Specifications:

This 10 Piece Assortment of Mounted Points comes in a convenient display box. These professional points are for faster stock removal.

Coarseness: 24 - 36 Grit

Set Includes:

A5SC, A12SC, A32SC, A38SC, W179SC, W196SC, W205SC, W127SC, W225SC, W235SC



MOUNTED POINT STONE SETS

PART# AW7

General Purpose Salmon Stone for Professional General Use

Kit Includes:

A1S, A12S, A37S, A38S, W178S, W188S, W225S



PART# AW5S

General Purpose Salmon Stone for Professional General Use

Kit Includes:

A1S, A12S, A38S, W178S, W188S



PART# AW5

Extra Hard Pink Stone for Machine Shop Engine Rebuilding Use

Kit Includes:

A1P, A12P, A38P, W178P, W188P



ALUMINUM OXIDE MINI-MOUNTED GRINDING WHEELS

Specifications:

Made from vitrified Aluminum Oxide. All wheels use a 1/4" diameter mandrel and work with any electric drill. (Mandrel included.)

Best For:

Use on carbon steel, wrought iron or bronze.

Item#	Size	Grit	RPM	Qty.
12787	1" x 1"	60	3,450	1
12788	1 1/2" x 1"	60	3,450	1
12789	2" x 1/4"	60	3,450	1
12790	2" x 1/2"	60	3,450	1
12791	2 1/2" x 1/4"	60	3,450	1
12792	2 1/2" x 1/2"	60	3,450	1
12936	Mounted Wheel Mandrel With 1/4" Arbor			

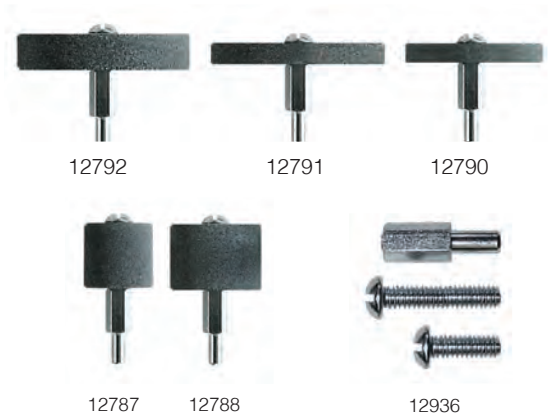



SHARK INDUSTRIES

Bench Seat Wheels

- ▶ Aluminum Oxide
General Purpose
- ▶ Silicon Carbide
Resharpener





BENCH SEAT GRINDING WHEEL ACCESSORIES

GRINDING WHEEL SHAPES

TYPE 1 An all around edge grinding wheel design. Not used for cutting.

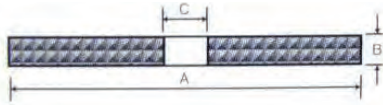

HOW TO PICK THE RIGHT GRAIN TYPE

ALUMINUM OXIDE

This bond offers longer life and excellent stock removal. Recommended on structural steel, metal and welds.

SILICON CARBIDE

Silicon carbide grain for reshaping and dressing tools.

BENCH SEAT GRINDING WHEEL-ACCESSORIES

GRINDING WHEEL DRESSER

Made of heavy cast iron, this dresser is for use with wheels up to 10" diameter and widths up to 2".



Item#	Size	Pk. Qty.
12932	10 1/2" Long	1

DRESSING STONE

Grinding wheel dressing stone is used when redressing Type 1 bench grinding wheels.



Item#	Diameter	Grit	Pk. Qty.
12934	6"x1"x1"	24	1

REPLACEMENT CUTTERS

Made from high carbon steel with long lasting teeth. Hardened for long life service and proper dressing action. Also includes two spacers.



Item#	Diameter	Hole	Face	Pk. Qty.
12933	1 1/4"	1/4"	.426"	1

BENCH GRINDER ADAPTORS

These adaptors are designed to nest or telescope to fit the various needs of your arbor. Made from heavy duty plastic, they are designed to adapt wheels with 1" or 1-1/4" arbors to fit 1/2", 5/8", 3/4" or 1" shafts. Three thickness options available!



Item#	Description	Pk. Qty.
12783	1/2" Thick, 3/4", 5/8", 1/2" O.D.	1 unit of 3
12784	3/4" Thick, 3/4", 5/8", 1/2" O.D.	1 unit of 3
12785	1" Thick, 3/4", 5/8", 1/2" O.D.	1 unit of 3
12786	1" Thick, 1-1/4", 1", 3/4", 5/8", 1/2" O.D.	1 unit of 4

BENCH SEAT GRINDING WHEELS

TYPE 1 - VITRIFIED BENCH GRINDING WHEELS

Made from Aluminum Oxide or *Silicon Carbide, vitrified bonded grinding wheels with a 1" arbor hole are used on stationary bench grinders. All Wheels include adaptors to fit 1/2", 5/8" & 3/4" arbors eliminating costly inventory duplication. Use for general purpose sharpening and grinding of mild steel.



Item#	Old#/Description	Diameter	Width	Grit	Arbor	Insert	RPM
2012G*	Silicon Carbide	6"	1/2"	120	1"	1/2-5/8-3/4"	3850
2016G*	Silicon Carbide	6"	3/4"	120	1"	1/2-5/8-3/4"	3850
2004		4"	1/2"	46	1/2"	No Insert	6500
2009		5"	1/2"	36	1/2"	No Insert	4900
2010		5"	1/2"	46	1/2"	No Insert	4900
2011		5"	1/2"	60	1/2"	No Insert	4900
2006		5"	3/4"	46	1/2"	No Insert	4900
2007		5"	1"	24	1/2"	No Insert	4900
2008		5"	1"	36	1/2"	No Insert	4900
2012**		6"	1/2"	36	1"	1/2-5/8-3/4"	3850
2013**		6"	1/2"	46	1"	1/2-5/8-3/4"	3850
2014**		6"	1/2"	60	1"	1/2-5/8-3/4"	3850
2015**		6"	1/2"	80	1"	1/2-5/8-3/4"	3850
12771**	2016	6"	3/4"	36	1"	1/2-5/8-3/4"	3850
2017**		6"	3/4"	46	1"	1/2-5/8-3/4"	3850
12772**	2018	6"	3/4"	60	1"	1/2-5/8-3/4"	3850
12773**	2019	6"	3/4"	80	1"	1/2-5/8-3/4"	3850
2019-10		6"	3/4"	100	1"	1/2-5/8-3/4"	3850
12774**	2020	6"	1"	36	1"	1/2-5/8-3/4"	3850
2021**		6"	1"	46	1"	1/2-5/8-3/4"	3850
12775**	2022	6"	1"	60	1"	1/2-5/8-3/4"	3850
12776**		6"	1"	80	1"	1/2-5/8-3/4"	3850
2022-10**		6"	1"	100	1"	1/2-5/8-3/4"	3850
2023		7"	3/4"	36	1"	1/2-5/8-3/4"	3600
2024		7"	3/4"	46	1"	1/2-5/8-3/4"	3600
2025		7"	1"	24	1"	1/2-5/8-3/4"	3600
12777	2026	7"	1"	36	1"	1/2-5/8-3/4"	3600
2027		7"	1"	46	1"	1/2-5/8-3/4"	3600
12778	2028	7"	1"	60	1"	1/2-5/8-3/4"	3600
12779	2028-80	7"	1"	80	1"	1/2-5/8-3/4"	3600
2029		8"	3/4"	36	1"	1/2-5/8-3/4"	3450
2030		8"	3/4"	46	1"	1/2-5/8-3/4"	3450
2031		8"	3/4"	60	1"	1/2-5/8-3/4"	3450
2032-24		8"	1"	24	1"	1/2-5/8-3/4"	3450
12780	2032	8"	1"	36	1"	1/2-5/8-3/4"	3450
2033		8"	1"	46	1"	1/2-5/8-3/4"	3450
12781	2034	8"	1"	60	1"	1/2-5/8-3/4"	3450
2035-24		10"	1 1/4"	24	1"	1-1 1/4"	2483
2035		10"	1 1/4"	36	1"	1-1 1/4"	2483
2035-46		10"	1 1/4"	46	1"	1-1 1/4"	2483
2036		10"	1 1/4"	36	1 1/4"	1-1 1/4"	2483
2037		10"	1 1/2"	36	1 1/4"	1-1 1/4"	2483
2038		12"	2"	24	1 1/4"	1-1 1/4"	2069
2039		12"	2"	36	1 1/4"	1-1 1/4"	2069

**Comes in a clam shell package



Welders-Helmets

- ▶ Mig Welders
- ▶ Spool Guns
- ▶ Plastic Tack Welders
- ▶ Welding Carts
- ▶ Welding Helmets
- ▶ Welding Lenses





WELDERS

MIG 140EN KIT

The Shark 115/120 Volt do-it-yourself welder is perfect for the starter or infrequent user. This affordable welder offers many easy-to-use features and comes with additional accessories. It can be used with or without gas. It is capable of welding up to 3/16" thick metal and is great for home or automotive infrequent users. The 130 Amp welder is offered in 2 versions; with or without a complete accessory package. The unit features a dual groove drive roller for ease of welding with either .023 or .030 wire. (See breakdowns below.)

Features & Benefits:

- Dual groove drive roller
- Thermostatic heat protection
- Infinite wire speed control



17010

Item# Welder with Kit Includes:

17010 6 ft. Tweco style mig torch, 6 ft. grounding cable & earth clamp, .023 & .030 contact tips, chipping hammer, 1/2 lb., .030 flux core wire, dual gauge regulator, gas hose & 2 hose clamps, welding cart, welding gloves and hand held welding shield. Shipping weight: 82 lbs.

Item# Welder without Kit:

17020 6 ft. Tweco style mig torch, 6 ft. grounding cable and earth clamp, .023 & .030 contact tips, chipping hammer, 1/2 lb. .030 flux core wire, dual gauge regulator, gas hose and 2 hose clamps. Shipping weight: 51 lb.

17026 Gauge and nylon hose set - 2 lbs.



17020

Max. Output	Duty Cycle	Current range	Wide dia. range	Input voltage/settings.	Max welding thickness	Shipping wt.
130 Amps	65 Amps at 20%	20-130 Amps	.023-.030	115/4	3/16"	82 lbs.

WELDERS

MIG 190EN KIT

The Shark 230 Volt Mig welder is a do-it-your-self's grade welder; but not recommended for Industrial applications. This welder achieves 145 Amps at 15% duty cycle. It is capable of welding up to 1/4" thick metal.

This affordable welder offers many easy-to-use features and comes with additional accessories. It can be used with or without gas. The 180 Amp welder is offered in 2 versions; with or without a complete accessory package. The unit features a dual groove drive roller for ease of welding with either .023 or .035 wire.

Features & Benefits:

- Dual groove drive roller
- Thermostatic heat protection
- Infinite wire speed control

Item#	Welder with Kit Includes:
17011	6 ft. Tweco style mig torch, 6 ft. grounding cable and earth clamp, .035 & .023 contact tips, chipping hammer, 1/2 lb. .030 flux core wire, dual gauge regulator, gas hose and 2 hose clamps, welding cart, welding gloves and hand held welding shield. Shipping weight: 99 lbs.
Item#	Welder without Kit:
17021	6 ft. Tweco style mig torch, 6 ft. grounding cable and earth clamp, .035 & .023 contact tips, chipping hammer, 1/2 lb. .030 flux core wire, dual gauge regulator, gas hose and 2 hose clamps. Shipping weight: 68 lbs.
17026	Gauge and nylon hose set - 2 lbs.



Max. Output	Duty Cycle	Current range	Wide dia. range	Input voltage/settings.	Max welding thickness	Shipping wt.
180 Amps	145 Amps at 15%	20-180 Amps	.023-.035	230/5	1/4"	99 lbs.



WELDERS

MIG 135 KIT

The Shark 115/120 Volt welder is an upgrade from our MIG 140EN and offers a higher Amp Duty Cycle. Designed for the light/professional user, this affordable welder offers many easy-to-use features and comes with additional accessories. It can be used with or without gas. It is capable of welding up to 3/16" thick metal and is great for farm or automotive users. The 135 amp welder is offered in 2 versions; with or without a complete accessory package. The unit features a dual groove drive roller for ease of welding with either .023 or .035 wire.

Features & Benefits:

- Dual groove drive roller
- Thermostatic heat protection
- Infinite wire speed control

Item# Welder with Kit Includes

17012 6 ft. Tweco style mig torch, 6 ft. grounding cable and earth clamp, .035 & .023 contact tips, chipping Hammer, 1/2 lb. .030 flux core wire, dual gauge regulator, gas hose, 2 hose clamps, welding cart, welding gloves and auto-dark helmet. Shipping weight: 95 lbs.

Item Welder without Kit

17022 6 ft. Tweco style mig torch, 6 ft. grounding cable and earth clamp, .035 & .023 contact tips, chipping hammer, 1/2 lb. .030 flux core wire, dual gauge regulator, gas hose, and 2 hose clamps. Shipping weight: 58 lbs.



Max. Output	Duty Cycle	Current range	Wide dia. range	Input voltage/settings.	Max welding thickness	Shipping wt.
135 Amps	80 Amps at 20%	20-100 Amps	.023-.035	115/4	3/16"	95 lbs.

WELDERS

SK 140i WELDER

SK140i is a Portable AC input and DC output MIG welder capable of welding with solid wire (with shielding gas) or flux core wire.

Features & Benefits:

- Wire feed
- Spool gun ready
- Ultimate control on Mild Steel, Stainless Steel and Aluminum
- Capable of welding 24 gauge to 3/16" Steel in a single pass
- Infinite wire feed
- Voltage controls
- 115 Volt power source
- Delivers 30-140 Amps; with 20% duty cycle at 80 Amps
- Spot Timer delivers consistently timed welds
- Weld with or without shielding gas

Item#	Welder
17018	Welder, 10 ft. Mig Gun, 10 ft. ground cable & 200 Amp earth clamp, regulator and gas hose, 8 ft. power cord.



17018

Max. Output	Duty Cycle	Current Range	Wire diameter range	Input voltage/Settings	Max welding thickness	Shipping wt.
140 Amps	20% at 80 Amps	25-80 Amps	.023-.035	115 volt	3/16"	53 lbs.



WELDERS

MIG SK180i WELDER

The Shark 230 Volt Mig welder is the light/professional grade welder; but not recommended for Industrial applications. It can be used with or without gas. It is capable of welding up to 1/4" thick metal. This heavy duty welder achieves 145 amps at 20% duty cycle. The unit features a dual groove drive roller for ease of welding with either .023 or .035 wire. (See breakdown below.)

Features & Benefits:

- Dual groove drive roller
- Thermostatic heat protection
- Infinite wire speed control



Item	Welder
17023	6 ft. Tweco style mig torch, 6 ft. grounding cable and earth clamp, .035 & .023 contact tips, chipping hammer, dual gauge regulator, gas hose and 2 hose clamps. Shipping weight: 44 lbs.



Max. Output	Duty Cycle	Current range	Wide dia. range	Input voltage/settings.	Max welding thickness	Shipping wt.
180 Amps	20% at 145 Amps	25-145 Amps	.023-.035	230/5	1/4"	44 lbs.

WELDERS

SW-MIG/STICK 140 KIT

The new upgraded Shark SW-140 Mig/Stick Welder (115 volt) is the medium duty to professional grade welder that can now do stick as well as MIG welding. This upgraded welder offers a 10 foot removable MIG torch with Tweco style replacement parts. It features a 10 foot detachable ground cable. It will weld up to 1/4" thick metal and is great for automotive users. (See accessories below).

Features & Benefits:

- Dual groove drive roller
- Thermostatic heat protection
- Infinite wire speed control
- Inverter



Item#	Welder with Kit Includes
17024	10 ft. Tweco® style mig torch, 10 ft. grounding cable and 200 Amp earth clamp, .035 & .023 contact tips, 1/2 lb. .030 flux core wire, dual gauge regulator, gas hose and 2 hose clamps. Shipping weight: 40 lbs.

Max. Output	Duty Cycle	Current range	Wire diameter range	Input voltage/ settings.	Max welding thickness	Shipping wt.
140 Amps	30% at 90 Amps	30-130 Amps	.023-.035	115/5	1/4"	40 lbs.

SW-MIG/STICK/TIG 200

The new upgraded Shark 230 Volt Mig/Stick/Tig Welder is our top-of-the-line professional grade welder. It's now a 3-in-1 welder accomodating both Stick and Tig welding as well as Mig. This heavy duty welder achieves 160 amps at 30% duty cycle. It will weld up to 1/4" thick metal. It includes a 10 foot detachable Tweco Style Mig Gun compatible with Tweco replacement parts and 10 foot removable ground clamp. The unit includes a dual groove drive roller for ease of welding. (See accessories below)

Features & Benefits:

- Dual groove drive roller
- Thermostatic heat protection
- Infinite wire speed control
- Inverter



Item#	Includes
17025	10 ft. Tweco® style mig torch, 10 ft. grounding cable and 200 Amp earth clamp, .035 & .023 contact tips, 1/2 lb. .030 flux core wire, dual gauge regulator, gas hose and 2 hose clamps. Shipping weight: 44 lbs.

Max. Output	Duty Cycle	Current Range	Wire diameter range	Input voltage/ Settings	Max welding thickness	Shipping wt.
180 Amps	30% at 160 Amps	30-200 Amps	.023-.035	230/5	1/4"	44 lbs.



WELDING SPOOL GUN

3 CONNECTOR SPOOL GUN

This spool gun has three specialized connectors for use with multiple Shark welders. The 3 connector spool gun can work with the MIG/STICK 140W, the MIG /STICK/TIG 200W, the SK 140i, as well as the new SK 180i.

Designed for use with wire that is difficult to feed through the standard MIG gun (such as aluminum). It can also be used with other types of wire. The 4" spool is mounted inside the gun instead of in the machine; which greatly reduces the spool-to-tip distance and eliminates most wire feeding issues.

The spool gun is rated at 200 Amps when using CO2 gas and 160 amps when using mixed gas. With a 35% duty cycle, the unit is ideal for light fabrication and welding repairs.

The gun is capable of using .023, .030 and .035 wire.



Item#	Cord Length	Wt.
17016	10 Ft.\	5 lbs.

Max. Output	Cooling Method	Duty Cycle	Suggested Wire	Maximum Wire Spool Diameter	Wire Speed	Cord Length	MIG Gun connection	Contact Tips & Nozzle
200A using CO2 Gas 160A using Argon/Argon Mix Gas	Air-Cooled	35%	.023-.035 MIG (solid) wire .030-.035 Flux core wire .030-.035 Aluminum wire	4" spool	0 to 630 IPM	10 ft.	TWECO® Style	TWECO® Style Series 11



Now ETL approved!



Intertek

PLASTIC WELDER

PRO-TACK PLASTIC WELDER

The new Pro-Tack Welder is an eco-friendly welder, drawing only 5 amps with a maximum output of 65 amps, and is great for repairing virtually anything made of plastic. It can fix everything from car bumpers to wheelbarrows. It is as good for Industrial use as it is for automotive and soldering applications. Unlike most other plastic welders, it is rated to a maximum of 65 amps, giving it the capability of ironing plastic, and has 4 power settings. Our unique core-cut staples easily break off without cutting, affording an advantage over other staples. It comes with 2 additional patented ironing tools that go over the 2 probes for smoothing the plastic after welding.

When you compare this welder to the time-consuming plastic welders requiring plastic rods, this is a much quicker fix that adds the stability of metal staples; making the end result much stronger!

Features & Benefits:

- 4 heat settings
- LED read out
- Repairs bumpers and plastic auto parts (car & motorcycle)
- Capable of ironing plastic to a smooth finish
- Rapid heating and cooling
- Soldering capabilities

Item#	Description
17045	Welder, 4 staple shapes (17031 (20), 17033 (20), 17034 (20), 17036 (40)), 2 ironing blades, plastic box for staples, and a plastic storage case. Shipping weight: 10 lbs.
17039	Pro-Tack Plastic Welder (Separate Non-Kit)
17040	Plastic Tack Welder Flat Iron Blade
17041	Plastic Tack Welder Angle Iron Blade

Staple Options
Staples sold separately.
100 Per Pack.

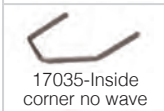
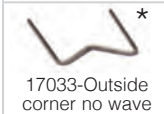
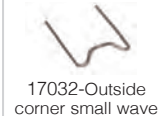
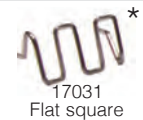

17038 Pack of 400 Staples
100 Each Staples Below



*Included with welder 17045



• Stapling
A large variety of core cut staples for tacking or seaming.

• Ironing Surface
Heating / melting / ironing the surface, to strengthen the durability and life 2 Types-Flat and 45°

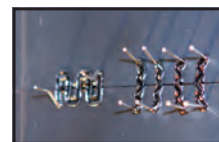
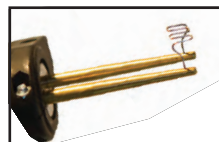

Max. Output	Current range	Input voltage/settings.	Dimension:	Shipping wt.
65 Amps	10-65 Amps	115/5	8 3/4" x 5 1/4" x 4 3/4"	10 lbs.

*Not to be used on fiberglass

**Welder's appearance may vary



Now ETL approved!



Intertek

PLASTIC WELDER

PRO-TACK MINI PLASTIC WELDER

The Mini Pro-Tack Welder is eco-friendly like the Pro-Tack Welder and is great for repairing almost anything plastic. Two new functions give you the ability to heat/cut, repair holes, and solder lead-tin items. The 110 volt tool gives you a 45 amp output when welding and a 5-10 amp output when stapling. Uses all 7 styles of staples shown on page 93.

Features & Benefits:

- Easy to use
- Low voltage output
- Safe and Reliable (with overheating protection)
- Quick heating and cooling
- Convenient

Item#	Welder with Kit Includes
17046	Storage case with welding/stapling tool, and 1 ironing blade. Includes 4 staple shapes (17031, 17033, 17034, 17036) with 10 of each. Staples are made of chromium alloy.

17043	Replacement ironing blade
-------	---------------------------

Max. Output	Voltage	Weight
45 Amps	110 Volt	3 lbs.



*Note: Staples are made of a chromium alloy

• Welds Plastic without Staples
Welding cracks and filling holes. (Shark does not supply plastic rods.)

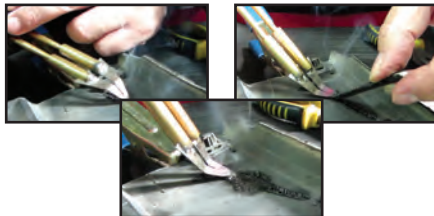

• Repairing Holes
Good for repairing different holes with stainless netting



• Tacking with Staples
Various staple configurations allow you to sew and seam all types of cracks.



STAINLESS STEEL MESH

Item#	Description	Pkg. Qty.
17044	12" x 12" Stainless Steel Mesh	1

• Heat Cutting
Easily cuts plastic tape, nylon strips, or rope.



• Lead-Tin Soldering
For quicker, higher efficiency than normal soldering guns or irons.



WELDING CARTS

MIG WELDING CART

MIG welding cart for easy storage and use of mig welders. Durable steel construction will give you years of use. Chain included with the cart for easy securing of gas bottles. Assembly required.

Features & Benefits:

- Solid steel construction
- Securing chains for gas bottles
- Two storage shelves

Item#	Description	Wt.
14483	11" Wide x 28" High x 28" Deep	30 lbs.



TANDEM CYLINDER TRUCK

16" Wide tandem cylinder truck is compact and useful in small aisles and crowded spaces. Designed for use with 2 cylinders, no greater than 8" diameter tanks. Made in USA. Cart Bed is 9" Wide x 17.5" Deep.

Features & Benefits:

- Narrow for use of maneuverability
- Fits (1) 80 to 150 cubic foot oxygen tank
- Fits (1) small or medium acetylene cylinder
- Cylinders load separately from front or rear
- Cylinders are secured with steel placement band for positive and safe containment

Item#	Description	Wt.
14477	10" Wheel	
14481	16" Wide x 42" High x 25" Deep	34 lbs.





WELDING CARTS

ECONOMICAL GAS CYLINDER HAND TRUCK

For standard and medium cylinders. Easy to use, lightweight truck fits most needs and will carry up to 122 cubic foot tanks. Made in USA. Cart bed is 8" x 16 3/4" - Large Tool Tray

Item#	Description	Wt.
14475	Axle	
14476	10" Wheel	
14480	21" Wide x 44" High x 14" Deep	30 lbs.



14480

HEAVY DUTY HAND TRUCK FOR LARGE CYLINDERS

Our heavy duty 18" rugged steel wheel truck moves easily over all surfaces. For use with Oxygen/Acetylene tanks. This is our work horse of carts, self-leveling tool shelf on back. Made in U.S.A. Cart bed is 12" x 24" - Large Tool Tray

Item#	Description	Wt.
14478	Axle	
14479	18" Wheel	
14482	34" Wide x 47" High x 22" Deep	60 lbs.



14482

WELDING HELMETS

POWERED AIR PURIFYING RESPIRATOR

Helmet with Powered Air Purifying Respirator
Item# 14250

Flame Retardant

Helmet is equipped with Expert Large Auto Darkening Lens
Item# 14269

ADF 800S Lens
(See page 99 for full lens specifications)



SPECIFICATIONS

Air Flow Rate

Low Speed: 170 litres/min
High Speed: 210 litres/min

Battery

Battery Type: Rechargeable Li-ion Battery
Battery Duration: 9 hours
Battery Life: 550 charges

Filter

Filter Efficiency: 99.97% of certain airborne contaminants, pollutants, fine particles, welding dust, and metal dust.



Alarms: Visible, Audible, and Vibrate

Operating Temperature: 23° to 131° F (-5 to 55° C)

Weight: 1.2 kg (2.65 lbs)
Standard: EN 12941 TH3

HOW TO OPERATE



-  Power on/off
Push and hold the Power Button for 3 Seconds.
-  Switch the airflow:
Push the Button to switch the airflow between 170 l/min and 210 l/min.
-  Warning lights help to check the filter status. The more lights turned on, the dirtier the filter. When the warning lights flash, replace the filter.

Item#	Operating Temperature	Weight	Battery Life	Standard	Air Flow Rate	Pkg. Qty
14250	23° to 131° F (-5° to 55° C)	2.6 lbs (1.2 kg)	550 Charges	EN 12941 TH3	170-210 litres/min	1
Item#	Description					Pkg. Qty
14251	Replacement Air Filter for 14250					1



AUTO-DARKENING HELMETS

OFFERED IN FIXED SHADE 10 OR 3 AUTO-DARKENING OPTIONS



The Shark Anniversary 9/11 Helmet

The Shark 9/11 Patriotic helmet gives you a chance to exhibit your patriotism. The helmet features the World Trade Towers, American Eagle and American Flag. Graphics are painted and not a decal.

Helmet includes:

- Lens options from fixed shade 10 to full auto-darkening. See details on page 98 and 99.
- Ratcheting Head Gear
- 4 Color Graphic Box
- Outside Cover Lens
- Inside Safety Lens

The Shark Red Racing Motif Helmet

The Shark Red Racing Helmet will put you ahead of the crowd! This exciting helmet is candy-apple red and features a checkered flag breaking through the sides. Graphics are painted and not a decal.

Helmet includes:

- Lens options from fixed shade 10 to full auto-darkening. See details on page 98 and 99.
- Ratcheting Head Gear
- 4 Color Graphic Box
- Outside Cover Lens
- Inside Safety Lens

The Shark Black Flame Motif Helmet

The Shark Black Flame Helmet featuring 3 dimensional chrome flames will make the old flames look out-dated! Grab this new approach on a favorite theme and claim it as yours. Graphics are painted and not a decal.

Helmet includes:

- Lens options from fixed shade 10 to full auto-darkening. See details on page 98 and 99.
- Ratcheting Head Gear
- 4 Color Graphic Box
- Outside Cover Lens
- Inside Safety Lens

Replacements for Above Helmets

Headgear	Item 14142	Page 134
Outside Cover Lenses	Item 14137	Page 102
Inside Safety lenses	Various	Page 102

HELMETS/LENS SPECIFICATIONS

Fixed Shade
Part# 14213
 (lens only)



Economy Auto-Darkening
Part# 14268
 ADF 810S
 (Lens only)



Part# 14262

Part# 14264

Part# 14266

Part# 14263

Part# 14265

Part# 14267

Features	Non Auto Darkening Shade 10	Good/Variable Auto Dark 9-13
Optical Class	----	1/1/1/2
Viewing Area	5.24"x4.49" (133x114mm)	3.82"x1.85" (97x47mm)
Size of Cartridge	5.24"x4.49" (133x114mm)	5.24"x4.50"x.35" (133x114x9mm)
Lens Shade	Shade 10	9-13 variable
Light State	----	Shade 3.5
Shade Control	----	Internal
Sensors	----	2
On/Off	----	Automatic
Power Supply	----	Solar cell, no battery change req.
Switch Time	----	1/25,000
Sensitivity Control	----	Adjust by infinity knob
Delay Time (Dark to Light)	----	0.35-0.45s
Grind Mode	----	Yes
Low TIG Amps Rated	----	>5 amps/DC; >5 amps/AC
Operating Temperature	-10°C - +55°C	-10°C - +55°C
Storing Temperature	-20°C - +70°C	-20°C - +70°C
Packing	4 Color Graphic Box	4 Color Graphic Box
Application Range	Stick Welding (DC&AC); Not for Grinding; Not for Laser Welding or Oxy Acetylene Welding/Cutting	Stick Welding (DC&AC); TIG(DC, DC Pulse); TIG AC(Pulse), Excellent low amperage TIG response, MIG/MAG; MIG/MAG Pulse; Plasma Cutting/Welding; Grinding; Not for Laser Welding or Oxy Acetylene Welding/Cutting
Standard	ANSI Z87.1, CSA Z94.3 Approved	ANSI Z87.1, CSA Z94.3 Approved

(Continued)



HELMETS/LENS SPECIFICATIONS

Expert Large Auto-Darkening

Part# 14269

ADF 800S
(Lens only)



Expert Pro Auto-Darkening

Part# 14270

ADF 820S
(Lens only)



Part#
14252

Part#
14254

Part#
14256

Part#
14253

Part#
14255

Part#
14257

Features	Better/Variable Expert Large Auto View Dark	Best/Variable Expert Pro Full View Auto Dark
Optical Class	1/1/1/2	1/2/1/1
Viewing Area	3.82"x1.85" (97x47mm)	3.82"x2.44" (97x62mm)
Size of Cartridge	5.24"x4.50"x.35" (133x114x9mm)	5.24"x4.50"x.35" (133x114x9mm)
Lens Shade	9-13 variable	9-13 variable
Light State	Shade 3.5	Shade 3.5
Shade Control	Internal	Internal
Sensors	2	4
On/Off	Automatic	Automatic
Power Supply	Solar cell+Battery Replacable	Solar cell+Battery Replacable
Switch Time	1/25,000	1/25,000
Sensitivity Control	Adjust by infinity dial knob	Adjust by infinity dial knob
Delay Time (Dark to Light)	0.1-1.0s by infinity dial control knob	0.1-1.0s by infinity dial control knob
Grind Mode	Yes	Yes
Low TIG Amps Rated	>2 amps/DC; >2 amps/AC	>2 amps/DC; >2 amps/AC
Operating Temperature	-10°C - +55°C	-10°C - +100°C
Storing Temperature	-20°C - +70°C	-20°C - +100°C
Packing	4 Color Graphic Box	4 Color Graphic Box
Application Range	Stick Welding (DC&AC); TIG(DC, DC Pulse); TIG AC(Pulse), Excellent low amperage TIG response , MIG/MAG; MIG/MAG Pulse; Plasma Cutting/Welding; Grinding; Oxy Acetylene Welding/Cutting; Not for Laser Welding.	Stick Welding (DC&AC); TIG(DC, DC Pulse); TIG AC(Pulse), Excellent low amperage TIG response , MIG/MAG; MIG/MAG Pulse; Plasma Cutting/Welding; Grinding; Not for Laser Welding or Oxy Acetylene Welding/Cutting
Standard	ANSI Z87.1, CSA Z94.3 Approved	ANSI Z87.1, CSA Z94.3 Approved

WELDING HELMETS

BLUE/RED NYLON LIFT FRONT HELMETS

Helmets are available in 2 lens sizes - shade 10 - with a clear plastic cover lens. Ratchet type headgear with a flip-up lens so helmet does not need to be removed or raised while viewing work. Helmets ship in graphic boxes.

Item#	Style	Headgear	Lens Size	Color
14107	Lift Front	Ratchet	2" x 4 1/4"	Blue
14106	Lift Front	Ratchet	4" 1/2" x 5 1/4"	Blue
14272	Lift Front	Ratchet	4" 1/2" x 5 1/4"	Red



14272



14107





WELDING HELMETS

ECONOMY WELDING HELMETS

These helmets are our most economical style, and include a shade 10 lens and ratcheting headgear.

Item#	Style	Head Gear	Lens Size	Description
14109	Fixed Front	Ratchet	2" x 5 1/4"	Black Nylon Helmet
14114	Fixed Front	Ratchet	2" x 4 1/4"	Black Nylon Helmet
14116	Lift Front	Ratchet	2" x 4 1/4"	Black Polypropelene Helmet



14114



14116

SILVER COATED, COOL LIFT FRONT WELDING HELMET

This lift front helmet has a 2" x 4 1/4" lens. 30% cooler than uncoated helmets, it comes with a ratcheting headgear and shade 10 lens. Meets ANSI standards.

Item#	Style	Head Gear	Lens Size	Color
14112	Lift Front	Ratchet	2" x 4 1/4"	Silver



14112

WELDING LENSES

CLEAR REPLACEMENT COVER LENSES



REPLACEMENT INSIDE COVER LENS FOR AUTO-DARKENING FILTERS

Item#	Description	Size	Pkg. Qty.
14275	ADF810S & ADF600S	2" x 3 3/4"	1
14277	AF200A	1 3/4" x 3 3/4"	1
14340	ADF800S	2 1/2" x 3 3/4"	1
14341	ADF820S	3 1/2" x 3 3/4"	1



REPLACEMENT FRONT COVER LENS FOR AUTO-DARKENING HELMETS

Item#	Description	Size	Pkg. Qty.
14137	ADF800S / ADF810S / ADF820S	5 1/4" x 4 1/2"	1
14135	ADF600S	4 1/4" x 4 5/8"	1
14274	AF200A	3 5/8" x 4 3/8"	1

*To find the appropriate ADF/AF#, look on the inside of the auto-darkening lens housing.



WELDING LENSES

These lenses provide maximum protection from ultraviolet and infrared radiation. The darker lenses are for higher amperage, where the lighter lenses are for indoor and light welding. Clear cover lenses are made of high quality material to protect shaded lenses, where gold lenses reflect radiated energy from arcs.

Sizes 2" x 4 1/4"

Item#	Size	Shade	Pkg. Qty
14200	2" x 4 1/4"	#5 Glass	1
14201	2" x 4 1/4"	#8 Glass	1
14202	2" x 4 1/4"	#9 Glass	1
14203	2" x 4 1/4"	#10 Glass	1
14204	2" x 4 1/4"	#11 Glass	1
14205	2" x 4 1/4"	#12 Glass	1
14206	2" x 4 1/4"	Clear Polycarbonate	1
14207	2" x 4 1/4"	Clear Polycarbonate	1
14208	2" x 4 1/4"	Clear Glass	1
14209	2" x 4 1/4"	Gold #9 Glass	1
14210	2" x 4 1/4"	Gold #10 Glass	1

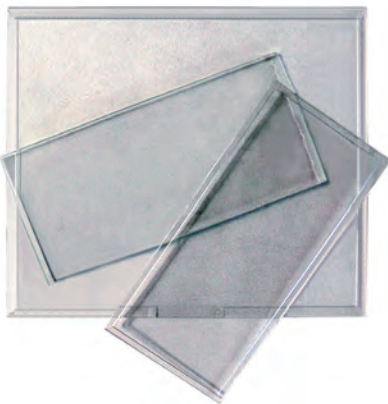

Sizes 4 1/2" x 5 1/4"

Item#	Size	Shade	Pkg. Qty
14211	4 1/2" x 5 1/4"	#8 Glass	1
14212	4 1/2" x 5 1/4"	#9 Glass	1
14213	4 1/2" x 5 1/4"	#10 Glass	1
14214	4 1/2" x 5 1/4"	#11 Glass	1
14215	4 1/2" x 5 1/4"	#12 Glass	1
14216	4 1/2" x 5 1/4"	Polycarbonate	1
14217	4 1/2" x 5 1/4"	Clear Glass	1
14218	4 1/2" x 5 1/4"	Gold #9 Glass	1
14219	4 1/2" x 5 1/4"	Gold #10 Glass	1

50MM ROUND LENSES

These high quality lenses are 50 millimeters in diameter and are sold in pairs.



Item#	Shade	Pkg. Qty.
14220	Green Shade #4-Poly	1 Pair
14221	Green Shade #5-Poly	1 Pair
14222	Green Shade #6-Poly	1 Pair
14223	Clear Glass	1 Pair
14224	Clear Polycarbonate Cover	1 Pair



14225/14226

Item#	Size	Magnification	Pkg. Qty.
14225	2" x 4 1/4"	F 1.50	1
14226	2" x 4 1/4"	F 2.00	1



Material	Shielding Gas	Wire	Output Polarity
Steel	80% Helium 20% Argon 2.5% CO ₂	DCSP	DCP
Aluminum	Argon	DCSP	DCP

OUTPUT POLARITY



5 6 7 8 9 10
WIRE FEED

5 6 7 8 9 10
MIG

MODEL	SW-MIG 140	N°	17024
			EN 60974 - 1
			30 A - 140 A
		X	30%
		I ₁	21 A
		I ₂	90 A
		U ₂	18 V
		U ₀	78 V
		U ₁	120 V
		I _{max}	21 A
		I _{eff}	11.5 A

IF CONNECTED TO A CIRCUIT PROTECTED BY FUSES, USE TIME DELAY FUSE MARKED D

SW-MIG 140
WIRE FEED WELDER
Made in China

WIRE FEED WELDER



SHARK INDUSTRIES

Rod & Wire

- ▶ Welding Electrodes
- ▶ Mig Wires
- ▶ Storage Tubes
- ▶ Solders





ROD & WIRE

6010 WELDING ELECTRODE

This all position, mild steel rod provides smoother arc characteristics. Used for out of position welding, maintenance welding, galvanized steel, ship building and pipe line welding.



11004

Item#	Size	Rec Amperage	Pkg. Qty.
11000	3/32"	60-85	1 lb.
11001	3/32"	60-85	5 lb.
11002	3/32"	60-85	10 lb.
11003	1/8"	65-120	1 lb.
11004	1/8"	65-120	5 lb.
11005	1/8"	65-120	10 lb.
11006	5/32"	110-170	1 lb.
11007	5/32"	110-170	5 lb.
11008	5/32"	110-170	10 lb.

6011 WELDING ELECTRODE

This all position, all purpose, mild steel electrode has strong arc characteristics for deep penetration.

Used for tanks, steel castings, machinery parts, construction and pressure pipe.



11014

Item#	Size	Rec Amperage	Pkg. Qty.
11009	3/32"	40-80	1 lb.
11010	3/32"	40-80	5 lb.
11011	3/32"	40-80	10 lb.
11012	3/32"	40-80	50 lb.
11013	3/32"	40-80	4 Rods
11014	1/8"	75-120	1 lb.
11015	1/8"	75-120	5 lb.
11016	1/8"	75-120	10 lb.
11017	1/8"	75-120	50 lb.
11018	1/8"	75-120	3 Rods
11019	5/32"	110-170	1 lb.
11020	5/32"	110-170	5 lb.
11021	5/32"	110-170	10 lb.
11022	5/32"	110-170	50 lb.
11023	5/32"	110-170	3 Rods

6013 WELDING ELECTRODE

This all position, all purpose, mild steel electrode has a stable arc designed for welding on clean, new metal.

Used for general purpose welding, build-up of shafts and machine parts.



11034

Item#	Size	Rec Amperage	Pkg. Qty.
11024	3/32"	50-100	1 lb.
11025	3/32"	50-100	5 lb.
11026	3/32"	50-100	10 lb.
11027	3/32"	50-100	50 lb.
11028	3/32"	50-100	4 Rods
11029	1/8"	80-130	1 lb.
11030	1/8"	80-130	5 lb.
11031	1/8"	80-130	10 lb.
11032	1/8"	80-130	50 lb.
11033	1/8"	80-130	3 Rods
11034	5/32"	105-180	1 lb.
11035	5/32"	105-180	5 lb.
11036	5/32"	105-180	10 lb.
11037	5/32"	105-180	50 lb.
11038	5/32"	105-180	3 Rods

ROD & WIRE

E7014 WELDING ELECTRODE

This all position, mild steel iron powder type electrode has smooth arc characteristics for medium penetration.

Used for tanks, steel castings, machinery parts, construction and pressure pipe. Works best on clean steel applications.



11040

E7018 WELDING ELECTRODE

This all position, low hydrogen electrode provides high strength and toughness without cracking down the center of the bead. For use on high carbon and cold rolled steel. Joins hard to weld steels easily.



11055

Item#	Size	Rec Amperage	Pkg. Qty.
11054	3/32"	55-85	1 lb.
11055	3/32"	55-85	5 lb.
11056	3/32"	55-85	10 lb.
11057	3/32"	55-85	50 lb.
11058	3/32"	55-85	4 Rods
11059	1/8"	90-140	1 lb.
11060	1/8"	90-140	5 lb.
11061	1/8"	90-140	10 lb.
11062	1/8"	90-140	50 lb.
11063	1/8"	90-140	3 Rods
11064	5/32"	110-185	1 lb.
11065	5/32"	110-185	5 lb.
11066	5/32"	110-185	10 lb.
11067	5/32"	110-185	50 lb.
11083	5/32"	110-185	3 Rods
11132	3/16"	110-185	50 lb.

Item#	Size	Rec Amperage	Pkg. Qty.
11039	3/32"	50-100	1 lb.
11040	3/32"	50-100	5 lb.
11041	3/32"	50-100	10 lb.
11042	3/32"	50-100	50 lb.
11043	3/32"	50-100	4 Rods
11044	1/8"	90-140	1 lb.
11045	1/8"	90-140	5 lb.
11046	1/8"	90-140	10 lb.
11047	1/8"	90-140	50 lb.
11048	1/8"	90-140	3 Rods
11049	5/32"	140-210	1 lb.
11050	5/32"	140-210	5 lb.
11051	5/32"	140-210	10 lb.
11052	5/32"	140-210	50 lb.
11053	5/32"	140-210	3 Rods

E7018 AC WELDING ELECTRODE

All position rod for AC or DC reverse polarity current.



11073

Item#	Size	Rec Amperage	Pkg. Qty.
11068	3/32"	55-85	1 lb.
11069	3/32"	55-85	5 lb.
11070	3/32"	55-85	10 lb.
11071	3/32"	55-85	50 lb.
11072	3/32"	55-85	4 Rods
11073	1/8"	90-140	1 lb.
11074	1/8"	90-140	5 lb.
11075	1/8"	90-140	10 lb.
11076	1/8"	90-140	50 lb.
11077	1/8"	90-140	3 Rods
11078	5/32"	130-185	1 lb.
11079	5/32"	130-185	5 lb.
11080	5/32"	130-185	10 lb.
11081	5/32"	130-185	50 lb.
11082	5/32"	130-185	3 Rods



ROD & WIRE



11094



11085

HARDFACING WELDING ELECTRODES

High quality, graphite coated, hardfacing material, produces outstanding impact and abrasion resistance. This all position, AC or DC rod is designed to run at low temperature (53 to 57 "C").

Ideal for repairing all types of agriculture, construction equipment and concrete mixers.

Item#	Size	Rec Amperage	Pkg. Qty.
11094	1/8" x 14"	80-125	1 lb.
11095	1/8" x 14"	80-125	5 lb.
11096	1/8" x 14"	80-125	3 Rods



11089



11092

99% NICKEL CAST IRON ELECTRODES

The highest quality nickel electrode available. The high nickel content has a natural attraction to cast iron, giving it superior performance when welding cast iron material. No preheating or post-heating. For machinable welds.

Used for engine blocks, surface build up, cracked castings, cylinder heads and exhaust manifolds.

Item#	Size	Rec Amperage	Pkg. Qty.
11088	1/8"	100-135	1 lb.
11089	1/8"	100-135	5 lb.
11090	1/8"	100-135	3 Rods

NOMACAST ELECTRODES

Made from mild steel-nickel alloy. Not machinable.

Used for welding cast iron and great for use on parts that do not expand from heat.

Item#	Size	Rec Amperage	Pkg. Qty.
11085	1/8"	70-105	1 lb.
11086	1/8"	70-105	5 lb.
11087	1/8"	70-105	3 Rods

55% NICKEL CAST IRON ELECTRODE

The most versatile cast iron electrode, nickel wire designed for making non-machinable welds in cast iron. Welds well on dirty or corroded surfaces with a smooth arc at low amperages.

Used for repairing cylinder blocks, exhaust manifolds and machine bases.

Item#	Size	Rec Amperage	Pkg. Qty.
11091	1/8" x 14"	100-135	1 lb.
11092	1/8" x 14"	100-135	5 lb.
11093	1/8" x 14"	100-135	3 Rods

ROD & WIRE



11097

ER 4043 ALUMINUM ELECTRODES

Flux coated aluminum electrode used for alloy and aluminum welding. Applications include: castings, plates, aluminum, sheet metal, piping and tanks. For flat horizontal and vertical welding.

Item#	Size	Rec Amperage	Pkg. Qty.
11097	1/8"	70-120	1 lb.
11098	1/8"	70-120	5 lb.
11099	1/8"	70-120	3 Rods



11101

BARE BRAZING RODS

Made from a balance of zinc and copper alloy. These high quality, low fuming rods tin easily and offer great wear resistance. Brazing flux required. Good for brazing fenders, radiators, sheet metal and water tanks.

Item#	Size	Pkg. Qty.
11101	3/32" x 36" Long	1 lb.
11102	1/8" x 36" Long	1 lb.
11122	3/32" x 18" Long Job Pk.	4 Rods
11123	1/8" x 18" Long Job Pk.	3 Rods



11109

ER 5356 BARE ALUMINUM RODS

Used for aluminum repair. For use with torch and aluminum flux.

Item#	Size	Pkg. Qty.
11109	3/32" x 36" Long	1 lb.
11110	1/8" x 36" Long	1 lb.
11124	3/32" x 18" Long Job Pack	4 Rods
11125	1/8" x 18" Long Job Pack	3 Rods



11107

FLUX COATED BRAZING RODS

This flux coated, low fuming brazing rod is strong and wear resistant. High quality and easy to tin, fuses well with cast iron, galvanized iron, steel, brass and copper. Good for use on autos, tanks and pipes.

Item#	Size	Pkg. Qty.
11107	3/32" x 36" Long	1 lb.
11108	1/8" x 36" Long	1 lb.
11127	1/8" x 18" Long Job Pack	3 Rods



ROD & WIRE



11103

HARDFACING ELECTRODE

Alloy produces long wear and a mirror finish when polished. High abrasion resistance with moderate impact. Bonds easily. Great for thin wear edges on farm implements.

Item#	Size	Pkg. Qty.
11103	3/16" x 14" Long	1 lb.
11128	3/16" x 18" Long	2 Rods



11100

SUPER SIL-FLO

Self fluxing on copper. Substitute for 6% to 15% silver content brazing alloys for copper installations. Not recommended for iron or steel. Applications include: joints, couplings, pipe and copper tubing extensions and copper and brass control valves.

Item#	Size	Rec. Amperage	Pkg. Qty.
11100	1/8" x 20"	75-130	1/2 lb.
11121	1/8" x 20" Job Pk.	75-130	2 Rods



12050

STORAGE TUBE

Partitioned plastic storage tube allows you to keep 4 different types of electrodes in one container. Tight seal gasket prevents moisture from penetrating the rod. 14" maximum rod length. Convenient built-in belt hook.

Item#	Size	Pkg. Qty.
12050	15" x 3 1/4"	1



11104

RG45 OXY - ACETYLENE RODS

Copper coating prevents rusting and improves corrosion resistance. An excellent all purpose rod for use in shops, home, maintenance and commercial.

Item#	Size	Pkg. Qty.
11104	1/16" x 36" Long	1 lb.
11105	3/32" x 36" Long	1 lb.
11106	1/8" x 36" Long	1 lb.



11118

E308L-16 SUPER 3 STAINLESS STEEL RODS

All position, high strength chromium and nickel alloy electrode. Corrosion resistant in high and low temperatures.

Crack resistant even on high carbon, manganese, stainless and dissimilar steels.

Item#	Size	Rec. Amperage	Pkg. Qty.
11112	1/16"	25-35	1 lb.
11113	1/16"	25-35	5 lb.
11114	1/16"	25-35	4 Rods
11115	3/32"	50-70	1 lb.
11116	3/32"	50-70	5 lb.
11117	3/32"	50-70	4 Rods
11118	1/8"	75-100	1 lb.
11119	1/8"	75-100	5 lb.
11120	1/8"	75-100	3 Rods

ROD & WIRE

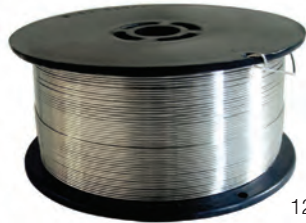

12011

ALUMINUM MIG WIRE - ER 5356

Excellent for all types of aluminum welding. Made from premium aluminum. For use with aluminum alloys using MIG and TIG welding processes.

Item#	Wire Type	Wire Size	Spool Sz.	Pkg. Qty
12011	Aluminum	.030	1 lb.	1
12012	Aluminum	.035	1 lb.	1
12061	Aluminum	.030	16 lb.	1
12062	Aluminum	.035	16 lb.	1

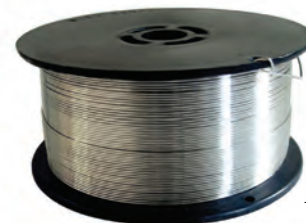

12042

ALUMINUM MIG WIRE - ER 4043

Made from premium aluminum. For use with aluminum alloys using MIG and TIG welding processes. Excellent for all types of aluminum welding.

Item#	Wire Type	Wire Size	Spool Sz.	Pkg. Qty
12042	Aluminum	.030	1 lb.	1
12043	Aluminum	.035	1 lb.	1
12063	Aluminum	.030	16 lb.	1
12064	Aluminum	.035	16 lb.	1

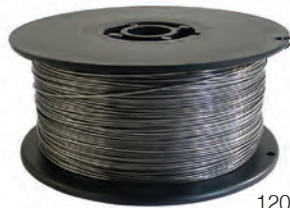

12008

GASLESS FLUX CORED MIG WIRE (E 71T-GS)

This flux-cored steel wire is used without gas as a shielding agent on migwelders with reverse polarity. Produces a deep penetrating weld.

Item#	Wire Type	Wire Size	Spool Sz.	Pkg. Qty
12008	Flux-cored/Steel	.030	2 lb.	1
12021	Flux-cored/Steel	.030	10 lb.	1
12009	Flux-cored/Steel	.035	2 lb.	1
12010	Flux-cored/Steel	.035	10 lb.	1



12000

MILD STEEL MIG WIRE (ER70S-6)

Made from a premium mild steel, this wire has powerful deoxidizers for surface cleaning. Used for automobile repair, truck bodies, tanks, fabrication and construction jobs, Shielding gas required.

Item#	Wire Type	Wire Size	Spool Sz.	Pkg. Qty
12000	Steel	.023	2 lb.	1
12001	Steel	.023	11 lb.	1
12051	Steel	.023	33 lb.	1
12002	Steel	.030	2 lb.	1
12003	Steel	.030	11 lb.	1
12004	Steel	.030	33 lb.	1
12005	Steel	.035	2 lb.	1
12006	Steel	.035	11 lb.	1
12007	Steel	.035	33 lb.	1
12052	Steel	.035	44 lb.	1

STAINLESS MIG WIRE - ER308L

Made from premium stainless steel. Designed for horizontal and vertical welding. Use with 100% Argon/Shielding gas or 75% Argon/25% CO2. Excellent for the food and beverage industry, fabrication, tanker trucks and general maintenance and repair.

Item#	Wire Type	Wire Size	Spool Sz.	Pkg. Qty
12013	Stainless Steel	.030	2 lb.	1
12014	Stainless Steel	.035	2 lb.	1



12013



SOLDER

ACID FLUX CORE SOLDER

Best used for non-electrical applications such as sheet metal joint and fitting connections. 3.3 Tin - 2.2 Antimony - 95.5 lead

Item#	Size	Grade	Tensile Strength	Melting Temp	Wt.
12024	1/8"	40/60% Tin-Lead	4900	460° F	1/4 lb.
12025	1/8"	Commercial	4900	575° F	1 lb.



12024

LEAD FREE WIRE SOLDER

100% Lead Free - 95% tin and 5% antimony alloy. Complies with federal and state laws prohibiting lead in water systems. Used for non-electrical applications such as: refrigeration and plumbing system repairs.

Item#	Size	Grade	Tensile Strength	Melting Temp	Wt.
12015	1/8"	95/5% Tin-Ant	6000	464° F	1 lb.
12016	1/8"	95/5% Tin-Ant	6000	464° F	1/2 lb.
12017	1/8"	95/5% Tin-Ant	6000	464° F	1/4 lb.
12018	3/32"	95/5% Tin-Ant	6000	464° F	1/4 lb.
12019	3/32"	95/5% Tin-Ant	6000	464° F	1/2 lb.
12020	3/32"	95/5% Tin-Ant	6000	464° F	1 lb.



12015

ROSIN FLUX CORE SOLDER

Flux is a mild cleaning agent, but it is completely non-corrosive and electrically non-conductive. Works well on all types of electrical connections.

Item#	Size	Grade	Tensile Strength	Melting Temp	Wt.
12026	1/16"	60/40% Tin-Lead	7600	460° F	1/4 lb.
12027	3/32"	40/60% Tin-Lead	5400	460° F	1/4 lb.
12028	3/32"	30/70% Tin-Lead	5400	491° F	1/2 lb.
12029	1/8"	Commercial	3600	575° F	1 lb.



12026

SOLID WIRE SOLDER

This solder must be used with paste or liquid flux. Used for general, non-electrical applications such as: radiator repairs and other general jobs.

Item#	Size	Grade	Tensile Strength	Melting Temp	Wt.
12031	1/8"	30/70% Tin-Lead	4500	491° F	1/2 lb.
12032	1/8"	40/60% Tin-Lead	4900	460° F	1/4 lb.
12033	1/8"	50/50% Tin-Lead	5500	413° F	1/2 lb.
12034	3/32"	50/50% Tin-Lead	5500	421° F	1/4 lb.
12035	3/32"	40/60% Tin-Lead	4900	460° F	1/4 lb.



12031

SOLDER

PASTE FLUX

A general purpose cleaning/bonding agent for soldering jobs.

Item#	Size	Pkg. Qty.
12038	2 oz.	1



12038

BRAZING FLUX

General purpose brazing flux for stronger bond.

Item#	Size	Pkg. Qty.
12040	1/2 lb. - Dry Brazing Flux	1
12041	1 lb. - Dry Brazing Flux	1



12040

SILVER SOLDER

Lead free (non-toxic) metal only. Stored in pin pack to keep solder roll neat. For use with chrome plate, brass, nickel, copper and stainless steel. PSI: 8000.

Item#	Size	Description	Pkg. Qty.
12036	.50 oz.	3/64" Diameter	1
12037	4 oz. bottle of Flux	1050°-1600° F Melting Temperature	1



12036



SHARK INDUSTRIES

Accessories

- ▶ Anti-Spatter
- ▶ Electrode Holders
- ▶ Ground Clamps
- ▶ Chipping Hammers
- ▶ Soapstone
- ▶ Tip Cleaners
- ▶ Clamps
- ▶ Plugs & Receptacles
- ▶ Cable Lugs
- ▶ Tank Adaptors
- ▶ Hose, Splicers and Connectors
- ▶ Lighters
- ▶ Magnets
- ▶ Gauges





PIPE TEMPLATE/GEL/SPRAY/COLD FIRE

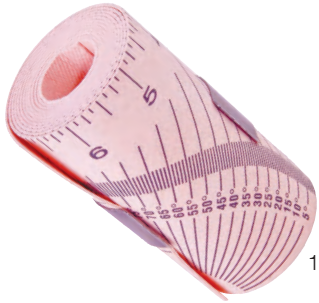

12248



12295

WRAP-AROUND PIPE TEMPLATE

This pipe template is made of a tough, flexible material with a protractor, scale and 45 degree angle markings. Used by all layout men, fitters and welders.

Item#	Dimensions	Wt.	Pkg. Qty.
12248	4" x 60"	.4 lb.	1

COLD FIRE WELDING SURFACE PROTECTANT

Puts out flames and cools hot surfaces in heat sensitive welding applications. Cold Fire is an excellent aerosol spray that instantly cools hot surfaces. It is environmentally safe, used by welders, plumbers and homeowners alike. Used in plumbing applications to pre-spray an area before soldering to help prevent heat damage or reduce hidden fire risks.

Item#	Description	Pkg. Qty.
12295	12 oz. Aerosol Spray	1



12253

12254

ANTI-SPATTER SPRAY AND NOZZLE GEL

Anti-Spatter Spray: Environmentally safe spray reduces welding spatter. Made of non-toxic ingredients.

Nozzle Gel: Provides excellent protection against weld spatter build-up on MIG gun nozzles, contact tips, positioners, stud welding chucks and electrode holders. Can be used on all automatic and semi-automatic welding apparatus. Will not cause porosity.

All Water Based, Biodegradable materials

Item#	Description	Pkg. Qty.
12253	Nozzle Gel	1
12254	Anti-Spatter Spray	1



12296

COLD FIRE WELDING SURFACE PROTECTANT

This 32 oz. aerosol pump is excellent as a spot fire extinguisher for Class A, B and D (metal) fires. Saves time in welding process. Helps eliminate disassembly of parts where heat damage is an issue. Used for the same applications as the 12 oz. aerosol spray only in a larger size pump.

Item#	Description	Pkg. Qty.
12296	32 oz. pump	1

CABLE CUTTERS/CONNECTORS/CLAMPS



12230

CABLE

Exceptional abrasive resistance with maximum flexibility. Yellow safety liner for added protection.

Item#	Amps/Length Rating	Size	Gauge
12230	100 amps up to 75'	100' Box	4
12231	150 amps up to 100'	100' Box	2
12232	100 amps up to 125'	100' Box	1
12233	150 amps up to 125'	100' Box	1/0
12298	Battery and Automotive Cable – 105 Amps	100' Box	6



12234

CABLE CUTTER

Heavy duty shears for cutting through cable and rubber hose. Designed for copper or aluminum cable.

Item#	Dimensions	Wt.	Pkg. Qty.
12234	10 1/2" x 2"	1.1 lb.	1

CONNECTORS

Cable Connector Sets

Fits cable sizes 6 - 2, Male and Female.

Heavy duty brass construction, locking cam-type connectors are used for light or heavy duty connecting applications, such as replacing old connectors or joining cables without soldering.

Item#	Size	Range	Pkg. Qty.
12226	#4 - 1/0	300A-400A	1 Set
12227	#1/0 - 2/0	400A-500A	1 Set



12104

BATTERY CLAMPS

Heavy gauged steel, battery charger clamps are used up to 400 Amps. They come equipped with cable lug- one red and one black with insulated handles.

Item#	Dimensions	Wt.	Pkg. Qty.
12104	1 1/4" x 6"	1 lb.	1 Pair



12226



ELECTRODE HOLDERS/CLAMPS



12101

ELECTRODE HOLDER

These heat resistant, light weight holders have fiberglass handles and jaws. Highly conductive copper tongs are insulated for safe operation.

Item#	Amperage	Pkg. Qty.
12100	200	1
12101	300	1
12102	500	1



12103

STUB TYPE ELECTRODE HOLDER

This holder has jaws that lock onto the rod with a one quarter turn of the handle.

Item#	Amperage	Pkg. Qty.
12103	400	1



12106

STEEL GROUND CLAMPS

Steel clamp is used for cable sizes to 2/0. The connection is made right to the wide grip jaws.

Item#	Type	Amperage	Pkg. Qty.
12105	Steel	200	1
12106	Steel	300	1
12107	Steel	500	1



BRASS GROUND CLAMPS

Brass Clamp is highly conductive and has a broad base for sliding under flat, heavy work.

Item#	Type	Amperage	Pkg. Qty.
12108	Brass	200-300	1
12109	Brass	300-400	1



12113

HEAVY DUTY COPPER GROUND CLAMP

This copper jaw clamp has a long-life rear spring and wide Jaw for versatile positioning and positive grounding.

Item#	Type	Amperage	Pkg. Qty.
12113	Copper Alloy Jaws	300-500	1

CHIPPING HAMMERS/SOAPSTONE & HOLDER

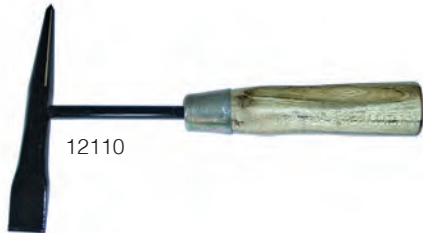

WOODEN HANDLE CHIPPING HAMMER

Wooden handle straight head hammer used for cleaning slag off metal.

Item#	Type	Pkg. Qty.
12110	Straight Head Chipping Hammer	1



SPRING HANDLE CHIPPING HAMMER

Metal spring handle with cross chisel hammer has a head the opposite of the straight head.

Item#	Type	Pkg. Qty.
12111	Cross Chisel Chipping Hammer	1

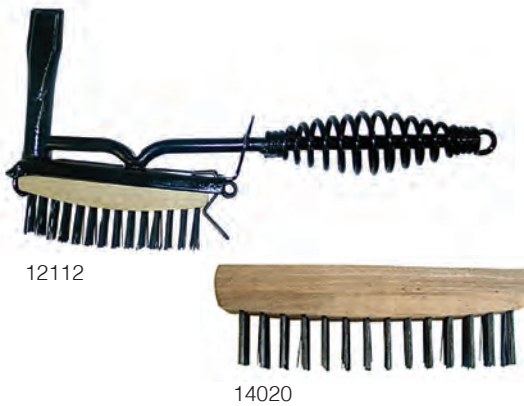

WIRE BRUSH AND CHIPPING HAMMER

Chipping hammer with a detachable wire brush offers quick slag removal and weld cleaning. Replaceable brush.

Item#	Type	Pkg. Qty.
12112	Chipping Hammer w/Wire Brush	1
14020	Replaceable Wire Brush 4 3/4" Long x 3/4" Wide	1



SOAPSTONE AND SOAPSTONE HOLDERS

Choose from our Round or Flat holders.

Item#	Type	Size	Pkg. Qty.
12211	Round Holder	3/8" x 4 3/4"	1
12212	Round Refill	1/4" x 5"	10
12213	Bulk Round Refill	1/4" x 5"	144
12214	Flat Holder	5/8" x 5 1/2"	1
12215	Flat Refill	3/16" x 1/2" x 5"	10
12216	Bulk Flat Refill	3/16" x 1/2" x 5"	144



TIP CLEANER/DRILL SET/DEBURRING TOOL/PENCIL/LIGHTERS



OXY-ACETYLENE TIP CLEANERS

Both types are easy to use. Kit features circle design to provide 60 cleaning edges per inch. Kit includes file which fits all tip sizes. Long cleaner has longer files for hard to reach areas. Recommended for heavy duty cutting attachments.

Item#	Style	Dimensions	Pkg. Qty.
12241	Regular Cleaner	3 1/2" x 3 9/16"	1
12242	Long Cleaner	4" x 3 13/16"	1



DEBURRING TOOL

Tool has a heat treated, tempered steel cutting edge that swivels to ensure a good cutting action. Used to debur metal and plastic pipe.

Item#	Size	Pkg. Qty.
12210	5"	1



TIP DRILL SET

This pencil type holder has 12 drills inside. Comes with a pocket clip. Cleans and trues acetylene cutting and welding orifices. (.5 through 1.5mm)

Item#	Type	Pkg. Qty.
12243	Tip Drill Set	1
12244	Replacement Tip Drills	1

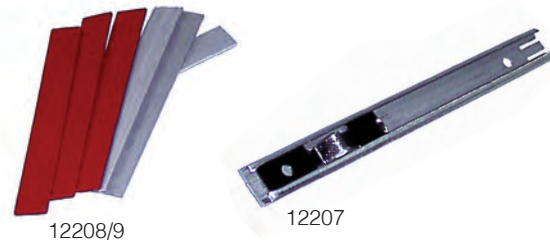

MARKING PENCIL

This thin line pencil resists breakage and requires no sharpening.

Item#	Description	Pkg. Qty.
12207	Marking Pencil - with 3 silver, 3 red refills	1
12208	Refill - Silver	6
12209	Refill - Red	6

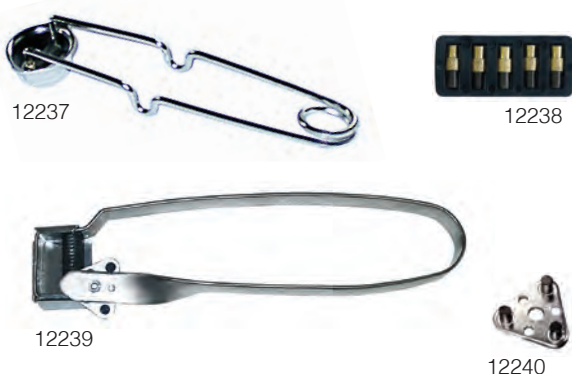

OXY-ACETYLENE LIGHTERS

The one flint lighter is lightweight, dependable and has a large round file and hood. This is the most popular in the welding industry.

The three flint lighter has a round file with three large flints and a bright plated finish. Rotate new flint into position when used flint is worn out.

Item#	Type	Pkg. Qty.
12237	1 Flint Oxy - Acetylene Lighter	1
12238	Single Striker Replacement Flints	5
12239	3 Flint Oxy - Acetylene Lighter	1
12240	Triple Striker Replacement Flints	1

CLAMPS

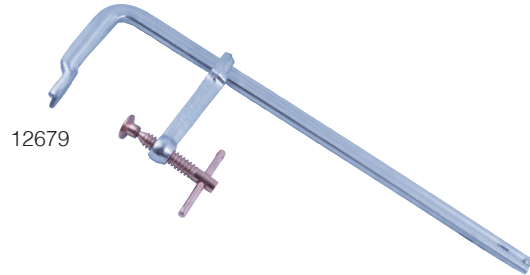

C - CLAMPS

Clamps are made with a high tensile frame and copper plated steel screws. The handle has a sliding pin and a rocking pad at the screw end.

Item#	Size	Pkg. Qty.
12217	2"	1
12218	3"	1
12219	4"	1
12220	5"	1
12221	6"	1
12673	8"	1
12674	10"	1
12675	12"	1

F - CLAMPS

The "F" Clamp has a very rapid set up time. It is 90% faster than "C" Clamps. Made from drop forged, heat treated, plated steel with a screw and handle that are copper coated to protect against weld spatter.

Item#	Size	Pkg. Qty.
12676	8"	1
12677	10"	1
12678	12"	1
12679	16"	1



12222

LOCKING C - CLAMP

Holds work tightly where you want it, allowing room to work around large pieces.

Item#	Size	Pkg. Qty.
12222	10 1/2" long	1



12223

LOCKING WELDING CLAMP

Made of plated steel, this is the most secure method of holding two pieces of metal together for welding. Can be adjusted to different thicknesses.

Item#	Size	Pkg. Qty.
12223	Locking Welding Clamp	1



LIGHTER/MAGNETS/PICKS/SCRIBES



12245

LIGHTNIN' BUG TORCH LIGHTER

Electrically generates a spark. Tested to 30,000 strikes this patented lighter ignites all fuel gases quickly and easily, again and again. Well worth the investment as it never needs replacement flints.

Corrosion and rust resistant.

Item#	Description	Pkg. Qty.
12245	Skin Packaged Lightnin' Bug	1



12202

SCRIBES

Premium scribe has a sharp tungsten carbide tip which leaves clear markings on metal, plastic, glass and tools. Comes with a replaceable tip and pocket clip.

Item#	Description	Pkg. Qty.
12202	Premium Scribe	1



12250

MULTI-PURPOSE MAGNETS

These magnets have an anisotropic ferrite magnet and a steel plate finish. Designed to hold ferrous metals at 45, 90 and 135 degree angles.

Used for welding, soldering, assembly, pipe installation and holding of metal parts while welding.

Item#	Size	Net. Wt.	Supports	Direct	Qty.
12250	2" x 2 1/2" x 1/2"	0.50	30 lbs.	20 lbs.	1
12251	2 3/4" x 3 1/4" x 9/16"	0.75	45 lbs.	33 lbs.	1
12252	3 5/8" x 4 1/16" x 3/4"	1.65	80 lbs.	55 lbs.	1



12201

4 WAY PICK KIT

This four way repair kit has a knurled aluminum handle with four tempered steel picks. Comes in a plastic pouch.

Item#	Description	Pkg. Qty.
12201	Repair Pick Kit	1



12206

12205

MAGNET & MIRROR WITH FLEXIBLE HANDLE

The 17" long magnet can reach into tight places for ferrous metal objects. The mirror allows quick, clear inspection of obscure areas and can swivel 360 degrees. Plastic break resistant mirror.

Item#	Description	Pkg. Qty.
12205	Magnet with Flexible Handle / USA	1
12206	Mirror with Flexible Handle / USA	1

PLIERS/LEVEL/KNIFE/RECEPTACLES & PLUGS

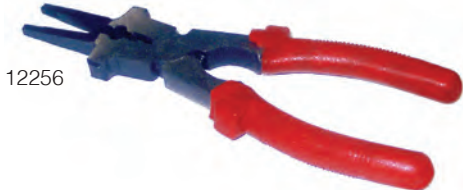

12256

MIG WELDER PLIERS FOR MULTIPLE JOBS

This special designed Mig Plier is a must for all welders. It acts as a multi-purpose tool with multiple functions.

Item#	Description	Pkg. Qty.
12256	Mig Plier	1



12258

WELDERS UTILITY KNIFE

This general purpose knife comes in handy for many jobs. A welder's essential tool.

Item#	Description	Pkg. Qty.
12258	Knife with 4 replacement blades	1



10999

WELDING MANUAL

Contains basic guidelines for arc welding.

Item#	Description	Qty.
10999	Welding Manual	1

WALL RECEPTACLE AND PLUGS

Choose from the pin style used for 2 pole, 3 wire grounding and surface mounted; or the crowfoot style with 3 equal slots and used for 2 pole, 3 wire grounding.

Male pin type plug has two brass blades and half pin, where the male crowfoot plug has three heavy duty brass blades.

Both are made of hardened bakelite and use 125/250 volt, 50 amps (pin type requires 250 volt). Made in México.

Item#	Description	Pkg. Qty.
12224	Pin Type Wall Receptacle (Parallel Blade)	1
12225	Crowfoot Type Wall Receptacle	1
12235	Male Pin Type Plug (Parallel Blade)	1
12236	Male Crowfoot Plug	1

RECEPTACLES

20 Amp, U.L. Listed Receptacles. Made in México

Item#	Description	Pkg. Qty.
12246	20 Amp Max, 250 Volt	1
12249	20 Amp Max, 125 Volt	1





CRIMPING TOOL/CABLE LUGS/TANK ADAPTERS



CRIMPING TOOL

For crimping of copper terminal lugs. This heavy duty crimping tool is designed for ease. The spring action plunger quickly crimps lugs with the use of a hammer.

Item#	Dimensions	Net Weight	Pkg. Qty.
12247	2" x 3 1/4"	1.6 lb.	1



CABLE LUGS

Made from copper and designed for a solid connection. Easy to swage and/or crimp.

Item#	Cable Size	Supports	Pkg. Qty.
12300	8	#10	2
12301	6	1/4"	2
12302	4	5/16"	2
12303	4	3/8"	2
12304	2-3	5/16"	2
12305	1	3/8"	2
12306	1/0	3/8"	2
12308	2/0	3/8"	2
12309	2-6	3/8"	2
12310	2/0	1/2"	2
12311	3/0	1/2"	2
12312	4/0	1/2"	2
12313	1-2	1/2"	2
12314	2-6	1/2"	2
12315	1/0-2/0	1/2"	2



TANK ADAPTERS

Made for connections of oxygen and acetylene cylinders. For use in connecting a regulator to a tank with dissimilar connections.

Item#	Description	Pkg. Qty.
12412	Adapts CGA580 to CGA320	1
12413	Adapts CGA520 to CGA510 - B Tanks	1
12414	Adapts CGA520 to CGA200	1
12415	Adapts CGA510 to CGA520 - B Tanks	1
12416	Adapts CGA510 to CGA510 Rt. Angle	1
12418	Adapts CGA510 to CGA300	1
12419	Adapts CGA320 to CGA580	1
12421	Adapts CGA200 to CGA510 - MC Tanks	1

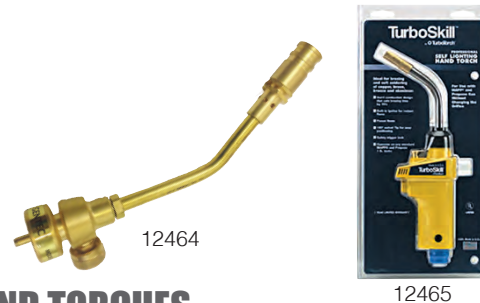

HAND TORCHES

Two levels of torches - for the do-it-yourselfer and the everyday professional.

Item#	Description	Pkg. Qty.
12464	Do-it-yourself pencil flame solid brass construction flame control valve. For use on 1 lb. propane tanks. Use for soldering - thawing pipes light maintenance. One year warranty.	1
12465	180 degree swivel tip, safety trigger lock. Use with standard mapp and 1 lb propane tank. Swirl combustion design, UL listed CGA600 Connection. One year warranty - Made in USA	1

TORCH CARBONS/CYLINDER WRENCHES/HOSE/CRIMPING TOOL

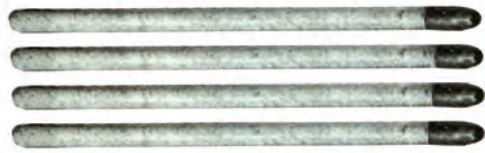

12462

ARC TORCH CARBONS

Copper coated, these carbons are break resistant.

Item#	Size	Pkg. Qty.
12462	1/4"	10
12463	3/16"	10



16100

10-WAY CYLINDER WRENCH

Made from forged steel, this wrench has 10 openings. Sizes include: 7/16", 1/2", 9/16", 5/8", 11/16", 7/8", 1", 1 1/8" plus a 1/4" socket and a 3/8" square BMC.

Item#	Dimensions	Wt.	C.O.O.	Pkg. Qty.
16100	8 1/2" x 2 1/2"	.85 lbs	Made in China	1



16101

CYLINDER WRENCH

3/8" square opening for use on acetylene tanks.

Item#	Size	C.O.O.	Pkg. Qty.
16101	5" Long	Made in Taiwan	1



16102

16103

T-TYPE CYLINDER WRENCH

For use on acetylene tanks. Durable steel construction. 5" T-bar and 6" shank.

Item#	Size	C.O.O.	Pkg. Qty.
16102	3/8"	Made in Taiwan	1
16103	1/4"	Made in China	1



12263

OXY-ACETYLENE HOSE SET

This rugged Type "R", flexible hose is kink proof and has a neoprene cover. Rated to 100 PSI.

Item#	Diameter	Length	Pkg. Qty.
12263	3/16"	12.5'	1
12264	3/16"	20'	1
12265	3/16"	25'	1
12266	3/16"	50'	1
12268	1/4"	12.5'	1
12270	1/4"	25'	1
12271	1/4"	50'	1



12261

HOSE REPAIR CRIMPING TOOL

Used to perform hose fitting repairs

Item#	Dimensions	Wt.	Pkg. Qty.
12261	8 3/4" x 2 1/2" x 1/2"	1.3	1



REPAIR KIT/CLAMPS/FERRULES/BRACES/COUPLERS/NUTS



12260

OXY-ACETYLENE HOSE REPAIR KIT

Kit is complete with splicers, hose nuts, nipples, ferrules and couplers. Also includes a vise grip type crimping tool.

Item#	Dimensions	Wt.	Pkg. Qty.
12260	10 3/4" x 6 1/2" x 1 1/2"	3.7 lbs.	1



12283

OXY-ACETYLENE HOSE END REPAIR KIT

Set includes two complete hose end sets for 3/16" or 1/4" hose.

Item#	Size	Sets
12283	3/16"	2
12284	1/4"	2



12274



12275

HOSE BRACE

Item#	Size	Type	Pkg. Qty.
12274	3/16"	Oxy - Acetylene	5
12275	1/4"	Oxy - Acetylene	5



12287



12290

HOSE CLAMPS

Hose clamps available in 2 sizes.

Item#	Size	Pkg. Qty.
12290	3/16"	2
12289	1/4"	2



12272

BRASS HOSE FERRULES

Item#	Size	Type	Pkg. Qty.
12272	3/16"	Oxy - Acetylene	5
12273	1/4"	Oxy - Acetylene	5



12278

HOSE COUPLERS "B" FITTING

Item#	Type	Pkg. Qty.
12278	Acetylene	2
12279	Oxygen	2

HOSE NUTS

Item#	Size	Type	Pkg. Qty.
12287	9/16"	Acetylene	2
12288	9/16"	Oxygen	2

SPLICERS/CONNECTORS/NIPPLES/GAUGES



12281



12285

OXY-ACETYLENE HOSE SPLICERS

Used for joining 3/16" or 1/4" ends.

Item#	Size	Type	Pkg. Qty.
12280	3/16"	Oxy - Acetylene	2
12281	1/4"	Oxy - Acetylene	2



12294

OXY - ACETYLENE CONNECTORS

Used for joining 3/16" or 1/4" ends.

Item#	Hose Size	Type/Connection Sz.	Set
12291	1/4" ID	Oxygen to 1/4"	1
12292	1/4" ID	Acetylene to 1/4"	1
12293	3/16" ID	Oxygen to 3/16"	1
12294	3/16" ID	Acetylene to 3/16"	1

OXY-ACETYLENE GAUGES

High quality, bourdon-tube style gauges.

1 1/2" Acetylene For Light Duty Kit #150

Item#	Type	Size	Pounds	Pkg. Qty.
12440	Acetylene Only	1/8"NPT	0-400	1
12441	Acetylene Only	1/8"NPT	0-4000	1

2" For Medium Duty Kit #250

Item#	Type	Size	Pounds	Pkg. Qty.
12422	Acetylene Only	1/4"NPT	0-30	1
12423	All Gases	1/4"NPT	0-60	1
12424	All Gases	1/4"NPT	0-100	1
12425	All Gases	1/4"NPT	0-400	1
12426	All Gases	1/4"NPT	0-4000	1

2 1/2" for Heavy Duty Kit #350

Item#	Type	Size	Pounds	Pkg. Qty.
12427	Acetylene Only	1/4"NPT	0-30	1
12428	All Gases	1/4"NPT	0-200	1
12429	All Gases	1/4"NPT	0-400	1
12430	All Gases	1/4"NPT	0-4000	1

OXY-ACETYLENE HOSE SPLICER KIT

Set includes one splice coupler for connecting a 3/16" torch to a 1/4" hose.

Item#	Size	Set/Pcs.
12285	3/16"	1
12286	1/4"	1



12276

BARBED HOSE NIPPLES

Item#	Size	Type	Pkg. Qty.
12276	3/16"	Oxy-Acetylene	2
12277	1/4"	Oxy-Acetylene	2



12440



12422



12428



ARRESTORS/VALVES/REGULATORS



12447



12449

FLASHBACK ARRESTORS

Item#	Type	Description	Pkg. Qty.
12446	Torch	with check valves	2
12447	Regulator	with check valves	2
12448	Kwik-Connect	"B" 9/16"-18 Threads	2

REVERSE FLOW CHECK VALVES

Valves used to prevent gases from backing up and mixing in the regulators. For use on single or two stage regulators with 1/4" NPT outlet.

Item#	Description	Pkg. Qty.
12449	1/4" NPT - 2 pcs	2



12454

SINGLE STAGE REGULATORS

Replacements For Series 150 Kits-UL Listed

Item#	Type	Size	Pounds
12454	Oxygen	50 mm	540 CGA, 4-60 PSIG
12455	Acetylene	50 mm	510 CGA, 2-15 PSIG

Replacements For Series 250 Kits-UL Listed

Item#	Type	Size	Pounds
12459	Oxygen	2"	540 CGA, 5-125 PSIG
12460	Acetylene	2"	510 CGA, 2-15 PSIG

Replacements For Series 350 Kits-UL Listed

Item#	Type	Size	Pounds
12442	Oxygen	2 1/2"	540 CGA, 2-125 PSIG
12443	Oxygen	2 1/2"	540 CGA, 10-200 PSIG
12444	Acetylene	2 1/2"	510 CGA, 2-15 PSIG
12445	Acetylene	2 1/2"	300 CGA, 2-15 PSIG



12444



PN 12250
NOZZLE OIL
For MIG GUN Nozzles & Contact Tips
16 Fl. Oz. (473 mL)
Regulador De Boquilla
16 onzas líquidas (473 mL)
Bain De
16 oz liq. (473 mL)
Pour les becs de contact et les buses des PISTOLES
16 oz liq. (473 mL)
NOT Subject to WHMIS
conforme a WHMIS
pas soumis au SIMDUT



SHARK INDUSTRIES

Safety Equipment

- ▶ Welding Shields
- ▶ Headgear
- ▶ Goggles
- ▶ Glasses
- ▶ Ear Protection
- ▶ Masks
- ▶ Hard Hats
- ▶ Gloves
- ▶ Welding Apparel
- ▶ Welding Screens
- ▶ Welding Blankets





WELDING SHIELDS



14315

DELUXE WELDERS HAND HELD FACE SHIELD

This easy hand held shield is ergonomically designed with a hand hole large enough to fit a gloved hand. It is light weight and can fit in either hand.

The viewing area is 2" x 4 1/4" with a shade 10 lens and cover plate. Ideal for small jobs or as protection when other people are welding. Meets ANSI Z87.1-1989 and CSA-Z94.3-92 SEI Certified

Item#	Description	Pkg. Qty.
14315	Hand Held Welding Shield	1



14316

ECONOMY WELDERS HAND HELD FACE SHIELD

Easy, economical hand held shield is an inexpensive way to protect yourself on small welding jobs.

The viewing area is 2" x 4 1/4" with a shade 9 lens and cover plate. Ideal for small jobs or as protection when other people are welding. Meets ANSI Z87.1-1989 and CSA-Z94.3-92 SEI Certified

Item#	Description	Pkg. Qty.
14316	Economy Hand Held Welding Shield	1



14319

GRINDING SHIELD

These grinding shields are designed for use while using various power tools. Protects from harmful exposure to dangerous wheels and flying debris.

Item#	Description	Pkg. Qty.
14317	Clear Pinlock Headgear 8" x 12"	1
14318	Green Pinlock Headgear 8" x 12"	1
14319	Clear Ratchet Headgear 8" x 15 1/2"	1
14320	Green Ratchet Headgear 8" x 15 1/2"	1

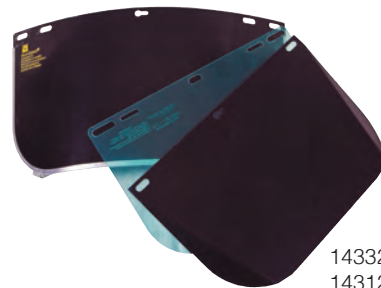

14332
14312
14313

REPLACEMENT GRINDING SHIELD

Replacement face shield comes in 8" x 12" or 8" x 15 1/2" and made from plastic.

Item#	Description	Pkg. Qty.
14312	Clear 8" x 12"	1
14313	Green 8" x 12"	1
14310	Clear 8" x 15 1/2"	1
14311	Green 8" x 15 1/2"	1
14331	Clear 8" x 15 1/2" w/ Metal Rim	1
14332	Green 8" x 15 1/2" w/ Metal Rim	1

HEADGEAR



14333



14314



14117

REPLACEMENT HEADBAND AND HEADGEAR

Headband will work on item #14317 - #14320 welding shields.

Item#	Description	Pkg. Qty.
14314	Comfortable Headband Cover	1
14333	Visor Headband Ratchet Headgear (no shield)	1
14334	Visor Headband Pinlock Headgear (no shield)	1



14118

RATCHET HEADGEAR

This headgear has a ratchet type adjustment for headband and pin type for crown strap. Use with item #14101-14105, 14109, 14112.

Also works with all Sellstrom helmets.

Item#	Description	Pkg. Qty.
14118	Ratcheting Headgear	1

PIN HEADGEAR

This headgear has a pin type adjustment for headband and crown strap. Use with item number #14101-14105, #14109, 14112, 14317-20.

Also works with all Sellstrom helmets.

Item#	Description	Pkg. Qty.
14117	Pin Headgear - Crown and Headband	1



14119

RATCHET HEADGEAR

This headgear is made from pliable, long lasting plastic that won't stiffen. Straps are easy adjusting for head size and crown fit. There are pivot points for the helmet that are extended from the headband to eliminate pressure on sides of the head.

Item#	Description	Pkg. Qty.
14119	Headgear-Ratcheting for Jackson/Morsafe	1
14120	Headgear-Universal Ratcheting for Off-Shore Helmets	1
14142	Replacement Headgear for Shark Graphic Helmets	1
14278	Replacement Headgear for Shark 14272	1



SAFETY GOGGLES



14300

CLEAR PLASTIC GOGGLES

Goggles fit over regular eyeglasses and are perforated for good ventilation.

Good for use as general purpose safety protector in industry, workshop, farming and sports.

Item#	Pkg. Qty.
14300	1



14303

FOG-FREE VENTED GOGGLES

Made for easy viewing, ventilation and comfort. The acetate lens conforms to the eye area for a light-tight seal. Can be used over glasses.

Item#	Pkg. Qty.
14303	1



14301

LIGHT GREEN PLASTIC GOGGLES

Lens is light green shaded with clear sides. Not for oxy-acetylene welding.

Item#	Pkg. Qty.
14301	1



14329

CAMOUFLAGE GOGGLES

Camouflage goggles! Lens is dark green #5 shade for protection. Comfort head strap has velcro closure.

Item#	Pkg. Qty.
14329	1



14302

EYE CUP GOGGLES

These 50 mm goggles are heat treated, #5 shade lenses. Easily folds up to carry in your pocket.

Item#	Pkg. Qty.
14302	1



14305

CUP STYLE ACETYLENE GOGGLES

Made from soft vinyl with #5 heat treated lenses on this aviator shaped goggle. Air vents to prevent fogging. Designed to be worn over regular eyeglasses.

Item#	Pkg. Qty.
14305	1

SAFETY GOGGLES/GLASSES



14306

50MM STATIONARY ACETYLENE GOGGLES

Made from soft vinyl that forms to the head. Six vents prevent fogging. Goggles have a 50 mm, #5 lens and a pit resistant cover lens.

Item#	Pkg. Qty.
14306	1



14307

50MM FLIP-UP OXY-ACETYLENE GOGGLES

Made from soft vinyl that forms to the head. Six vents prevent fogging. Goggles have a 50 mm, #5 flip-up lens and a pit resistant cover lens.

Item#	Pkg. Qty.
14307	1



14308

BOX STYLE STATIONARY ACETYLENE GOGGLES

Made from soft vinyl that forms to the head. Six vents prevent fogging. Goggles have a 2" x 4 1/4", #5 lens and a pit resistant cover lens.

Rectangle shape designed to be worn over regular eyeglasses or with a magnifying lens.

Item#	Pkg. Qty.
14308	1



14309

BOX STYLE FLIP-UP ACETYLENE GOGGLES

Made from soft vinyl with a 2" x 4 1/4", #5 flip-up lens and air vents to prevent fogging.

Item#	Pkg. Qty.
14309	1



14330

ELASTIC HEADBAND FOR GOGGLES

Adjustable, replacement headband for many type of goggles.

Item#	Pkg. Qty.
14330	4



14338

PROTECTIVE GLASSES

These clear, stylish wrap-around design frame glasses have a curved lens for a snug, secure fit. Durable/scratch-resistant. ANSI Z87.1

Item#	Pkg. Qty.
14338	1



SAFETY GLASSES



14339



14342

COMFORT DESIGNED SAFETY GLASSES

Innovative frame design fits all face shapes. Impact and scratch resistant lens. UV400 coating & ANSI Z87.

Item#	Shade	Pkg. Qty.
14339	Clear	1

FASHIONABLE GLOSS FINISH SAFETY GLASSES

Curve style safety glasses with two piece anti-scratch PC lens. Rubber leg foot and nose bridge. UV400 coating & ANSI Z87.1

Item#	Shade	Pkg. Qty.
14342	Clear	1



14344

14343



14321

14322

FRAMELESS SAFETY GLASSES

Economical fashionable light weight frameless style safety glasses with slim temple leg and soft rubber temple cover. ANSI Z87.1 + CE EN 166.

Item#	Shade	Pkg. Qty.
14343	Smoked	1
14344	Clear	1

PROTECTIVE TRI-SHIELD GLASSES

Glasses have a top and flat folding side shield with a polycarbonate safety lens.

Item#	Shade	Pkg. Qty.
14321	Clear	1
14322	#5 Green	1



14323



14327

21ST CENTURY PROTECTIVE GLASSES

Glasses have a flat folding side shield with a safety lens.

Item#	Shade	Pkg. Qty.
14323	#3 Green	1
14324	#5 Green	1

PROTECTIVE TRI-SHIELD GLASSES

Clear visitor safety glasses are inexpensive, one-size-fits-all glasses that will easily fit over regular eyeglasses. Not for any welding use.

Item#	Type	Shade	Pkg. Qty.
14327	Visitor	Clear	1
14328	Visitor	Smoke	1

EAR/AIR PROTECTION



14425



14422

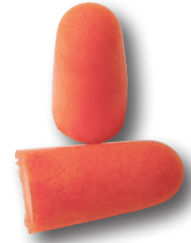

14463

NOISE PROTECTION EAR MUFFS

Comfortable and lightweight ear muffs with a self-aligning adjustable strap. For maximum protection and safety from the worst levels of noise. Also has self-aligning ear cups. Can be used for most common levels of industrial noise.

Item#	Pkg. Qty.
14425	1

REUSABLE EAR PLUGS

Comfortable ear plugs with or without neck string.

Item#	Description	Pkg. Qty.
14422	Ear plugs with neck string in box	1 pair
14423	Ear plugs in plastic box-Medium	1 pair
14424	Ear plugs in plastic box-Large	1 pair
14463	Disposable Ear Plugs	12 pair



14418



14421



14417

HALF MASK RESPIRATORS

Half Mask respirator comes with either a metal fume cartridge for welding or a cartridge set-up for paint fume protection.

Item#	Description	Pkg. Qty.
14416	Paint Fume Respirator	1
14417	Welding Fume Respirator	1
14418	Paint Fume Replacement Cartridge	2
14419	Welding Fume Replacement Cartridge	2
14421	Welding Fume Replacement White Filters	10



MASKS/EYE WASH STATION/HARD HATS



14426



14428

CUSTOM FIT DUST MASKS

Masks are made from an extremely absorbent filter material and are lightweight. Metal tab to secure tightly to your nose. Use for lab work, grinding, sanding and dusty work areas. Not for use when toxic fumes or other harmful dust is present.

Item#	Old#	Pkg. Qty.
14426	80-10	10
14427	80	50/bx.

ACID RESISTANT DUST MASKS

NIOSH approved N95 Valved Particulate Mask with 95% filtration. Effective against particulate aerosols free of oils.

Item#	Description	Pkg. Qty.
14428	Valved respirator	10



14432

GRAVITY FEED PORTABLE EYE WASH STATION

This SEI Certified 16 gallon eye wash unit comes with a zinc plated steel wall mounting bracket, drain hose and one bottle of Redi-Sep bacteriostatic additive with test log card. Flow activates in less than 1 second. Unit weighs only 16 lbs and has a flow duration of over 15 minutes at a rate of .4 gallons per minute

Item#	Description	Pkg. Qty.
14432	16 gallon unit with bottle of Redi-Sep	1
14433	8 oz. bottle of Redi-Sep	1
14435	Dust Cover for 16 gallon Station	1



14439



14448



14440



14441

HARD HATS

For maximum protection from electrical hazards or general impact and penetration protection. Meets ANSI Z89.2 regulations and CS-22. ABS or HDPE material. Woven Band or Ratcheting Suspension. Hats and headgear sold separately.

Item#	Description	Pkg. Qty.
14438	Red HDPE Shell No Headgear	1
14439	Yellow ABS Shell No Headgear	1
14448	White ABS Shell No Headgear	1
14440	Woven Suspension & Headgear-Medium	1
14441	PE suspension Headgear-Medium	1
14442	Chin Strap (not shown)	1

LEATHER WELDING GLOVES



14402

BROWN LEATHER WELDING GLOVE

Brown leather welding gloves. Protect against sparks, hot metal and slag.

Item#	Size	Pkg. Qty.
14402	Large	1



14401

GREY ECONOMY LINED LEATHER WELDING GLOVES

These 15 1/2" long gloves are heavy duty, heat resistant and have a gauntlet for protection. They offer average protection while welding. Protects against sparks and hot metal.

Item#	Size	Pkg. Qty.
14401	Large	1



14403

BLUE DELUXE WELDING GLOVES

These 15 1/2" long gloves are superior quality. They have a fully lined interior to insulate against heat and have a gauntlet for protection. One piece back is made of shoulder split leather.

Item#	Size	Pkg. Qty.
14403	Large	1



14525

BLUE EXTRA HEAVY DUTY GLOVES

This top-of-the-line, Kevlar lined glove is 15 1/2" long. The gun cut with wing thumb construction offers you extra life. These 2-toned welding gloves are extra thick for added protection when you need it while welding or moving hot items.

Item#	Size	Pkg. Qty.
14525	Large	1



LEATHER WELDING/WORK GLOVES



14404

LEATHER WELDING GLOVES

These deluxe red thermal lined gloves protect against sparks, hot metal and slag. Gun cut with wing thumb, lock stitch construction has a one-piece back and are 16" long. Made with shoulder split leather, these are our better gloves.

Item#	Size	Pkg. Qty.
14404	Large	1



14400

TIG GLOVES

These premium leather gloves are made of top grain leather. They will withstand moisture, unlined for maximum dexterity and are 14" long.

Item#	Size	Pkg. Qty.
14400	Large	1



14414

LEATHER WORK/DRIVER GLOVES

These gloves are made of select, side split cowhide. Gloves are lightweight, soft and pliable. 9" Length.

Item#	Size	Pkg. Qty.
14414	Large	1



14399

TWO-TONE GOAT/SHEEP SKIN DRIVER GLOVES

Driver glove made of goat/sheep skin and a heavy duty spandex material on the top for comfort.

Item#	Size	Pkg. Qty.
14399	Large	1



14415

LEATHER PALMED ECONOMY WORK GLOVES

Shoulder split cowhide on palms, thumb and index finger. Gun cut with cotton band and back.

Item#	Size	Pkg. Qty.
14415	Large	1

WELDING APPAREL



PROTECTIVE LEATHER WELDING SLEEVES

These 18" slide on leather sleeves have an elastic cuff and an adjustable tab at the bicep. Great for forearm protection while welding as well as working in the yard cutting prickly bushes, and other situations where arm protection is required.

- Welding/Work Sleeves
- 100% Cowhide Leather
- 18" Length
- Elastic Cuff with Adjustable Biceps
- Heat Resistant

Item#	Description	Pkg.Qty.
14519	Leather welding/work sleeves	1 Pair



14520

LEATHER WELDING JACKET

Leather is the best form of protection when it comes to Welding. Exceptionally good when welding overhead, our top quality grain leather jackets will offer an extended life protection over saateen. Available in sizes from Large to 3-XL, these jackets are comfortable and easy to wear.

Item#	Size	Pkg. Qty.
14520	Large	1
14521	X-Large	1
14522	XX-Large	1
14523	XXX-Large	1



14524

LEATHER WELDING APRON

Our quality top grain leather welding apron will afford you protection when and where you need it. Available in large, the ties are long enough to fit most sizes.

Item#	Size	Pkg.Qty.
14524	Large	1



WELDING APPAREL

WELDING JACKET



14503

Jacket is 30" long and is made from green 9 oz. fire resistant 100% sateen cotton with a snap front, full length sleeves that have a snap cuff and a stand up collar.

Item#	Size	Pkg.Qty.
14503	Large	1
14504	X-Large	1
14505	XX-Large	1
14510	XXX-Large	1



WELDER'S CAPE SLEEVE WITHOUT BIB

Cape sleeves are made from green 9 oz. fire resistant 100% sateen cotton with a snap front. Full length sleeves have a snap cuff and a stand up collar.

Item#	Size	Pkg.Qty.
14506	Large	1
14507	X-Large	1
14508	XX-Large	1

WELDING APRON



14500

Apron Material is green 9 oz. fire resistant 100% sateen cotton and has standard sewn ties.

Item#	Size	Pkg.Qty.
14500	Large	1
14501	X-Large	1
14502	XX-Large	1
14511	XXX-Large	1

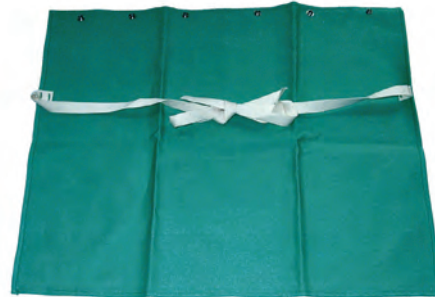

WELDER'S BIB

This 20" long, 100% sateen cotton bib is made to snap on to the cape sleeves for lower body protection while welding.

Item#	Size	Pkg.Qty.
14509	Large	1

WELDING APPAREL

ASSORTED WELDING HATS



14452



14455



14458



14468

Made of breathable cotton, these hats will offer protection with their wide, soft brims. Available in popular prints and colors.

Item#	Description	Size	Pkg. Qty.
14452	Red – Polka Dot	7 1/4"	1
14453	Red – Polka Dot	7 3/8"	1
14454	Red – Polka Dot	7 1/2"	1
14455	Green – Polka Dot	7 1/4"	1
14456	Green – Polka Dot	7 3/8"	1
14457	Green – Polka Dot	7 1/2"	1

Item#	Description	Size	Pkg. Qty.
14458	Assorted Wild Prints	7 1/4"	1
14459	Assorted Wild Prints	7 3/8"	1
14460	Assorted Wild Prints	7 1/2"	1
14466	Camo Print	7 1/4"	1
14467	Camo Print	7 3/8"	1
14468	Camo Print	7 1/2"	1



14450



14450

BLACK QUILTED SKULL CAP

This flat crowned, firm brimmed hat is quilted and perfect for welding.

Item#	Size	Pkg. Qty.
14461	7 1/4"	1

BLACK COTTON WELDING BEANIES

Black cotton welding beanie for light weight protection under your helmet when a brim is not required.

Item#	Size	Pkg. Qty.
14450	Large	1
14451	Extra Large	1



14469

Underside view

NEW!

ORANGE WELDING HAT

This hat provides lightweight protection, while also remaining breathable. One size fits all!

- Washable
- Cotton flame-retardant fabric
- Breathable mesh lining
- Wide brim

Item#	Description	Pkg. Qty.
14469	Cotton mesh-lined hat	1



WELDING SCREENS

WELDER'S STUR-D-SCREEN

Square steel tubing adds stability and support to this special orange heavy duty vinyl welding screen. Provides 100% of far U.V. Radiation and 100% of Blue Light protection. Portable, light weight design makes this an easy product to use and transport.

Item#	Size	Weight
14443*	6' High x 4' Wide	23 lbs.
14866*	6' High x 6' Wide	27 lbs.
14868*	6' High x 8' Wide	31 lbs.

*The item number represents only a single panel.



12255



12394

WELDING BLANKETS

These fiberglass and silicone welding blankets afford spark and molten metal protection.

Offered in a variety of sizes and materials, they allow for different working temperature ranges of up to 1500 degrees Fahrenheit.

Item#	Old#	Description	Working Temperature	Size	Pkg. Qty.
12395	906-46	Vermiculite Coated Fiberglass Blanket - Single Layer, 25 oz.	1500° F	4' x 6'	1
12396	906-66	Vermiculite Coated Fiberglass Blanket - Single Layer, 25 oz.	1500° F	6' x 6'	1
12398	640-46	Vermiculite Coated Fiberglass Blanket - Double Layer, 50 oz.	1500° F	4' x 6'	1
12399	640-66	Vermiculite Coated Fiberglass Blanket - Double Layer, 50 oz.	1500° F	6' x 6'	1
12255		Silicone Coated Fiberglass Welding Blanket - Single Layer with Pocket	500° F	38" x 24"	1
12394		Black Carbon Fiber Welding Blanket	3000° F	54" x 60"	1

NEW! PAINT PENS

- Most durable nib in the industry
- Marks won't chip, peel, fade or rub off
- Precision valve accurately meters flow
- Twelve pens per box (one color per box)
- Marks on metal, plastic, glass, wood, etc.
- Withstands temperatures in excess of 400°F/205°C
- Easily writes on any surface: porous or non-porous, rough or smooth, wet, oily or dry
- Made in the USA

Item#	Color
16501	White
16502	Black
16503	Blue
16504	Red
16505	Yellow
16506	Green
16507	Silver
16508	Orange



(Display box free with purchase of 48 pens.)



SHARK INDUSTRIES

Cutting Kits

- ▶ Medium Duty
- ▶ Heavy Duty
- ▶ Plumber's Kit





VICTOR STYLE WELDING & CUTTING KITS W/BUILT-IN FLASH BACK ARRESTORS

250 BASIC VICTOR STYLE MEDIUM DUTY WELDING & CUTTING KIT



12402

This medium duty kit was designed for the craftsman or mechanic. Welds up to 5/64" thick or up to 1 1/4" with optional nozzles. Cuts up to 1/2" thick with supplied tip or up to 5" with optional cutting tips. Includes a larger welding handle than the light duty kit, #0 welding tip, larger cutting attachment and 0-3-101 cutting tip, medium duty oxygen and acetylene regulators, 1/4" x 15' twin hose, goggles and striker. Built-in flash back arrestors for added safety!

Dimension: 19 1/2" x 14" x 4 1/2" • Weight: 15 lbs.

Item#	Description	Pkg. Qty.
12402	Total Kit with Hose	1
12577	#0 Cutting Tip cuts up to 1/2"	1
12599	#0 Welding Tip	1
12490	Medium Duty Cutting Attachment	1
12491	Medium Duty Torch Handle	1
12459	Single Stage 250 Oxygen Regulators	1
12460	Single Stage 250 Acetylene Regulators	1
12237	Striker	1
12242	Tip Cleaner	1
14305	Goggles	1
	1/4" x 15' Twin Hose**	1

**Reorder 12270 hose which is 1/4" x 25'. 15' not available as regular number.

250 DELUXE VICTOR STYLE MEDIUM DUTY WELDING & CUTTING KIT INCLUDES ADDITIONAL ROSEBUD TIP AND 2 WELDING TIPS



12403

This Victor comparable kit was designed for automotive or construction use. Welds up to 1/4" thick up to 1 1/4" with optional nozzles. Cuts up to 1/2" thick - or 6" with optional cutting tips. Includes a medium duty torch handle. #0, #2, and #4 welding nozzle, medium duty cutting attachment and medium duty oxygen and acetylene regulators, 1/4" x 15' twin hose, goggles and striker complete the kit. Compared to the basic kit #12402, this includes an additional rosebud tip and 2 welding tips. Built-in flash back arrestors for added safety!

Dimension: 19 1/2" x 14" x 4 1/2" • Weight: 17 lbs.

Item#	Description	Pkg. Qty.
12403	Total Kit with Hose	1
12577	#0 Cutting Tip cuts up to 1/2"	1
12599	#0 Welding Tip	1
12601	#2 Welding Tip	1
12603	#4 Welding Tip	1
12604	#6 Heating Rosebud	1
12490	Medium Duty Cutting Attachment	1
12491	Medium Duty Torch Handle	1
12459	Single Stage 250 Oxygen Regulators	1
12460	Single Stage 250 Acetylene Regulators	1
12237	Striker	1
12242	Tip Cleaner	1
14305	Goggles	1
	1/4" x 15' Twin Hose**	1

**Reorder 12270 hose which is 1/4" x 25'. 15' not available as regular number.

350 VICTOR STYLE HEAVY DUTY KIT

This heavy duty Victor-Journeyman compatible kit was designed for industrial or commercial use. Welds up to 1/2" (3" capability with optional nozzles). Cuts up to 3/4" thick with supplied #1 tip or up to 8" with optional cutting tips. Includes a larger welding handle than the medium duty kit, #1, #3 and #5 welding nozzles included. Heavy duty regulators, 1/4" x 15' twin hose, goggles and striker complete the kit. Built-in flash back arrestors for added safety!

Dimension: 19 1/2" x 14" x 4 1/2" • Weight: 24 lbs.

Item#	Description	Pkg. Qty.
12401	Total Kit with Hose	1
12555	#1 Cutting Tip cuts up to 3/4"	1
12570	#1 Welding Tip	1
12572	#3 Welding Tip	1
12670	#5 Welding Tip	1
12574	#8 Heating Rosebud	1
12671	Heavy Duty Torch Handle	1
12672	Heavy Duty Journeyman Style Cutting Attachment	1
12443	Heavy Duty Oxygen Regulators	1
12444	Heavy Duty Acetylene Regulators	1
12237	Striker	1
14305	Goggles	1
	1/4" x 15' Twin Hose**	1

**Reorder 12270 hose which is 1/4" x 25'. 15' not available as regular number.



12401

OXYGEN-ACETYLENE TOTE KIT

This super range compatible kit welds up to 3/16" (expandable to 1 1/4") and cuts up to 1/2" (6" with optional tips). Designed for portability, this medium to light weight outfit allows you to take the torch to the job. Includes everything except the gas. Made in Taiwan.

Weight: 37 lbs.

Item#	Description	Pkg. Qty.
12411	Tote with Cylinders	1
12491	260C Series Torch Handle	1
12490	250 Series Cutting Attachment	1
12599	#0 Welding Nozzle up to 3/16"	1
12577	#0 Cutting Tip Cuts to 1/2"	1
12470	Light Duty Oxygen Regulators (CGA540)	1
12471	Light Duty Acetylene Regulators (CGA200)	1
12263	3/16" x 12.5' Dualine Hose	1
12237	Striker	1
14302	Shade #5 Goggles	1

(Cylinders Shipped Empty)



12411

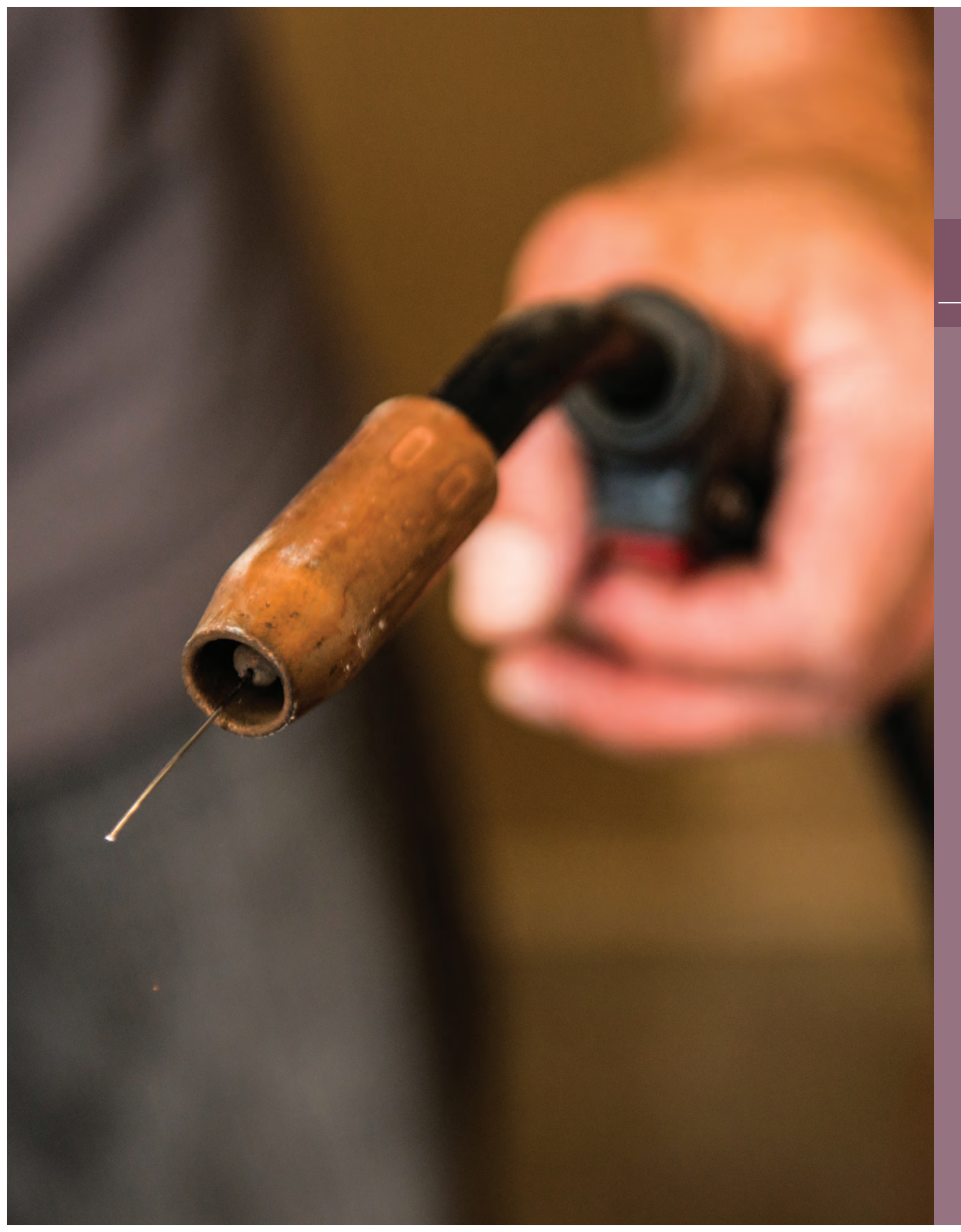

SHARK INDUSTRIES

Tips & Nozzles

- ▶ Welding, Cutting & Gouging Tips
 - Airco
 - Firepower
 - Harris
 - Marquette
 - Purox
 - Smith
 - Victor
- ▶ Mig Contact Tips
- ▶ Mig Gun Nozzles
- ▶ Torch Liners





AIRCO/HARRIS WELDING & CUTTING TIPS



12502



12509



12504



12513

AIRCO STYLE CUTTING TIPS

Available in 2 types of tips. Both tips have a medium preheat and are used for general cutting. The Acetylene tip is a 144 series and the Propane/Natural Gas is a 261 series.

Item#	Tip Size	Type	Series	Pkg. Qty.
12500	0	Acetylene	144	1
12501	1	Acetylene	144	1
12502	2	Acetylene	144	1
12503	3	Acetylene	144	1
12504	1	Propane/Natural Gas	261	1

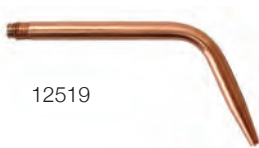

12519

HARRIS STYLE ACETYLENE WELDING TIP

This elbow style is a 23-A-90 series and is used with the E-43 mixer.

Item#	Tip Size	Type	Pkg. Qty.
12518	0	Acetylene	1
12519	1	Acetylene	1
12520	2	Acetylene	1
12521	3	Acetylene	1



12525

HARRIS STYLE OXY-ACETYLENE MIXER

This mixer is an E-43 series and is used with the 23-A-90 elbow.

Item#	Type	Series	Pkg. Qty.
12525	Oxy-Acetylene	E-43	1

HARRIS STYLE CUTTING TIPS

Available in 2 types of tips. Both tips have a medium preheat and are used for general cutting. The Acetylene tip is a 6290 series and the Propane/Natural Gas is a 6290-NX series. Fits a Harris model 85 torch handle.

Item#	Tip Size	Type	Series	Pkg. Qty.
12505	000	Acetylene	6290	1
12506	00	Acetylene	6290	1
12507	0	Acetylene	6290	1
12508	1	Acetylene	6290	1
12509	2	Acetylene	6290	1
12510	3	Acetylene	6290	1
12511	4	Acetylene	6290	1
12512	00	Propane/Natural Gas	6290-NX	1
12513	0	Propane/Natural Gas	6290-NX	1
12514	1	Propane/Natural Gas	6290-NX	1
12515	2	Propane/Natural Gas	6290-NX	1
12516	3	Propane/Natural Gas	6290-NX	1
12517	4	Propane/Natural Gas	6290-NX	1

ACETYLENE/OXYGEN EASY SIZE CHART

Metal Thickness	Tip Size	Pressures: ACT	Oxygen
1/8"	0	3-5	20-25
1/4"	00	3-5	20-25
3/8"	0	3-5	25-35
1/2"	0	3-5	30-35
3/4"	1	3-5	30-35
1"	2	3-5	35-40
2"	3	4-8	40-45

MARQUETTE/PUROX/SMITH CUTTING TIPS



12528



12530

MARQUETTE STYLE STAR JET CUTTING TIP

This one piece, medium duty tip is made from solid copper and has a slip-in design. The seat is tapered for a positive gas seal and has four preheat holes to ensure efficient cutting results. Tip has a medium preheat.

General purpose tip.

Item#	Tip Size	Type	Series	Pkg. Qty.
12527	1	Acetylene	GW4	1
12528	3	Acetylene	GW4	1
12529	4	Acetylene	GW4	1



12532

MARQUETTE STYLE STAR JET CUTTING TIP

This one piece, heavy duty tip is made from solid copper and has a slip-in design. The seat is tapered for a positive gas seal and has six preheat holes for fast starting and cutting. Tip has a heavy preheat.

General purpose tip.

Item#	Tip Size	Type	Series	Pkg. Qty.
12530	2	Acetylene	GW6	1



12538



12607

PUROX STYLE CUTTING TIPS

This cutting tip is a 4202 series with medium heat.

General purpose tip.

Item#	Tip Size	Type	Series	Pkg. Qty.
12532	3	Acetylene	4202	1
12533	4	Acetylene	4202	1
12534	5	Acetylene	4202	1
12535	7	Acetylene	4202	1

SMITH STYLE CUTTING TIPS

Available in 2 types of tips. Both tips have a medium preheat and are used for general cutting. The Acetylene tip is a SC12 series and the Propane/Natural Gas tip is a SC40 series.

Item#	Tip Size	Type	Series	Pkg. Qty.
12536	00	Acetylene	SC12	1
12537	0	Acetylene	SC12	1
12538	1	Acetylene	SC12	1
12539	2	Acetylene	SC12	1
12540	3	Acetylene	SC12	1
12541	4	Acetylene	SC12	1
12606	00	Propane/Natural Gas	SC40	1
12607	0	Propane/Natural Gas	SC40	1
12608	1	Propane/Natural Gas	SC40	1
12609	2	Propane/Natural Gas	SC40	1
12610	3	Propane/Natural Gas	SC40	1
12611	4	Propane/Natural Gas	SC40	1



CUTTING/GOUGING TIP/NOZZLES



12543
Acetylene



12548
Propane & Natural Gas



12556
Acetylene



12562
Propane & Natural Gas

SMITH STYLE CUTTING TIPS

Available in 2 types of tips. Both tips have a medium preheat and are used for general cutting. The Acetylene tip is a MC12 series and the Propane/Natural Gas is an MC40 series.

Item#	Tip Size	Type	Series	Pkg. Qty.
12542	0	Acetylene	MC12	1
12543	1	Acetylene	MC12	1
12544	2	Acetylene	MC12	1
12545	3	Acetylene	MC12	1
12546	4	Acetylene	MC12	1
12547	0	Propane/Natural Gas	MC40	1
12548	1	Propane/Natural Gas	MC40	1
12549	2	Propane/Natural Gas	MC40	1
12550	3	Propane/Natural Gas	MC40	1
12551	4	Propane/Natural Gas	MC40	1

VICTOR STYLE CUTTING TIPS

Available in 2 types of tips. Both tips have a medium preheat and are used for general cutting. The Acetylene tip is a 1-101 series and the Propane/Natural Gas is an GPN series.

Item#	Tip Size	Type	Series	Pkg. Qty.
12552	000	Acetylene	1-101	1
12553	00	Acetylene	1-101	1
12554	0	Acetylene	1-101	1
12555	1	Acetylene	1-101	1
12556	2	Acetylene	1-101	1
12557	3	Acetylene	1-101	1
12558	4	Acetylene	1-101	1
12559	0	Propane/Natural Gas	GPN	1
12560	1	Propane/Natural Gas	GPN	1
12561	2	Propane/Natural Gas	GPN	1
12562	3	Propane/Natural Gas	GPN	1
12563	4	Propane/Natural Gas	GPN	1



12565



12569

VICTOR STYLE ACETYLENE GOUGING TIPS

This is a 1-118 series gouging tip. Used for general purpose gouging, scarfing, weld removal, plate gouging and rivet removal.

Item#	Tip Size	Type	Series	Pkg. Qty.
12564	0	Acetylene	1-118	1
12565	2	Acetylene	1-118	1
12566	4	Acetylene	1-118	1

VICTOR STYLE ACETYLENE WELDING NOZZLE

This is a complete Type W series assembly with mixer. Used for general purpose welding-and preheating.

Item#	Tip Size	Type	Series	Pkg. Qty.
12567	000	Acetylene	Type W	1
12568	00	Acetylene	Type W	1
12569	0	Acetylene	Type W	1
12570	1	Acetylene	Type W	1
12571	2	Acetylene	Type W	1
12572	3	Acetylene	Type W	1
12573	4	Acetylene	Type W	1

TIPS/HEATING/ROSEBUDS/NOZZLES



12578

VICTOR STYLE CUTTING TIPS

Available in 2 types of tips. Both tips have a medium preheat and are used for general cutting. The Acetylene tip is a 3-101 series and the Propane/Natural Gas is a 3-GPN series.

Item#	Tip Size	Type	Series	Pkg. Qty.
12575	000	Acetylene	3-101	1
12576	00	Acetylene	3-101	1
12577	0	Acetylene	3-101	1
12578	1	Acetylene	3-101	1
12579	2	Acetylene	3-101	1
12580	3	Acetylene	3-101	1
12581	4	Acetylene	3-101	1
12582	5	Acetylene	3-101	1
12583	6	Acetylene	3-101	1
12584	000	Propane/Natural Gas	3-GPN	1
12585	00	Propane/Natural Gas	3-GPN	1
12586	0	Propane/Natural Gas	3-GPN	1
12587	1	Propane/Natural Gas	3-GPN	1
12588	2	Propane/Natural Gas	3-GPN	1
12589	3	Propane/Natural Gas	3-GPN	1
12590	4	Propane/Natural Gas	3-GPN	1



12574

VICTOR STYLE ACETYLENE HEATING ROSEBUD ASSEMBLY

This heating rosebud assembly is a MFA series. Used for general purpose heating, bending and straightening.

Item#	Tip Size	Type	Series	Pkg. Qty.
12574	8	Acetylene	MFA	1



12591

VICTOR STYLE ACETYLENE WELDING TIPS

This elbow style, ET series tip replaces the W series. Used for general purpose welding and preheating.

Item#	Tip Size	Type	Series	Pkg. Qty.
12591	000	Acetylene	ET	1
12592	00	Acetylene	ET	1
12593	0	Acetylene	ET	1
12594	1	Acetylene	ET	1
12595	2	Acetylene	ET	1
12596	3	Acetylene	ET	1



12600

VICTOR STYLE ACETYLENE WELDING NOZZLES

This W-1 series is complete with tip and mixer. Used for general purpose welding and preheating.

Item#	Tip Size	Type	Series	Pkg. Qty.
12597	000	Acetylene	W-1	1
12598	00	Acetylene	W-1	1
12599	0	Acetylene	W-1	1
12600	1	Acetylene	W-1	1
12601	2	Acetylene	W-1	1
12602	3	Acetylene	W-1	1
12603	4	Acetylene	W-1	1



12605

VICTOR STYLE ACETYLENE ROSEBUD

This rosebud assembly is a MFA-1 series. Used for general purpose heating, bending and straightening.

Item#	Tip Size	Type	Series	Pkg. Qty.
12604	6	Acetylene	MFA-1	1
12605	8	Acetylene	MFA-1	1



TORCH LINERS/NOZZLES

MIG WELDER TORCH LINERS



12854

Item No.	Style	Fits Marquette	Size.
12854	Steel	M12205 M12206 M12207 M12209 M12210	15 Ft.



12855

FIREPOWER MIG GUN NOZZLES

Item#	Model No.	Size	Pkg. Qty.
FOR 180 AMP GUNS			
12855	FP21-37	3/8" Bore	1
12856	FP21-50	1/2" Bore	1
12857	FP21-62	5/8" Bore	1
12858	FP21-62FAS	5/8" Bore-Arc Spot	1
FOR 250 AMP GUNS			
12866	FP22-50	1/2" Bore	1
12867	FP22-62	5/8" Bore	1
12868	FP22-62FAS	5/8" Bore-Arc Spot	1
FOR 400 AMP GUNS			
12870	FP24A-50	1/2" Bore	1
12871	FP24A-62	5/8" Bore	1
12872	FP22A-62FAS	5/8" Bore-Arc Spot	1

SPOT WELD NOZZLES

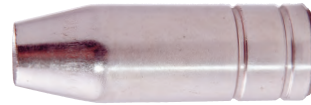

12859

Item#	OEM	Fits Marquette	Size
12859	Binzel	M12179 M12180 M12183	3/8" (16mm)
12848	Binzel	M12179 M12180 M12183	1/2" (12mm)
12849	Binzel	M12204 M12205 M12206 M12207 M12209	5/8" (16mm)
12850	Binzel	M12210 M12209	3/4" (20mm)
12851	Tweco	M12175 M12185 M121801	5/8" (16mm)
12879	MillerMatic	185-M25 Torch	1/2" (12mm)
12880	MillerMatic	185-M15 Torch	1/2" (12mm)



TIPS

MIG WELDER CONTACT TIPS

Solid copper tips thread into diffusers. Match the tip to the wire size. **All tips packaged in 10 per pack.**

BINZEL & TWECO STANDARD TIPS (10 PK)

For All Except M12210



12937

Item#	Tip Size	Size/I.D.
12937	.023	(.6mm)
12938	.030	(.8mm)
12939	.035	(.9mm)
12940	.040	(1mm)

BINZEL & TWECO HEAVY DUTY TIPS (10 PK)

For M12210



12941

Item#	Tip Size	Size/I.D.
12941	.023	(.6mm)
12942	.030	(.8mm)
12943	.035	(.9mm)
12944	.040	(1mm)

BERNARD STANDARD TIPS (10 PK)



12966

Item#	Tip Size	Size/I.D.
12964	.023	(.6mm)
12965	.030	(.8mm)
12966	.035	(.9mm)

HOBART STANDARD TIPS (10 PK)



12967

Item#	Tip Size	Size/I.D.
12967	.023	(.6mm)
12968	.030	(.8mm)
12969	.035	(.9mm)

LINCOLN STANDARD TIPS (10 PK)



12873

Item#	Tip Size	Size/I.D.
12873	.023	(.6mm)
12874	.030	(.8mm)
12875	.035	(.9mm)

MILLER STANDARD TIPS (10 PK)



12877

Item#	Tip Size	Size/I.D.
12876	.023	(.6mm)
12877	.030	(.8mm)
12878	.035	(.9mm)
12882*	.035	(.9mm)

*For Miller 1, 2, and 3 spool guns

FIREPOWER 180 AMP STANDARD TIPS (10 PK)

For All Except M12210



12976

Item#	Tip Size	Size/I.D.
12976	.023	(.031)
12977	.030	(.038)
12978	.035	(.044)
12979	.040	(.048)
12980	.045	(.054)

250/400 AMP GUNS HEAVY DUTY TIPS (10 PK)

For M12210



12981

Item#	Tip Size	Size/I.D.
12981	.023	(.031)
12982	.030	(.038)
12983	.035	(.044)
12984	.040	(.048)
12985	.045	(.054)



Carbide Burs

- ▶ Standard Carbide Burs
- ▶ Mini Carbide Burs
- ▶ Extended Carbide Burs
- ▶ Carbide Bur Sets
- ▶ High Speed Steel Burs
- ▶ Hand Files
- ▶ Rotary Files





CARBIDE BURS

SHARK OFFERS A COMPLETE LINE OF CARBIDE BURS

- Mini Carbide Burs
- Mini Carbide Bur Kits
- Cross References to other Brands
- Attractive Boxes for Kits

ALUMA CUT



Aluma-Cut

Application:

Sometimes described as "Non-Ferrous" this bur is typically used on aluminum, plastics, brass, magnesium or lead.

Features:

Large flutes prevent loading of material or clogging up the flutes with the material you're removing.

DOUBLE CUT



Double

Application:

Sometimes described as "Super Cut" use this bur for general purpose stock removal or deburring of cast iron, steel or other ferrous materials.

Features:

The cross-cut look to the bur acts like rows of teeth producing a fast stock removal as well as offering better control of the work. Excellent in most applications.

DIAMOND CUT



BT14



Diamond

Application:

Typical applications include steel or cast iron where extremely aggressive cutting action is required.

Features:

Deep cross-cut pattern is excellent in tire applications as well as many other uses when cutting extremely hard metals, etc.

MINI CARBIDE BURS WITH 1/8" SHANKS

9 PIECE MINI BUR SET

This 1/8" shank mini carbide bur kit comes with 9 of the most popular shapes to meet all your smaller cutting needs.



16016 / BTM

Item#	Old#	IR#	Shape	Dia. Head	Flute Length	Cut
16016	BTM		9 Piece Bur Kit			
16020	BTM-1	SA51	Cylinder	1/4"	1/2"	Double
16021	BTM-2	SB51	End Cut Cylinder	1/4"	3/16"	Double
16019	BTM-3	SN51	Inverted Cone	1/4"	1/4"	Double
16025	BTM-4	SC51	Rose Nose Cylinder	1/4"	1/2"	Double
16026	BTM-5	SD51	Ball	1/4"	3/16"	Double
16023	BTM-6	SE51	Oval	1/4"	3/8"	Double
16018	BTM-7	SF51	Tree Radius	1/4"	1/2"	Double
16017	BTM-8	SG51	Tree Pointed	1/4"	1/2"	Double
16024	BTM-9	SM51	Cone	1/4"	5/8"	Double

CARBIDE BUR SETS

1/4" SHANK

These burs can be used to cut all types of steel, plastics, ferrous and machinable metals of all kinds. They are designed for use when deburring, removing metal, or enlarging holes and are for use with air tools and grinders. For best results do not put pressure on the burs. Always use protective eyewear when cutting with burs. All burs are double cut or aluma-cut as noted.

Item#	Old#	Description	Pkg. Qty.
16014	BT5	5 Piece Bur Set	
16000	BT14	1/4" Cylinder - Double Cut	1
16004	BT20	3/8" Ball Nose Cylinder - Double Cut	1
16010	BT40	3/8" Tree Radius - Aluma-Cut	1
16011	BT10	1/4" Tree Pointed - Double Cut	1
16022	BT27	1/2" Ball Nose Flame - Double Cut	1



BT10, BT14, BT20, BT27, BT40
16014 / BT5

Item#	Old#	Description	Pkg. Qty.
16015	BT8	8 Piece Bur Set	
16000	BT14	1/4" Cylinder - Double Cut	1
16004	BT20	3/8" Ball Nose Cylinder - Double Cut	1
16005	BT21	1/2" Ball Nose Cylinder - Double Cut	1
16007	BT33	1/2" Ball - Aluma-Cut	1
16010	BT40	3/8" Tree Radius - Aluma-Cut	1
16011	BT10	1/4" Tree Pointed - Double Cut	1
16012	BT24	3/8" Tree Pointed - Double Cut	1
16022	BT27	1/2" Ball Nose Flame - Double Cut	1



BT10, BT14, BT20, BT21, BT24, BT27, BT33, BT40
16015 / BT8

5-PIECE ALUMINUM BUR SET

Item#	Old#	Description	Pkg. Qty.
16027	BT5A	5 Piece Aluminum Bur Set	
16031	BT13	1/4" x 3/4" Cylinder Shape Diamond-Cut	1
16007	BT33	1/2" x 1/2" Ball Aluma-Cut	1
16039	BT35	1/2" x 1" Cylinder Shape Aluma-Cut	1
16040	BT36	1/2" x 7/8" Oval Aluma-Cut	1
16010	BT40	3/8" x 3/4" Tree Shaped Aluma-Cut	1



BT13, BT33, BT35, BT36, BT40
16027 / BT5A



CARBIDE BURS 1/4" SHANK



TREE-SHAPED POINTED CARBIDE BURS

Item#	Old#	IR#	Dia.	Flute Length	Overall Length	Cut
16028	BT9	IRSG-42	1/8"	5/8"	1 1/2"	Double
16011	BT10	IRSG-1	1/4"	5/8"	2"	Double
16012	BT24	IRSG-3	3/8"	3/4"	2 1/2"	Double
16046	BT48	IRSG-5	1/2"	1"	2 3/4"	Double
16076	BT68	IRSG-7	3/4"	1"	3"	Double

TREE-SHAPED RADIUS CARBIDE BURS

Item#	Old#	IR#	Dia.	Flute Length	Overall Length	Cut
16008	BT50	IRSF-1	1/4"	5/8"	2"	Double
16009	BT22	IRSF-3	3/8"	3/4"	2 1/2"	Double
16034	BT23	IRSF-5	1/2"	1"	3"	Double
16047	BT49	IRSF-1NF	1/4"	3/4"	2"	Aluma-Cut
16010	BT40	IRSF-3NF	3/8"	3/4"	2 3/4"	Aluma-Cut
16043	BT41	IRSF-5NF	1/2"	1"	3"	Aluma-Cut



CONE CARBIDE BURS

Item#	Old#	IR#	Dia.	Flute Length	Overall Length	Cut
16049	BT52	IRSM-4	3/8" - 28 deg.	3/4"	2 3/4"	Double
16035	BT25	IRSM-5	1/2" - 35 deg.	7/8"	2 3/4"	Double

BALL NOSED CONE (FLAME) CARBIDE BURS

Item#	Old#	IR#	Dia.	Flute Length	Overall Length	Cut
16013	BT26	IRSL-2	3/8"	1 1/16"	3"	Double
16022	BT27	IRSL-4	1/2"	1 1/8"	3"	Double
16036	BT28	IRSF-6	5/8"	1 5/16"	3 1/4"	Double
16068	BT54	IRSH-2NF	3/8"	3/4"	2 1/2"	Aluma-Cut
16069	BT55	IRSH-5NF	1/2"	1 1/4"	3 1/4"	Aluma-Cut

CARBIDE BURS 1/4" SHANK



CYLINDER-SHAPED CARBIDE BURS

Item#	Old#	IR#	Dia.	Flute Length	Overall Length	Cut
16029	BT11	IRSA-1 LEC	1/4"	5/8"	2"	Dble/End Cut
16031	BT13	IRSA-1 LDia.	1/4"	3/4"	2"	Diamond
16000	BT14	IRSA-1L	1/4"	3/4"	2"	Double
16032	BT15	IRSA-1LD	1/4"	1"	2"	Double
16001	BT16	IRSA-3	3/8"	3/4"	2 3/4"	Double
16002	BT17	IRSA-5	1/2"	1"	3"	Double
16033	BT18	IRSA-6	5/8"	1"	3"	Double
16072	BT58	IRSA-1NF	1/4"	3/4"	1 3/4"	Aluma-Cut
16042	BT38	IRSA-3NF	3/8"	3/4"	2 3/4"	Aluma-Cut
16039	BT35	IRSA-5NF	1/2"	1"	3"	Aluma-Cut
16041	BT37	IRSA-6NF	5/8"	1"	3"	Aluma-Cut



BALL CARBIDE BURS

Item#	Old#	IR#	Dia.	Flute Length	Overall Length	Cut
16075	BT64	IRSD-1	1/4"	7/32"	2"	Double
16006	BT31	IRSD-2	5/16"	1/4"	2 1/4"	Double
16045	BT45	IRSD-3	3/8"	5/16"	2 5/16"	Double
16038	BT32	IRSD-5	1/2"	7/16"	2 7/8"	Double
16067	BT53	IRSD-3NF	3/8"	5/16"	2 5/16"	Aluma-Cut
16007	BT33	IRSC-5NF	1/2"	7/16"	2 1/2"	Aluma-Cut



BT12

CYLINDER-SHAPED ROUTER CARBIDE BUR

Item#	Old#	IR#	Dia.	Flute Length	Overall Length	Cut
16030	BT12	IRSG-33	1/4"	1"	2 1/2"	Diamond



BT19 BT20 BT21 BT57 BT42 BT56

BALL-NOSED CYLINDER CARBIDE BURS

Item#	Old#	IR#	Dia.	Flute Length	Overall Length	Cut
16003	BT19	IRSC-1	1/4"	5/8"	2 1/2"	Double
16004	BT20	IRSC-3	3/8"	3/4"	2 3/4"	Double
16005	BT21	IRSC-5	1/2"	3/4"	3"	Double
16071	BT57	IRSC-1NF	1/4"	3/4"	2"	Aluma-Cut
16044	BT42	IRSC-3NF	3/8"	3/4"	2 1/2"	Aluma-Cut
16070	BT56	IRSC-5NF	1/2"	1"	3"	Aluma-Cut



BT59 BT29 BT36 BT63

OVAL SHAPED CARBIDE BURS

Item#	Old#	IR#	Dia.	Flute Length	Overall Length	Cut
16073	BT59	IRSE-3	3/8"	5/8"	2 5/8"	Double
16037	BT29	IRSE-5	1/2"	7/8"	2 3/4"	Double
16074	BT63	IRSE-3NF	3/8"	5/8"	2 5/8"	Aluma-Cut
16040	BT36	IRSE-5NF	1/2"	7/8"	2 5/8"	Aluma-Cut



EXTENDED CARBIDE BURS

1/4" SHANK

For applications where added length is required, these bur kits come with 6" extended burs in popular 4 or 6 piece kits; as well as a 4 piece all Aluminum Cutting kit.

Perfect for many applications, these burs come in Aluma-Cut or Double Cut.



BTE4



EXTENDED CARBIDE BUR KITS

Item#	Old#	Quantity	Description	Kit Includes
16077	BTE4	4 pieces	Extended Bur Kit	BT20E, BT22E, BT23E, BT32E
16078	BTE6	6 pieces	Extended Bur Kit	BT20E, BT21E, BT22E, BT23E, BT32E, BT43E
16079	BTA4	4 pieces	Aluminum Extended Bur Kit	BT33E, BT40E, BT41E, BT42E

Item#	Old#	Diameter	Shape	Description
16080	BT20E	3/8"	Cylinder/Radius End	Double Cut - 6"
16081	BT21E	1/2"	Cylinder/Radius End	Double Cut - 6"
16082	BT22E	3/8"	Tree Shaped	Double Cut - 6"
16083	BT23E	1/2"	Tree Shaped Radius	Double Cut - 6"
16084	BT32E	1/2"	Ball End	Double Cut - 6"
16085	BT33E	1/2"	Ball End	Aluma-Cut - 6"
16086	BT40E	3/8"	Tree Shaped	Aluma-Cut - 6 3/4"
16087	BT41E	1/2"	Tree Shaped	Aluma-Cut - 7"
16088	BT42E	3/8"	Cylinder/Radius End	Aluma-Cut - 6 3/4"
16089	BT43E	3/8"	Ball End	Double-Cut - 6"

GENERAL PURPOSE FILES / HIGH SPEED STEEL FILES

MULTIPLE USE GENERAL PURPOSE FILES

Multi-purpose files can be used for many different applications. Consisting of the most useful sizes, these are display packaged for ease of retail sale.

Item#	Description	Pkg. Qty.
16050	6" Mill Bastard	1
16051	6" Half Round Bastard	1
16052	6" Round Bastard	1
16053	6" Slim Taper	1
16054	6" Extra Slim Taper	1
16055	8" Mill Bastard	1
16056	8" Half Round Bastard	1
16057	8" Round Bastard	1
16058	8" Slim Taper	1
16059	8" All Purpose File	1
16060	8" x 7/32" Round Chain Saw File	1
16061	8" x 3/16" Round Chain Saw File	1
16062	10" Mill Bastard	1
16063	12" Mill Bastard	1



PLASTIC HANDLE FOR FILE

Replacement plastic handle for files. Comes with adaptors for different shaped files.

Item#	Description	Pkg. Qty.
16064	For 6" - 8" Files	1
16066	For 10" - 12" Files	1



16066

MULTI - PURPOSE ROTARY FILE SET

High quality steel tool set includes:

5 most popular shapes and sizes: Cylindrical, Round Tree, Ball, Cylindrical Ball Nose and 14 Degree Included Angle. Shipped in a plastic reusable case.

Can be used in drill presses, lathes and electrically or air-operated hand or flexible shaft equipment.

Item#	Description	Pkg. Qty.
12950	Multi-purpose rotary file set includes:	1
12952	Round Tree	1
12953	Ball	1
12954	Ball Nose Cylinder	1
12955	14 Degree	1
12957	1/2" Cylinder	1



12950



HIGH SPEED STEEL FILES



ROTARY FILES

Mounted on 1/4" shanks, these files are made from high-speed steel for tough jobs. Most files are 1/2" diameter and can be used on bronze, mild steel, plastic and fiberglass.

Item#	Shape	RPM	Pkg. Qty.
12951	1/4" Cylindrical	2,500	1
12952	Round Tree	2,500	1
12953	Ball	2,500	1
12954	Cylindrical Ball Nose	2,500	1
12955	14 Degree Angle	2,500	1
12956	Flame Rounded	2,500	1
12957	1/2" Cylindrical	2,500	1



ROTARY WOOD RASPS

1/4" shank wood rasps are perfect for hard to reach areas. Used for material removal.

Item#	Shape	RPM	Pkg. Qty.
12959	3/8" Cylinder	2,500	1
12960	1/4" Cylinder	2,500	1
12961	Round Nose Cylindrical	2,500	1
12962	Ball	2,500	1
12963	14 Degree Taper	2,500	1





SHARK INDUSTRIES

Wire Brushes

- ▶ Brass
- ▶ Carbon Steel
- ▶ Stainless Steel
- ▶ Acid Brushes/Tube/Scratch/Cup
- ▶ Crimped
- ▶ Knotted
- ▶ Stringer Bead

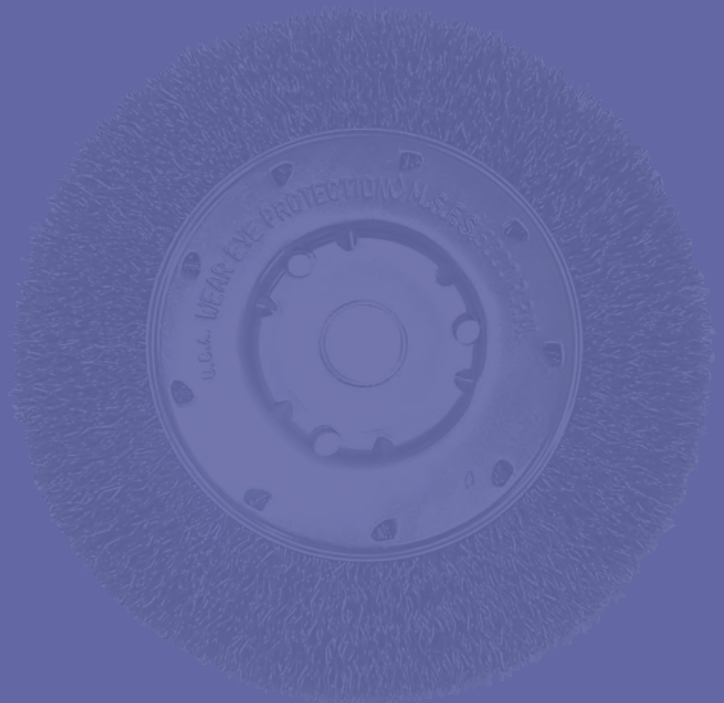



TUBE BRUSHES

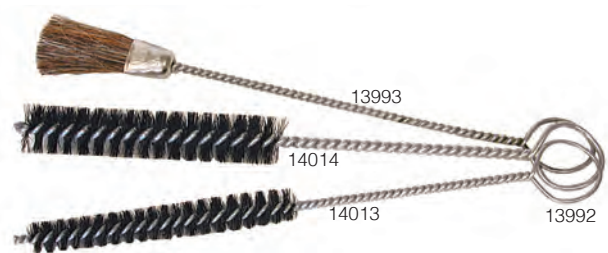
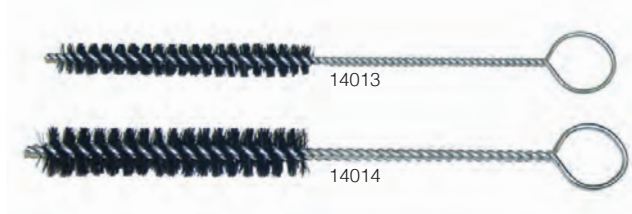

TUBE BRISTLE BRUSHES

Firm bristle brush is 8 1/2" long with 1/2" and 3/4" diameter x 3" nylon bristles. Used for cleaning carburetors, brake cylinders and bottles.

Item#	Description
14013	1/2" Diameter
14014	3/4" Diameter

SPRAY GUN CLEANING BRUSHES

Item#	Description
13992	3 Piece Brush Assortment Includes:
14014	External Cleaning Brush
13993	Fluid Tube Brush
14013	Spray Gun Body Brush

WIRE BRUSHES

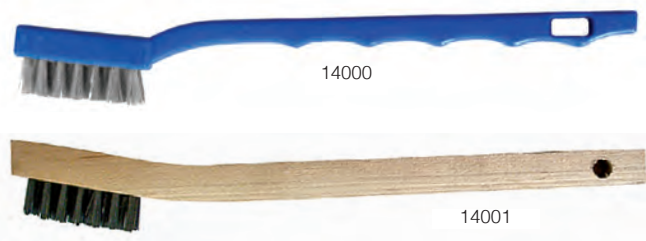

STAINLESS STEEL WIRE BRUSH

Item#	Description
14000	This compact style brush has a plastic 7 1/4" handle and is rustproof. Use for aggressive cleaning action (3 x 7 rows).
14001	This wooden handle brush has stainless steel bristles and a 7 3/4" handle. Used for aluminum welding clean-up (3 x 7 rows).

STAINLESS AND BRASS TINNING BRUSHES

These brushes have a 3/8" x 2 1/2" bristle area and a 8 3/4" handle (2 x 9 row). Great for general cleaning.

Item#	Description
14002	Stainless 8 3/4" x 2x9 rows
14003	Brass 8 3/4" x 2x9 rows



COMPACT BRASS SCRATCH BRUSHES

Brass bristled brushes for use on non-ferrous materials. 7 1/4" (3 x 7 rows). Great for general cleaning.

Item#	Description
14004	Brass/Wooden Handle/Aggressive
14005	Brass/Plastic Handle/Gentle

WIRE BRUSHES



SCRATCH BRUSHES

These brushes have tempered steel, stainless steel, or brass bristles, with a 1/2" x 5" bristle area, and a 4 1/2" plastic handle. 10 1/4" overall length. Great for general cleaning.

Item#	Description
14098	Red Handle/Steel
14099	Yellow Handle/Brass
14141	Green Handle/Stainless Steel



LONG HANDLE "V" BRUSH

The "V" bristle shape of this 13 1/2" 3x14 row brush makes it perfect for corners and other areas after welding. Extremely heavy duty paint/rust removal brush with hundreds of strong bristles.

Item#	Description
17005	Wooden Handled "V" Brush For Channel Cleaning and Welding Applications in tight corners

LONG HANDLE SCRATCH BRUSHES

These are extremely heavy duty paint/rust removal brushes with hundreds of strong bristles imbedded in the handles. Bristle Options.

Item#	Description	Rows
14040	Long Handled Bow Shape Carbon Steel	4 x 19
14006	Long Handled Carbon	3 x 19
14007	Long Handled Carbon w/Scraper	3 x 19
14008	Long Handled Brass	3 x 19
14009	Long Handled Stainless Steel	3 x 19
14010	Shoe Handled Carbon Steel	4 x 16
14011	Shoe Handled Brass	4 x 16
14012	Shoe Handled Stainless Steel	4 x 16
13999	Plastic Handled Carbon Steel	3 x 19



WIRE BRUSHES



14019



14020



14021



14022

CHIPPING HAMMER REPLACEMENT WIRE BRUSH

Item#	Description
14020	4 3/4" x 3/4"

WIRE SOLVENT BRUSHES

Item#	Description
14019	This brush is 5 1/2" long and 1 1/4" wide. Long, wire bristle brush is resistant to solvents where firm bristles are needed.
14021	Parts Cleaning Brush 10 1/2" Length
14022	Deluxe Cleaning Brush 11 1/2" Length



14023

WIRE PARTS CLEANING BRUSH

A wire bristled premium parts cleaning brush with aggressive cleaning action that helps to remove cleaning gasket material and varnish.

Item#	Description
14023	9" Long x 1" Bristle Diameter



14025



14026

ACID BRUSHES

Available in two sizes and used for the application of solder flux to work area.

Item#	Description	Pkg. Qty.
14025	3/8"	3 per Pk.
14026	1/2"	3 per Pk.
14069	2- 14025 and 1-14026 Kit	3 per Pk.
13997	3/8"	144 per Pk.
13998	1/2"	144 per Pk.



14017

PLASTIC HANDLED FITTING BRUSHES

For cleaning copper fittings or plumbing joints prior to soldering. Also effective on corrosive battery cable terminals.

Item#	Description
14017	Plastic Handle 1/2" x 4 3/4"
14018	Plastic Handle 3/4" x 4 3/4"

CIRCULAR AND CUP WIRE BRUSHES 1/4" HEX SHAFT

A general purpose brush with 1/4" hex shaft used with electric drills. Brushes have many applications around the shop and home environments. Coarse brushes are .012" wire and fine brushes are .008".

Item#	Diameter	Style	Wire	Description	Shank
13962	1"	End Brush/Crimped	.012	Coarse	1/4" Hex
13963	1"	End Brush/Crimped	.008	Fine	1/4" Hex
13964	1 1/2"	Crimped-Round	.012	Coarse	1/4" Hex
13965	1 1/2"	Crimped-Round	.008	Fine	1/4" Hex
13966	2"	Crimped-Round	.012	Coarse	1/4" Hex
13967	2"	Crimped-Round	.008	Fine	1/4" Hex
13968	2 1/2"	Crimped-Round	.012	Coarse	1/4" Hex
13969	2 1/2"	Crimped-Round	.008	Fine	1/4" Hex
13970	3"	Crimped-Round	.012	Coarse	1/4" Hex
13971	3"	Crimped-Round	.008	Fine	1/4" Hex
13972	4"	Crimped-Round	.012	Coarse	1/4" Hex
13973	4"	Crimped-Round	.008	Fine	1/4" Hex
13974	2"	Crimped Cup on Stem	.012	Coarse	1/4" Hex
13975	2"	Crimped Cup on Stem	.008	Fine	1/4" Hex
13976	3"	Crimped Cup on Stem	.012	Coarse	1/4" Hex
13977	3"	Crimped Cup on Stem	.008	Fine	1/4" Hex



13971



13962



13975

CIRCULAR AND CUP WIRE BRUSHES 1/4" SHAFT

A general purpose brush used with electric drills. Brushes have many applications around the shop and home environments. Coarse brushes are .020" wire and fine brushes are .014".



14028



14095

Item#	Old#	Size	Style	Wire	Description	RPM
712E		1 1/4"	Crimped Cup on Stem	.014	Fine	13,000
14027	715F	1 1/2"	Crimped-Round	.020	Coarse	6,000
14028	720F	2"	Crimped-Round	.020	Coarse	6,000
14029	725F	2 1/2"	Crimped-Round	.020	Coarse	6,000
14030	730F	3"	Crimped-Round	.020	Coarse	6,000
14031	730SF	3"	Crimped-Round	.014	Fine	4,500
14032	740SF	4"	Crimped-Round	.014	Fine	15,000
14095	715E	1 1/2"	Crimped Cup on Stem	.020	Coarse	13,000
14096	721E	2 1/2"	Crimped Cup on Stem	.020	Coarse	4,500
14097	722E	2 1/2"	Crimped Cup on Stem	.014	Fine	4,500



END BRUSH/CRIMPED WHEEL

END BRUSHES

1/4" SHAFT

For use with a 1/4" diameter air or electric tool, these brushes can get into hard to reach locations. Use on rubber or plastic, rust, weld cleaning, scale removal etc.



Item#	Old#	Size	Style	Wire	RPM
708E		1"	Crimped	.014	22,000
709E		3/4"	Crimped	.006	22,000
720E		1/2"	Crimped	.006	22,000
14024	711E (SS)	1"	Crimped	.020	20,000
14070	713E	3/4"	Crimped	.020	20,000
14071	710E	1"	Crimped	.020	20,000
13988	(SS)	1"	Knotted	.020	20,000
14072	711F	3/4"	Knotted	.020	20,000
14073	718E	1"	Knotted	.020	20,000
719E		1"	Knotted	.014	20,000
14074	714E (SS)	1 1/4"	Knotted	.020	20,000



CIRCULAR CRIMPED WHEEL

Choose between a 3" or 4" diameter with a 1/2" arbor .008" wire

Item#	Size	RPM
14034	3"	4,500
14035	4"	4,500



ENCAPSULATED WIRE WHEEL

3" Plastic encapsulated wire wheel on 1/4" Mandrel

Item#	Size	RPM
13961 Hex Mandrel	3"	4,500
13979 Round Mandrel	3"	4,500



MINI KNOTTED WIRE BRUSHES

Mini Knotted Circular Wire brush with 1/4" Mandrel.

Item#	Size	Wire	RPM
13995	2"	.020	7,500
13996	3"	.020	12,500

CRIMPED WIRE/KNOTTED CUP BRUSHES



14033

CRIMPED WIRE TIRE BRUSHES

Heavy duty 3" diameter cup brush for rim/hub cleaning. .016" Brass coated wire.

Item#	Size	Arbor	Wire	RPM
14033	3"	1/4" Hex Shank	.016	10,000



14077

CRIMPED WIRE CUP BRUSHES

For use in cleaning metal parts and hard surfaces in hard to reach places. Use with angle grinders. Always follow correct speed ratings.

Item#	Old#	Size	Arbor	Wire	RPM
14075	735C	3"	1/2"-13	.014	12,500
14076	730C	3"	5/8-11NC	.014	12,500
14077	723C	3"	M10 x 1.25	.020	12,500
14078	725C	3"	M10 x 1.50	.014	12,500
14079		3"	M14 x 2.0	.014	12,500
14080	740C	4"	5/8-11NC	.014	9,000
14081	750C	5"	5/8-11NC	.020	6,600
14082	760C	6"	5/8-11NC	.020	6,500



14049

DOUBLE ROW KNOTTED WIRE CUP BRUSHES

Extremely durable and aggressive. Use with an appropriate size angle grinder.

Item#	Old#	Size	Arbor	Wire	RPM
14049		4"	5/8-11NC	.014	9,000
14050		5"	5/8-11NC	.014	7,000
14051		6"	5/8-11NC	.014	6,500



14043

SINGLE ROW KNOTTED CUP BRUSHES

Available with standard or metric arbor sizes in various diameters. Use for general cleaning, welding and removal of paint and rust. Use with angle grinders.

Item#	Old#	Size	Arbor	Wire	RPM
14041	723K	3"	1/2"-13	.020	12,500
14042	730K	3"	5/8-11NC	.014	12,500
14043	722K	3"	5/8-11NC	.020	12,500
13991	Stainless Steel	3"	5/8-11NC	.014	12,500
14044	724K	3"	M10 x 1.25	.020	12,500
14045	725K	3"	M10 x 1.50	.014	12,500
14046		3"	M14 -2.0	.020	12,500
14047	740K	4"	5/8-11NC	.020	9,000
13989	Stainless Steel	4"	5/8-11NC	.020	9,000
14048	760K	6"	5/8-11NC	.020	6,500
13990	Stainless Steel	6"	5/8-11NC	.020	6,500



14058

CRIMPED WIRE WHEELS

Choose from 4" to 10" diameters with .014" wire size.

Item#	Old#	Size	Arbor	RPM
14052		4"	5/8-11NC	8,500
14053		4"	M10-1.25	12,500
14054		4"	M10-1.50	12,500
14056		4"	M14-2.0	12,500
14057	762S	6" Narrow Width	1/2" - 5/8"	6,000
14058	767S	6" Medium Width	1/2" - 5/8"	6,000
777S		7"	1/2" - 5/8"	6,000
14059	780S	8"	1/2" - 5/8"	4,500
14140		10"	1 1/4"	3,600



WIRE WHEEL BRUSHES

TWIST KNOTTED WIRE WHEEL BRUSHES

These brushes are available with standard center thread sizes with a width of 5/16" and .020 wire. Use on hard materials for general purpose cleaning and polishing.

Item#	Old#	Size	Wire	Wire Type	Arbor	RPM
14064	743S	4"	.020	Steel	5/8-11NC	20,000
14065		4"	.020	SS	5/8-11NC	20,000
13980		4 1/2"	.020	Steel	5/8-11NC	12,500
13981		4 1/2"	.020	SS	5/8-11NC	12,500
14130		5"	.020	Steel	5/8-11NC	12,500
14134		5"	.020	SS	5/8-11NC	12,500
14066		6"	.020	Steel	5/8-11NC	9,000
14067		6"	.020	SS	5/8-11NC	9,000
13982		7"	.020	Steel	5/8-11NC	9,000
13983		7"	.020	SS	5/8-11NC	9,000



14064

KNOTTED WIRE WHEEL BRUSHES WITH ADAPTORS

These brushes are available with standard or metric center thread sizes with a width of 5/16" and .014 to .020 wire. Use on hard materials for general purpose cleaning and polishing.

Item#	Old#	Size	Wire	Style	Arbor	RPM
14060	748S	4"	.014	Knotted	1/2"-3/8"	20,000
14061		4"	.014	Knotted	M10-1.25	20,000
14062		4"	.014	Knotted	M10-1.50	20,000
14063		4"	.014	Knotted	M14-2.0	20,000
14068		6"	.020	Knotted	5/8"-1/2"	9,000
760S		6" Full Cable	.014	Full Cable	1/2", 5/8"	6,000
787S		8"	.014	Knotted	1/2", 5/8"	9,000



14068

STRINGER BEAD TWIST WIRE WHEEL BRUSHES

These brushes are available with standard or metric arbor sizes and .020" heavy duty wire. Used for aggressive cleaning.

Item#	Old#	Size	Wire	Wire Type	Arbor	RPM
13984		4 1/2"	.020	Steel	5/8-11NC	12,500
13985		4 1/2"	.020	SS	5/8-11NC	12,500
13986		7"	.020	Steel	5/8-11NC	9,000
13987		7"	.020	SS	5/8-11NC	9,000
14083		4"	.020	Steel	1/2" - 13	20,000
14084	744S	4"	.020	Steel	5/8-11NC	20,000
14085		4"	.020	SS	5/8-11NC	20,000
14086		4"	.020	Steel	M10 -1.25	20,000
14087		4"	.020	Steel	M10 -1.25	20,000
14088		4"	.020	Steel	M14 -2.0	9,000
14089		5"	.020	Steel	5/8-11NC	12,500
14138		5"	.020	SS	5/8-11NC	12,500
14128	745S	6"	.020	Steel	5/8-11NC	9,000
14139		6"	.020	SS	5/8-11NC	9,000



14083

LUG BRUSH/ARBOR ADAPTORS



CABLE LUG CLEANING BRUSH

This brush will clean an I.D. of 1/2", 5/8" and 7/8" fittings. It will also do an O.D. of 1/2", 5/8" and 7/8" tubing. This brush is great for cleaning rust off battery terminals. Use it to clean and scratch the ID of tubing in plumbing and building applications.

Item#	Description	Length
14155	Double sided cleaning brush	7 3/4" Long



ADAPTOR KIT

This adaptor kit will start with a 2" hole on your wire wheel and adapt it from 1/2"-5/8"-3/4"-1". Kit includes center telescoping adaptors and 2 arbor rings.

Item#	Description
14136	For 3/4" thick wheels



ARBOR ADAPTOR

These adaptors are available with various arbor sizes and a 2" outside diameter with plain hole centers. Use for mounting wire wheels to bench grinders.

Item#	Description	Size
14090	Set of 2	1/2"
14091	Set of 2	5/8"
14092	Set of 2	3/4"



ADAPTOR NUTS

Nuts adapt 5/8 - 11 arbor brushes to fit M10-1.25 and 1.50 high speed grinder spindles.

Item#	OD Size	I.D. Size
14093	5/8-11 NC	M10 - 1.25
14094	5/8-11 NC	M10 - 1.50
14129	5/8-11 NC	3/8" - 24 NF



Welding Displays

Sales Solutions

Item#	Description
17000	Welding 4' x 5' Planogram
17001	Welding 4' x 5' Planogram
17002	Welding 8' x 5' Planogram
17003	Small 2 Way Welding Display
17003N	Small Display Without Rack
17004	Large 4 Sided Welding Display
17004N	Large Display Without Rack
17004R	Large 4 Sided Welding Display- Rack Only
17007	Replenishing Kit for 17003 and 17004 Displays

Shark has the perfect formula for successful sales. Our welding planograms and display racks carry the most popular, up-to-date consumable products with tri-lingual, 4 color packaging. Included in the assortments are Abrasives, Wire Wheels, Rod, Wire, Electrode Holders, Cutting Tips, Mig Tips, Cutting Kits (on some), Helmets, and Welding Hose.

Request our display brochure for a more complete listing by part number, or view it online at www.sharkind.com



Welding Displays

- ▶ Planograms
- ▶ 2-Sided Freestanding Displays
- ▶ 4-Sided Freestanding Displays



SHARK INDUSTRIES

Paint and Body

- ▶ Erasers
- ▶ Scrapers
- ▶ Dust Masks
- ▶ Razor Blades
- ▶ Body Shop Tools
- ▶ Sprayer Tips
- ▶ Pistol Vac
- ▶ Blow Guns
- ▶ Blending Hammer
- ▶ Dolly Sets

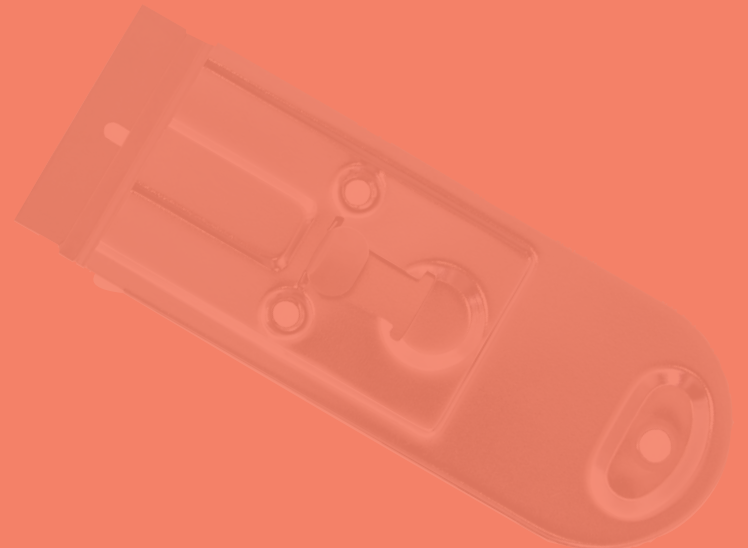



AUTO BODY TOOLS



18061

4" AUTO BODY PIN STRIPE ERASER

Quick, effective removal of pin striping without paint damage! Has an effective spoke design, and is available with mandrel and eraser only for added cost savings.

4" Diameter x 11/16" thick.

Item#	Description
18060	Eraser only
18061	Eraser and Mandrel with threaded adaptor
18062	Mandrel Only



60

ALL PURPOSE SCRAPER

3-Position multi-use scraper is ideal for Sticker and Decal removal.

Item#	Description
60	All Purpose Scraper



61

RETRACTABLE SCRAPER

Retractable blade for ease and portability

Item#	Description
61	Retractable scraper



65

RAZOR BLADES

A box of 100 American Made Razor Blades for all your needs. A must for every body shop!

Item#	Description
65	Pack of 100 razor blades
65-10	Pack of 10 razor blades

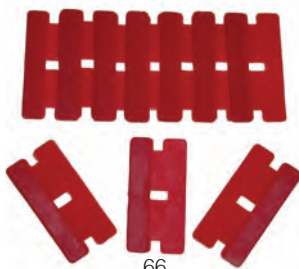

66

PLASTIC RAZOR BLADES

For use on GM cars with plastic coated windows. Also used for oversprays and wherever any painted surface needs to be cleaned.

Item#	Description
66	10 pack of plastic blades
66-100	100 box of plastic blades



66H

RETRACTABLE SCRAPER WITH 3 PLASTIC BLADES

The above plastic blades combined with our most popular scraper.

Item#	Description
66H	Retractable Scraper with 3 plastic blades

UNIVERSAL MOLDING RELEASE TOOL

Used in cemented and rear windshields.

Item#	Description
51	Universal Molding Release Tool



51

TRIM PAD REMOVING TOOL

Facilitates removal of plastic trim pad fasteners without damaging the fastener or the backboard.

Item#	Description
52	Trim Pad Removing Tool

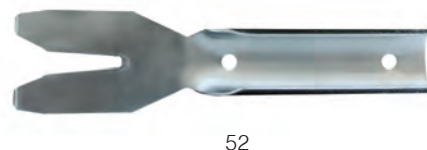

52

DOOR HANDLE CLIP TOOL

For door handles and window regulator clips. Eliminates upholstery damage.

Item#	Description
53	Door Handle Clip Tool

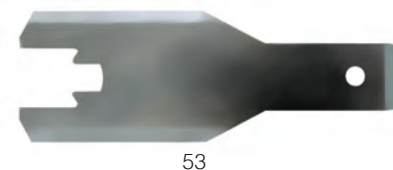

53

DOOR AND WINDOW HANDLE CLIP TOOLS

Reversible tool handles all GM cars, as well as most foreign.

Item#	Description
54	Door and Window Handle Clip Tools

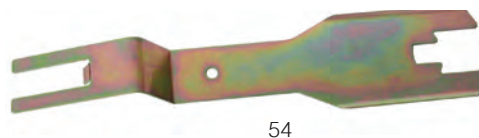

54

STUBBY BODY PANEL 1/8" DRILL BITS

High Speed Steel drill bits for use on sheet metal. 135 degree split point for fast drilling without center punching.

Item#	Description
76	Pouch of 12 Double Ended Bits



76

3/8" DOUBLE ENDED SPOT WELD CUTTER

Removes spot welds without damage to underlying panels. Invaluable to auto body restoration.

Item#	Description
10060	3/8" Double Ended Cutter with Special Tip Design
10059	3/8" Double Ended Replacement Cutter

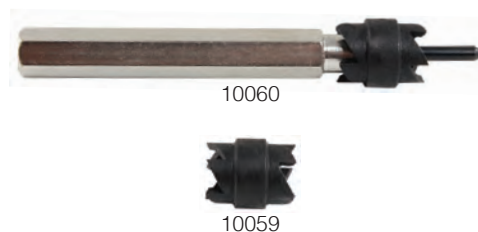

10060

10059



AUTO BODY TOOLS

SHARK PISTOL VAC

Turns any Shop Air into a powerful Vacuum Cleaner or Air Cleaning Gun!

Designed for high powered industrial vacuum cleaning with air pressure, the Pistol Vac connects to your air line and can be used in many applications in the vacuum mode or blow mode.

Vacuum Cleaning Power with Shop-Air!

- Out performs inexpensive imports
- Dust bag and Crevice Tool included
- No electrical connection needed
- Fits many PBE applications
- Easy and Convenient to use
- Simple construction is maintenance free
- Inexpensive and quiet

Item#	Description
64000	Pistol Vac w/ Bag and Crevice Tool
64001	Crevice Tool
64002	Vacuum Bag
64003	3' Hose Section
64004	8' Hose Section
64005	Brush
64006	20" Extension Tube
64007	2" Diameter Fitting for Steel Drum
64008	Replacement Trigger



64000

Picks up:

- Glass
- Sawdust
- Metal Chips
- Dust Spills

SHARK QUICK SPRAY TIP

The simple tip can transform most type blow guns into a convenient sprayer. It snaps easily and quickly onto the tip of the gun. Available with or without vinyl hose.

Use when spraying a variety of liquids!

- Cleaning solution
- Undercoating
- Brake cleaners
- Solvents/Gunk

Works with all Vacula, Snap-on, Mac, Matco, Shark and NAPA type blow guns!

Item#	Description
S3660	Tip with 6' Vinyl Hose
S3665	Tip Alone
S3670	6' Vinyl Hose

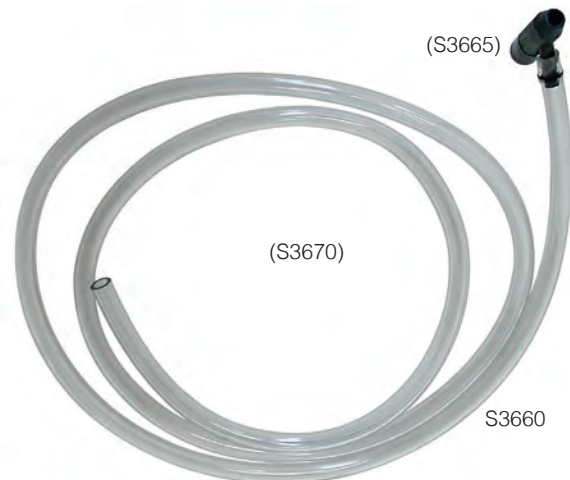

(S3665)

(S3670)

S3660

STANDARD BLOW GUNS

- Insulated Grip with Comfortable Design
- An assortment of sizes in outlet tubes
- A wide variety of safety conscious, interchangeable nozzles
- Infinite variable flow control
- Multi-use as well as fluid dispensing
- OSHA approved tips

Item#	Description
S1050A	Full Flow Blow Gun
S1060A	Full Flow Blow Gun with Rubber Tip
S1150A	13" Full Flow Blow Gun
S1250A	20" Full Flow Blow Gun



RUBBER TIP FOR SPECIAL APPLICATIONS

Non-scratching rubber-tipped adaptor fits on the gun and allows you to use it in holes or for blowing out cylinders, pistons, etc. when working on any mechanical job.

Item#	Description
S4010	Rubber Tip



OSHA BY-PASS TIP

OSHA approved tip is placed on the end of the blow gun and has side vents towards the top that increase the air velocity as it leaves the tip. The tip is OSHA approved as the air flows out through these vents if placed against your hand.

Item#	Description
S4020	OSHA By-Pass Tip



CHIP SHIELD

Chip Shield prevents chips or particles from blowing back in your face when using the blow gun. Also makes the gun OSHA approved as the air flows out the sides if placed against your hand.

Item#	Description
S4030	Chip Shield

ALUMINUM BLENDING HAMMER

- Lightweight aluminum hammer is suitable for dent removal of aluminum body repairs
- Four interchangeable Polyoxymethylene tips, stored inside the handle, are available for different applications

Item#	Description
13284	Aluminum Blending Hammer with 4 POM Tips
13285	Aluminum Blending Hammer (no tips)
13286	Ball Tip
13287	Mushroom Head
13288	Blunt Tip
13289	Sharp tip





ALUMINUM AUTO BODY TOOLS

7 PIECE RUBBER COATED DOLLY SET

- This rubber dolly set works well in recessed or sharp corners and wide radii. Also works well on lighter metal sheets and panels. They help return the metal to its original shape.
- The weighted hard rubber coating allows for a cushion effect to match the hammer without stretching the metal and damaging the car body paint, suitable for aluminum body repairs.
- Drop forged steel construction for long life. They are used behind any sheet metal you are using a hammer on.

Item#	Description
13260	7 Piece Rubber Coated Dolly Set
13261	Heel Dolly
13262	Long Type Heel Dolly
13263	Double End Dolly
13264	Curved Dolly
13265	Utility Dolly (General Purpose)
13266	Double End Hand Dolly
13267	Long Type Curved Dolly

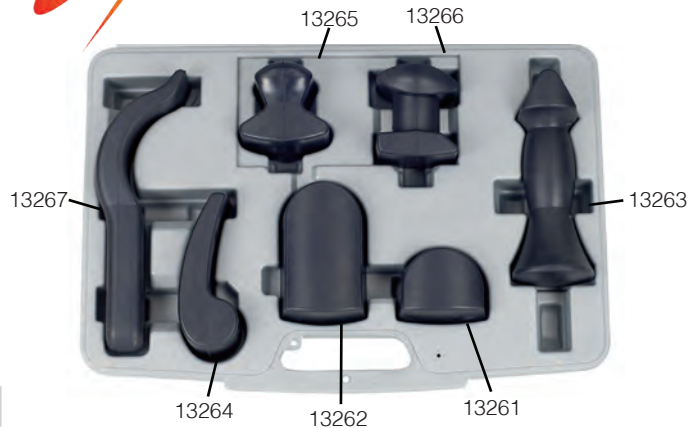

13260 Contents: heel dolly, long type heel dolly, double end dolly, curved dolly, utility dolly, double end hand dolly, long type curved dolly. Comes in blow mold case.

12 PIECE DOLLY SET

- Suitable for aluminum body repairs
- Works well in recessed corners, sharp corners, and wide radii
- Made of Polyoxymethylene and non-marking when impacting against metal

Item#	Description
13270	12 Piece POM Dolly Set
13271	Double End Dolly
13272	Round Head Chisel Dolly
13273	Bolster Head Dolly
13274	Crease Alignment Tool
13275	Profile Arranging Block I & II
13276	Hand Fist Flat & Curved Dolly
13277	Large Toe Dolly
13278	Heel Dolly
13279	General Purpose Dolly
13280	Block Dolly
13281	Curved Dolly
13282	Wedge Dolly

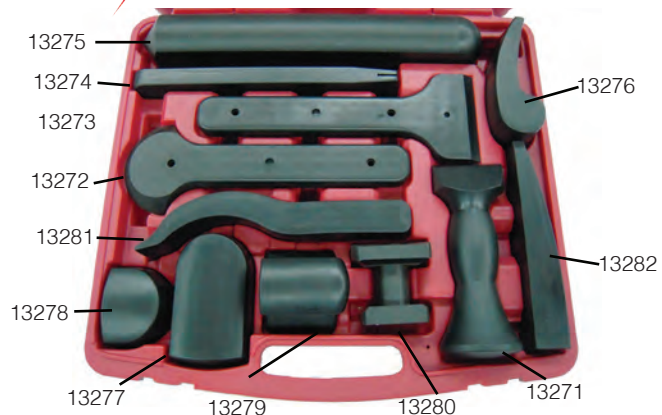

13270 Contents: double end dolly, round head chisel dolly, bolster head dolly, crease alignment tool, profile arranging block I + II, hand fist flat+curved dolly, large toe dolly, heel dolly, general purpose dolly, block dolly, curved dolly, wedge dolly. Comes in blow mold case.

WALNUT SHELL BLASTING MEDIA

All natural, real walnut shells are used as a blasting media for the removal of surface contaminants without damaging the base metal. Available in Medium Grit. USA made.

- For blasting intake valves to remove carbon build-up
- Use on Audi, BMW and Minis for manifold intake cleaning
- Safely removes carbon without damaging engine
- Made in USA



Item#	Description	Grit	Weight
13076	Walnut Shell Blasting Media	Medium	25 lbs.



GLASS BEAD BLASTING MEDIA

Glass beads are used as blasting media for a variety of applications. Available in Coarse and Medium Grits. USA Made.

- Removes:
 - Surface Rust
 - Debris and Corrosion
 - Paint in Auto Body Applications
- Made in USA



Item#	Description	Grit	Weight
13077	Glass Bead Blasting Media	Coarse	25 lbs.
13078	Glass Bead Blasting Media	Medium	25 lbs





3M/FIREPOWER/FORNEY/SHARK CROSSOVER

3M	Shark	Firepower	Shark	Firepower	Shark	Firepower	Shark	Firepower	Shark	Firepower	Shark
01396	12614	0387-0136	12556	1423-1420	12220	1423-2224	12957	1440-0097	11021	1443-0002*	12300
01397	12613	0387-0144	12576	1423-1421	12221	1423-2225	12952	1440-0098	11022	1443-0003*	12303
01398	12612	0387-0145	12577	1423-1422	12202	1423-2226	12953	1440-0105	11014	1443-0004*	12309
01406	12618	0387-0146	12578	1423-1423	12245	1423-2227	12954	1440-0106	11015	1443-0005*	12315
01407	12617	0387-0147	12579	1423-1424	12250	1423-2228	12955	1440-0107	11016	1443-0015	12100
01408	12616	0387-0172	12559	1423-1425	12251	1423-2229	12950	1440-0108	11017	1443-0016	12101
01410	9989	0387-0173	12560	1423-1426	12252	1423-2232	12750	1440-0115	11009	1443-0026	12106
01411	9989-12	0387-0182	12585	1423-1428	12256	1423-2234	14074	1440-0116	11010	1443-0027	12107
01987	26-10	0387-0184	12587	1423-1432	12222	1423-2237	12726	1440-0117	11011	1443-0035	12226
01988	25-10	0387-0185	12588	1423-1435	12201	1423-2238	12728	1440-0118	11012	1444-0025	12976
01989	26SL	0387-0487	12242	1423-1442	14012	1423-2271	12787	1440-0124	11034	1444-0026	12977
01990	25SL	0387-1227	12501	1423-1452	14017	1423-2272	12788	1440-0125	11035	1444-0027	12978
01991	38SL	0387-1228	12532	1423-1459	14019	1423-2274	12790	1440-0126	11036	1444-0028	12979
02145	13144	0387-1229	12533	1423-1459	14019	1423-2275	12791	1440-0127	11037	1444-0029	12980
05001	12997	0387-1233	12538	1423-2100	14027	1423-2310	12772	1440-0134	11029	1444-0050	12855
05002	12991	0387-1234	12539	1423-2101	14028	1423-2310	12772	1440-0134	11029	1444-0050	12855
05006	12990	0387-1236	12543	1423-2102	14030	1423-2311	12771	1440-0135	11030	1444-0051	12856
05008	12989	0387-1237	12544	1423-2103	14031	1423-2312	12773	1440-0136	11031	1444-0052	12857
05010	12987	0387-1237	12544	1423-2104	14070	1423-2327	14052	1440-0137	11032	1444-0053	12858
05539	323T	0387-1238	12545	1423-2105	14072	1423-3135	12928	1440-0145	11024	1444-0170	12854
05540	333T	1412-0012	12263	1423-2106	14025	1423-3136	12909	1440-0146	11025	1444-0220	12981
05541	343T	1412-0020	12265	1423-2107	N/A	1423-3137	12910	1440-0147	11026	1444-0221	12982
07447	13017	1412-0021	12270	1423-2108	14097	1423-3142*	12702	1440-0148	11027	1444-0222	12983
07450	640TPDB-25	1412-0022	12271	1423-2109	14076	1423-3143*	12704	1440-0151	11050	1444-0223	12984
07451	642TPDB-25	1420-0293	16100	1423-2110	14042	1423-3144*	12708	1440-0152	11051	1444-0224	12985
07453	620TPDB-25	1420-0295	12261	1423-2111	14083	1423-3145*	12712	1440-0155	11118	1444-0407	14483
07453	620TPDB-25	1421-0038	14480	1423-2112	14128	1423-3146*	12714	1440-0156	11119	CSMC121	12543
07453	620TPDB-C	1421-0062	12050	1423-2113	14064	1423-3147*	12716	1440-0165	11115	CSMC122	12544
07455	630TPDB-25	1423-0001	14401	1423-2114	14081	1423-3148*	12722	1440-0181	11065	CSMC123	12545
07455	630TPDB-C	1423-0016	12241	1423-2115	14047	1423-3149*	12700	1440-0182	11066	CSSC121	12538
07456	632TPDB-25	1423-0017	14308	1423-2116	14048	1423-3150*	12710	1440-0183	11067	CSSC122	12539
07456	632TPDB-C	1423-0018	14309	1423-2117	14071	1423-3151*	12731	1440-0185	11059	Forney	Shark
07457	622TPDB-25	1423-0019	14302	1423-2118	14073	1423-3152*	12732	1440-0186	11060	1687	12403
07457	622TPDB-C	1423-0020	14300	1423-2119	14066	1423-3153*	12734	1440-0187	11061	1702	Disc.
07480	620TBC	1423-0026	12237	1423-2120	14068	1423-3154	12702	1440-0188	11062	1705	12405
07481	622TB	1423-0032	12238	1423-2121	14058	1423-3155	12704	1440-0195	11054	1720	12407
07482	640TB-10	1423-0050	12239	1423-2122	14057	1423-3156*	12712	1440-0196	11055	1753	Disc.
07483	642TB-10	1423-0051	14402	1423-2122	14057	1423-3157*	12716	1440-0197	11056	1754	12411
07485	630TB	1423-0052	12240	1423-2123	14059	1423-3157*	12716	1440-0197	11056	1754	12411
07486	632TB	1423-0081	14002	1423-2124	14093	1423-3158	14080	1440-0200	11044	12761	12834
07492	343	1423-0082	14009	1423-2125	14094	1423-3159	14137	1440-0201	11045	36062	12015
07493	333	1423-0083	14010	1423-2126	14043	1423-3161	14136	1440-0202	11046	37025	Disc.
07494	323	1423-0084	14000	1423-2127	14084	1423-3162	45836	1440-0203	11047	37028	12254
07511	644TB	1423-0085	12112	1423-2136	12929	1423-3163	45838	1440-0205	11039	37030	12254
07512	646TB	1423-0086	12111	1423-2137	12930	1423-3164	45840	1440-0206	11040	37031	12253
07513	634TBC	1423-0087	14006	1423-2138	12931	1423-3165	45841	1440-0207	11041	37101	12041
07514	636TBC	1423-0088	12213	1423-2140	13006	1423-3166	45842	1440-0210	12000	37250	12040
07515	624TBC	1423-0089	12216	1423-2141	13007	1423-3167	45843	1440-0211	12001	38060	12017
07516	626TBC	1423-0092	14020	1423-2142	13008	1423-3168	45844	1440-0212	12051	38061	12016
19484	6202	1423-0093	14026	1423-2143	13013	1423-3169	45845	1440-0215	12002	38062	12015
19344	6302	1423-0094	12212	1423-2151	12921	1423-3171	12925	1440-0216	12003	38070	12029
Firepower	Shark	1423-0095	12215	1423-2152	12922	1423-3177	12959	1440-0217	12004	38071	12028
0323-0360	12599	1423-0096	12211	1423-2153	12923	1423-3178	12961	1440-0220	12005	38072	12027
0323-0361	12600	1423-0097	12214	1423-2154	12918	1423-3180	12960	1440-0221	12006	38073	12026
0323-0362	12601	1423-1100	14135	1423-2155	12919	1423-3181*	12700	1440-0222	12007	38101	12025
0323-0363	12602	1423-1101	14135	1423-2156	12920	1423-3182*	12710	1440-0230	12008	38102	Disc.
0324-0112	12605	1423-1102	12025	1423-2157	13110	1423-3184	12722	1440-0231	12021	38103	12024
0324-0150	12569	1423-1103	12033	1423-2158	13111	1423-3185	454	1440-0235	12009	38106	Disc.
0324-0151	12570	1423-1105	12032	1423-2159	12917	1423-3208*	12706	1440-0236	12010	38107	12031
0324-0152	12571	1423-1107	12030	1423-2160	12912	1423-3209*	12706	1440-0240	12011	38108	12035
0324-1053	12572	1423-1108	12024	1423-2161	12913	1423-4103	14212	1440-0241	12012	38109	11034
0324-1054	12573	1423-1109	12023	1423-2162	12914	1423-4107	14207	1440-0245	12013	38115	11036
0330-0002	12557	1423-1110	12026	1423-2164	12820	1423-4118	14210	1440-0296	12254	38125	12038
0330-0007	12558	1423-1112	12027	1423-2165	12821	1423-4119	14323	1440-0297	12253	38140	14025
0330-0620	12554	1423-1113	12028	1423-2166	12822	1423-4120	14324	1440-0402	11125	40301	11024
0330-0621	12555	1423-1115	12015	1423-2167	12823	1423-4123	14326	1440-0406	11028	40305	11025
0330-0622	12556	1423-1116	12016	1423-2170	12833	1423-4124	14200	1440-0411	11093	40350	11027
0330-0623	12557	1423-1117	12017	1423-2171	12834	1423-4125	14330	1440-0419	11096	40401	11029
0330-0624	12558	1423-1120	12018	1423-2172	12835	1423-4126	14321	1440-0420	11098	40405	11030
0331-0016	12580	1423-1205	12108	1423-2173	12836	1423-4127	14322	1440-0423*	11090	40410	11031
0331-0017	12581	1423-1206	12224	1423-2174	12837	1423-4128	14400	1440-0424	11090	40450	11032
0331-0179	12576	1423-1207	12235	1423-2177	12702	1423-4131	14506	1440-0425	11088	40501	11034
0331-0180	12577	1423-1212	12236	1423-2178	12703	1423-4132	14507	1440-0427*	11101	40505	11035
0331-0181	12578	1423-1213	12237	1423-2185	12935	1423-4133	14403	1440-0428*	11102	40510	11036
0331-0182	12579	1423-1216*	12230	1423-2186	12731	1423-4134	14452	1440-0429	11107	40550	11037
0331-0183	12580	1423-1217	12232	1423-2187	12732	1423-4135	14453	1440-0430	11108	40680	11068
0331-0184	12581	1423-1219*	12233	1423-2188	12744	1423-4136	14454	1440-0431	11107	40681	11069
0333-0305	12557	1423-1220*	12233	1423-2189	12737	1423-4137	14455	1440-0432*	11104	40683	11071
0333-0402	12580	1423-1300	12284	1423-2190	12746	1423-4138	14456	1440-0433*	11105	40684	11073
0333-0408	12564	1423-1304*	12288	1423-2191	12738	1423-4145	14202	1440-0434	11097	40685	11074
0333-0409	12565	1423-1305*	12287	1423-2192	12748	1423-4146	14112	1440-0441	11013	40686	11075
0333-0550	12585	1423-1310	12281	1423-2193	12739	1423-4157	14500	1440-0442*	11104	40687	11076
0333-0551	12586	1423-1311	12280	1423-2194	13205	1423-4158	14404	1440-0443	11086	40688	11078
0333-0552	12587	1423-1314	12273	1423-2195	13206	1423-4173	14303	1440-0445*	12012	40689	11079
0333-0553	12588	1423-1315	12272	1423-2197	12726	1423-4175	14319				

FORNEY/SHARK CROSSOVER

Forney	Shark	Forney	Shark	Forney	Shark	Forney	Shark	Forney	Shark	Forney	Shark
41150	11012	55910	Disc.	70221	Disc.	71754	12810	72302	13211	86791	12537
41201	11014	55971	14427	70225	12217	71755	12811	72303	13207	86792	12538
41205	11015	55984	14425	70226	12218	71757	12819	72317	12724	86793	12539
41210	11016	55991	14422	70227	12219	71758	12820	72322	13205	86794	12540
41250	11017	56000	12100	70228	12220	71759	12821	72323	13206	86801	12542
41301	11019	56200	12101	70229	12221	71760	12822	72325	14050	86802	12543
41305	11020	56205	12103	70301	12223	71761	12823	72327	14049	86803	12544
41310	11021	56800	14206	70326	16051	71762	12824	72328	14051	86804	12545
41350	11022	56801	14208	70365	16050	71763	12825	72329	14071	86810	12547
42001	11039	56900	14221	70367	16052	71765	12826	72330	14073	86811	12548
42005	11040	56901	14223	70368	16053	71766	12827	72331	14066	86812	12549
42050	11042	57005	14200	70369	16054	71767	12828	72332	14068	87109	12506
42101	11044	57008	14201	70371	16055	71768	12829	72335	14057	87110	12507
42105	11045	57009	14202	70372	16056	71769	12830	72336	14058	87111	12508
42110	11046	57010	14203	70373	16057	71770	12831	72338	14059	87112	12509
42150	11047	57011	14204	70374	16058	71771	12832	72341	12726	87113	12510
42210	11051	57012	14205	70375	16060	71780*	12702	72343	12696	87119	12512
42205	11050	57050	14211	70376	16061	71786*	12708	72345	12728	87120	12513
42210	11051	57051	14212	70377	16059	71798	12730	72347	12698	87121	12514
42250	11052	57052	14213	70378	16064	71803	12924	72352	12727	87122	12515
42276	12004	57053	14214	70379	Disc.	71804	12925	72354	12697	87123	12516
42281*	12007	57054	14215	70385	16062	71805	12926	72356	12729	87131	12526
42285	12001	57055	14216	70386	16063	71806	12927	72358	12699	87200	12518
42286	12003	57056	14217	70469	14014	71818	12750	72363	14090	87201	12519
42287*	12006	57060	14209	70470	Disc.	71819	12751	72364	14091	87202	12520
42290	12000	57061	14210	70471	14017	71820*	12731	72365	14092	87203	12521
42291	12002	57070	14218	70472	14018	71821*	12732	72375	12691	87204	12522
42292	12005	57071	14219	70483	14019	71822*	12734	72376*	12726	87205	12523
42293	12011	57103	14225	70484	Disc.	71823	12736	72377*	12728	87206	12524
42294	12012	57105	14226	70485	14013	71824	12753	72380	12742	87496	12428
42298	12013	57601	12236	70488	14000	71826	12759	72381	12744	87727	12426
42300	12008	57602	12235	70489	14005	71827	12738	72382	12746	87728	12425
42301	12021	57710	12226	70490	14004	71830	12755	72383	12748	87729	12436
42302	12009	58400	12225	70491	14003	71833	12739	72385	12936	87730	12422
42303	12010	58402	12224	70500	12113	71834	12761	72386	12935	87791	12605
42330	11104	58601	14314	70501	14020	71835	12752	72390	12932	87805	12415
42335	11105	58602	14312	70503	14002	71840*	12702	72391	12933	87806	12413
42340	11106	58603	14313	70504	14006	71841*	12704	72395	12784	87807	Disc.
42397	11097	58612	14317	70505	14010	71842*	12706	72396	12785	87808	12419
43096	11096	58613	14318	70506	14001	71843*	12708	72397	12781	87809	Disc.
43097	11094	58617	14310	70507	N/A	71844*	12712	72398	12780	87810	12421
43400	11087	58618	14311	70508	14021	71845*	12714	72400	12772	87811	12416
43401	11085	58619	14319	70509	14023	71847*	12722	72401	12771	87812	12414
44556	11117	58620	14320	70511	14007	71855	12700	72402	12773	87820	12591
44557	11115	60001	14070	70518	14008	71856	12710	72403	12774	87821	12592
44559	11120	60013	14027	70519	14011	71876	12733	72404	12775	87822	12593
44560	11118	60014	14028	70520	14012	71877	12735	72405	12776	87823	12594
44564	11119	60015	14029	70521	14009	71878	12737	72406	12777	87824	12595
45400	11090	60016	14030	70525	14043	71879	12754	72407	12778	87825	12596
45401	11088	60017	14031	70529	14085	71883	12756	72408	12779	87831	12568
45405	11089	60018	Disc.	70533	14065	71890	12763	72485	12959	87832	12569
45464	11093	60025	12800	70537	14074	71891	12764	72486	12961	87832	12599
45465	11091	60026	12793	70541	14067	71894*	12726	72487	12962	87833	12570
45466	11092	60027	12794	70550	14093	71895*	12728	72488	12963	87833	12600
45902	11109	60028	12795	70551	14094	71896	12747	72489	12954	87833	12600
46002	11110	60030	12797	70601	12112	71897	12745	72491	12952	87834	12571
46111	11125	60031	12798	70610	12111	71899	12749	72492	12953	87834	12601
47305	11102	60032	12799	70710	12201	71915	13013	72493	12957	87835	12572
48305	11101	60033	12801	70714	12202	71986	45838	72494	12955	87835	12602
48495	11107	60034	12804	70716*	12250	71987	45840	72495	12952	87836	12573
48504	11108	60035	12803	70717*	12252	72234	14052	72496	12957	87850	12575
48571	11100	60036	12802	70718	Disc.	72235	14053	73148	13212	87851	12576
52002	12231	60050	12787	70722	12205	72236	14054	75200	10999	87852	12577
52004	12230	60051	12788	70795	12207	72237	Disc.	85333	12849	87853	12578
52010	12233	60052	12789	70796	12208	72238	14056	85338	12851	87854	12579
53001	12232	60053	12790	70797	12209	72239	13209	86101	12264	87855	12580
54300	12108	60054	12791	70801	12213	72240	13201	86102	12237	87856	12558
54400	12109	60055	12792	70802	12214	72241	13203	86103	12239	87856	12581
54410	12106	60090	12300	70803	12216	72242	13209	86104	12240	87900	12554
54510	12107	60091	12301	70804	12212	72243	13210	86105	12265	87901	12553
54722	12104	60092	12302	70805	12215	72266	14072	86109	12266	87902	12554
55200	14402	60093	12303	70807	12211	72270	14097	86113	12260	87903	12555
55203	14403	60094	12304	70815	12248	72271	14060	86116	12261	87904	12556
55280	14324	60095	12305	71685	12921	72272	14063	86119	12242	87905	12557
55286	Disc.	60096	12306	71686	12922	72273	14083	86120	12241	87917	12559
55301	14308	60097	Disc.	71687	12923	72274	14088	86121	Disc.	87918	12560
55302*	14330	60098	12308	71688	12918	72275	14076	86122	12238	87919	12561
55304	14305	60099	12310	71689	12919	72276	14075	86124	12287	87920	12562
55307	14300	60100	12311	71690	12920	72277	14078	86125	12288	87932	12586
55308	14301	60101	12312	71691	12915	72278	14077	86126	12272	87933	12587
55310	14303	60120	16000	71692	12916	72279	14079	86127	12274	87934	12588
55311	14302	60121	16001	71693	12917	72282	14042	86128	12276	87935	12589
55315	14307	60122	16006	71694	12912	72283	14041	86129	12279	87936	12590
55320	14309	60124	16008	71695	12913	72284	14045	86130	12278	87940	12564
55660	Disc.	60125	16009	71696	12914	72285	14044	86131	12280	87942	12565
55663	14101	60126	16011	71736	12812	72286	14046	86134	12267	87944	12566
55664	Disc.	60127	16012	71737	12813	72287	14086	86135	12273	88031	12527
55666	14118	60170	12937	71738	12814	72288	14084	86136	12275	88033	12528
55671	14103	60171	12938	71739	12815	72290	14089	86137*	12277	88034	12529
55672	14109	60172	12939	71740	12816	72291	14087	86138	12281	88049	12530
55672	14112	60300	14026	71741	12817	72292	14062	86139	12244	88051	12531
55676	14119	60325	12283	71742	12818	72293	14061	86140	12243	88070	12500
55686	14105	60326	12284	71749	12805	72294	14064	86141	16100	88071	12501
55692	Disc.	60330	12285	71750	12806	72295	12765	86142	16101	88072	12502
55816	14466	60331	12286	71751	12807	72296	12766	86144	16103	88073	12503
55905	14416	60332	Disc.	71752	12808	72297	12769	86145	12270	88075	12504
55854	14461	70201	12222	71753	12809	72298	12770	86146	12271	88078	12532



FORNEY/R&B/SHARK CROSSOVER

Forney	Shark	R&B	Shark	R&B	Shark	R&B	Shark	R&B	Shark	R&B	Shark
88079	12533	7235	11093	07587*	12313	8121	12516	8502	12701	8723	12795
88080	12534	7239	11097	07588*	12314	8122	12517	8504	12702	8724	12793
93097	12050	7240	11098	07589*	12315	8123	12518	8506	12703	8725	12799
		7241	11099	07590*	12316	8124	12519	8508	12704	8726	12796
		7242	11100	7600	12224	8125	12520	8510	12705	8727	12794
		7260	12040	7601	12235	8126	12521	8512	12706	8728	12801
		7261	12041	7602	12225	8127	12522	8514	12707	8729	12803
		7262	12039	7603	12236	8128	12523	8516	12708	8730	12802
		7265	12000	7610	12250	8129	12524	8518	12709	8731	12804
		7266	12001	7612	12252	8130	12525	8520	12710	8732	16008
		7267	12002	7616	12248	8131	12526	8522	12711	8733	16009
		7268	12003	7701	12937	8140	12527	8524	12712	8734	16011
		7269	12004	7702	12938	8141	12528	8526	12713	8735	16012
		7270	12005	7703	12939	8142	12529	8528	12714	8740	12954
		7271	12006	7710	12851	8143	12530	8530	12715	8742	12952
		7272	12007	7730	12964	8144	12531	8532	12716	8743	12953
		7276	12008	7731	12965	8150	12532	8534	12717	8744	12951
		7277	12009	7732	12966	8151	12533	8540	12718	8745	12955
		7278	12010	7733	12967	8152	12534	8542	12719	8746	12956
		7281	12011	7734	12968	8153	12535	8546	12722	8747	12960
		7282	12012	7736	12969	8160	12536	8548	12723	8750	12659
		7286	12013	7737	12873	8161	12537	18550	12724	8751	12961
		7287	12014	7738	12874	8162	12538	8551	12725	8752	12962
		7296	12034	7739	12875	8163	12539	8556	12726	8753	12963
		7296	12035	7740	12876	8164	12540	8557	12727	8760	12936
		7298	12031	7741	12877	8165	12541	8559	12728	8762	12935
		7299	12030	7742	12878	8166	12542	8560	12729	8765	12805
		7300	12022	7787	12253	8167	12543	8570	12694	8766	12806
		7301	12023	8000	12401	8168	12544	8571	12695	8767	12807
		7302	12025	8001	12403	8168	12545	8574	12696	8768	12808
		7306	12026	8002	12405	8170	12546	8575	12697	8769	12809
		7307	12027	8004	12406	8171	12547	8578	12698	8770	12810
		7308	12028	8008	14480	8172	12548	8579	12699	8771	12811
		7309	12029	8010	12237	8173	12549	08595*	12731	8773	12812
		7310	12036	8011	12238	8174	12550	08598*	12732	8774	12813
		7317	12038	8012	12239	8175	12551	8599	12733	8775	12814
		7330	12018	8013	12240	8180	12552	08605*	12734	8776	12815
		7331	12019	8014	12245	8181	12553	8606	12735	8777	12816
		7350	11103	8020	12241	8182	12554	8607	12736	8778	12817
		7351	11101	8021	12242	8183	12555	8608	12737	8779	12818
		7352	11102	8023	12243	8184	12556	8609	12738	8781	12819
		7353	11104	8025	12244	8185	12557	08610*	12739	8782	12820
		7354	1110	8030	16100	8186	12558	8611	12740	8783	12821
		7355	11106	8031	16101	8192	12564	08612*	12741	8784	12822
		07356*	11107	8032	16102	8193	12565	8625	12742	8785	12823
		07357*	11108	8033	16103	8194	12566	08626*	12743	8786	12824
		07358*	11109	8040	12260	8195	12567	8628	12744	8787	12825
		07359*	11110	8041	12261	8196	12568	08629*	12745	08790*	12826
		7500	12100	8042	12264	8197	12569	8640	12750	08791*	12827
		7501	12100	8043	12265	8198	12570	8641	12751	08792*	12828
		7502	12102	8044	12266	8199	12571	8642	12752	08793*	12829
		7503	12103	8045	12262	8200	12572	8643	12753	08794*	12830
		7508	12104	8046	12267	8201	12573	8644	12754	08795*	12831
		7509	12105	8047	12270	8202	12574	8649	12755	08796*	12832
		7510	12106	8048	12271	8206	12575	8650	12756	08798*	12833
		7511	12107	8049	12263	8261	12576	8656	12746	08799*	12834
		7512	12108	8050	12287	8262	12577	8656	12759	08800*	12835
		7513	12109	8051	12288	8263	12578	8657	12747	08801*	12836
		7516	12111	8055	12272	8264	12579	8657	12760	08802*	12837
		7517	12112	8056	12273	8265	12580	8658	12749	08802*	12838
		7518	12113	8060	12274	8266	12581	8658	12762	08804*	12839
		7524	12234	8061	12275	8267	12582	8659	12748	8813	13013
		7525	12201	8065	12276	8268	12583	8659	12761	8816	13008
		7527	12202	8066	12277	8269	12584	8670	12763	8817	13007
		7528	12203	8070	12278	8270	12585	8671	12764	8819	13006
		7530	12205	8071	12279	8271	12586	8675	12765	8825	12912
		7531	12206	8072	12280	8271	12587	8676	12766	8826	12913
		7532	12207	8073	12281	8272	12587	8677	12767	8827	12914
		7533	12208	8075	12282	8272	12588	8678	12768	8828	12915
		7534	12209	8076	12289	8273	12588	8679	12769	8829	12916
		7535	12210	8077	12283	8273	12589	8680	12770	8830	12917
		7542	12211	8078	12284	8274	12589	8690	12771	8832	12918
		07543/4	12212	8079	12290	8274	12592	8691	12772	8833	12919
		7545	12213	8080	12422	8275	12563	8692	12773	8834	12920
		7550	12214	8087	12427	8275	12590	8694	12774	8836	12921
		7551	12050	8088	12428	8276	12591	8695	12775	8837	12922
		07552/3	12215	8089	12429	8277	12592	8696	12776	8838	12923
		7553	12216	8091	12420	8278	12593	8698	12777	8850	12924
		7580	12217	8091	12430	8279	12594	8699	12778	8851	12925
		7581	12218	8092	12433	8280	12595	8700	12779	8852	12926
		7582	12219	8092	12425	8281	12596	8702	12780	8853	12927
		7583	12220	8100	12500	8282	12597	8703	12781	8871	13201
		7584	12221	8101	12501	8283	12598	8706	12782	8872	13202
		7570	12222	8102	12502	8284	12599	8708	12783	8873	13204
		7571	12223	8103	12503	8285	12600	8708	12782	8875	13205
		07575*	12300	8104	12504	8286	12601	8710	12787	8878	13206
		07576*	12301	8110	12505	8287	12602	8711	12788	8883	13210
		07577*	12302	8111	12506	8288	12603	8712	12789	8884	13209
		07578*	12303	8112	12507	8291	12605	8713	12790	8885	13211
		07579*	12304	8113	12508	8310	12420	8714	12791	9000	14000
		07580*	12305	8114	12509	8312	12416	8715	12792	9001	14001
		07581*	12306	8115	12510	8315	12421	8716	16000	9002	14002
		07582*	12307	8116	12511	8316	12417	8717	16001	9003	14005
		07583*	12308	8117	12512	8317	12415	8718	16006	9004	14003
		07584*	12310	8118	12513	8318	12413	8720	12800	9006	14004
		07585*	12311	8119	12514	8319	12412	8721	12798	9010	14006
		07586*	12312	8120	12515	8500	12700	8722	12797	9011	14010

R&B/US FORGE/SHARK CROSSOVER

R&B	Shark	R&B	Shark	US FORGE	Shark	US FORGE	Shark	US FORGE	Shark	US FORGE	Shark
9017	14009	9547	14212	00210	12107	00754	A12G	01423	11040	08951	12265
9018	14012	09547B	14239	00301	12112	00755	A23P	01424	11041	08952	12266
9020	14022	9548	14213	00302	14006	00756	A24G	01433	11045	08954	12270
9021	14021	09548B	14240	00303	14007	00757	A25G	01434	11046	08955	12271
9022	14023	9549	14214	00400	14403	00758	A38G	01443	11050	10872	12014
9025	14018	09549B	14241	00401	14404	00759	W218P	01444	11051	50222	11115
9025	14024	9550	14215	00502	10999	00760	W220G	01602	12254	50223	11116
9026	14013	09550B	14242	00504	12938	00761	A15G	01823	11055	50632	11118
9027	14019	9551	14216	00505	12939	00762	12764	01824	11056	50633	11119
9028	14020	09551B	14244	00506	12237	00765	12724	01833	11060	50832	11118
9030	14025	9552	14217	00507	12238	00766	12726	01834	11061	50833	11119
9031	14026	09552B	14243	00509	12239	00768	12710	01843	11065	50932	11118
9040	14073	9553	14218	00511	12980	00769	12711	01844	11066	50933	11119
9041	14071	09553B	14245	00518	12208	00771	12700(10)	01932	11097	88100	14107
9043	14070	9554	14219	00547	12256	00775	12702	01933	11098	88122	14272
9044	14072	09554B	14246	00548	12213	00777	12706	02350	12040	88126	14278
9052	14027	9555	14221	00549	12216	00778	12707	02352	12253	91132	14078
9053	14028	9558	14225	00551	12214	00779	12708(5)	03001	12028	91133	14077
9054	14029	9559	14226	00600	12236	00780	12709	03002	12027	91134	14045
9055	14030	9570	14306	00601	12235	00781	12712	03003	12026	91137	14078
9056	14031	9571	14308	00602	12225	00782	12713	03023	12024	99075	14275
9057	14032	9572	14305	00603	12224	00783	12704(10)	03031	12031	99077	14219
9058	14036	9575	14301	00604	12304	00785	12714	03032	12035	99078	14219
9059	14034	9576	14300	00606	12313(2)	00786	12715	03033	12034	99081	14201
9060	14035	9577	14302	00610	12311	00789	13067(10)	03034	12033	99126	14120
9080	14060	9578	14307	00611	16101	00792	45838	03040	12016	99128	14312
9081	14063	9579	14309	00613	16100	00793	45840	03041	12017	99129	14313
9082	14062	9580	14330	00614	16102	00794	F436Z	03042	12020	99200	12805
9083	14061	9585	14317	00615	12222	00795	F460Z	03051	12037	99201	12806
9084	14064	9586	14312	00616	12202	00796	F480Z	03052	12038	99202	12807
9085	14066	9587	14318	00617	12219	00797	13069(5)	03054	12015	99203	12808
9090	14083	9588	14313	00618	12221	00799	12728(1)	06633	11015	99205	12809
9091	14088	9589	14314	00619	12217	00800	12243	07331	11099	99206	12810
9092	14086	9595	14327	00620	12218	00801	12242	08015	12443	99207	12811
9093	14084	9599	14328	00621	12226	00802	12241	08016	12444	99210	12812
9094	14087	9604	14323	00634	12231	00812	12201	08026	12459	99211	12813(3)
9095	14089	9605	14324	00637	12230	00885	13130	08027	12460	99212	12814(3)
9100	14052	9607	14322	00652	12000	00886	13131	08028	12491	99213	12815
9101	14053	9616	14401	00657	12051	00887	13122	08029	12490	99215	12816
9102	14054	9617	14402	00662	12002	00888	13120	08030	12426	99216	12817
9103	14055	9618	14404	00667	12004	00889	13121	08032	12425	99217	12818
9104	14056	9619	14403	00669	12043	00890	13123	08036	12422	99220	12819(3)
9105	14057	9655	14425	00672	12005	00891	13110	08044	12525	99221	12820(3)
9106	14058	9657	14423	00676	12013	00892	13111	08100	12552	99222	12821(3)
9107	14059	9658	14424	00677	12007	00893	13113	08101	12553	99223	12822(3)
9110	14090	9674	14432	00678	12011	00894	13105	08102	12554	99225	12823(3)
9111	14091	9714	14417	00679	12012	00895	13106	08103	12555	99226	12824
9112	14092	9715	14418	00680	12300	00896	13108	08104	12556	99227	12825
9115	14093	9726	14453	00681	12301 (2)	00910	12856	08105	12557	99230	12826
9116	14094	9730	14458	00682	12302	01103	14066	08106	12558	99231	12827
9120	14075	9730	14459	00683	12303	01104	14084	08322	12518	99232	12828
9121	14078	9730	14460	00685	12308	01107	14128	08323	12519	99233	12829
9122	14076	9755	14452	00686	12305	01108	14067	08324	12520	99235	12830
9123	14077	9757	14454	00687	12306	01114	14079	08325	12596	99236	12831
9124	14079	9843	14414	00688	12308	01115	14061	08326	12522	99237	12832
9125	14081	9853	14415	00689	12310	01116	14086	08330	12584	99240	31
9126	14080	9897	14503	00690	12311	01117	14087	08331	12585	99244	13212
9127	14082	9898	14504	00691	12312	01123	11010	08332	12586	99245	13201
9130	14042	9680	14462	00700	12772	01124	11011	08333	12587	99247	13204
9131	14041	US FORGE	Shark	00701	12771	01130	14076	08334	12588	99248	13205
9132	14045	00031	11120	00702	12773	01131	14082	08335	12589	99249	13206
9133	14044	00033	11119	00704	12734	01133	11015	08336	12590	99254	12924
9134	14046	00064	12021	00705	12731	01134	11016	08350	12575	99255	12925
9135	14047	00074	12010	00706	12736	01135	14057	08351	12576	99257	12927
9136	14048	00077	N/A	00707	12738	01136	14042	08352	12577	99304	12111
9139	14049	00088	14208	00708	12754	01138	14041	08353	12578	99401	14415
9145	14074	00089	14217	00709	12755	01143	11020	08354	12579	99402	14401
9146	14043	00090	14200	00710	12753	01144	11021	08355	12580	99408	14402
9147	14085	00091	14202	00711	12755	01145	14075	08356	12581	99903	14225
9149	14067	00092	14204	00712	12765	01146	14080	08608	12505	99904	14226
9504	14116	00093	14205	00713	12766	01148	14081	08609	12506	99905	14224
9509	14439	00094	14220	00717	12769	01149	14046	08610	12507		
9512	14103	00095	14212	00718	12770	01150	14073	08611	12509		
9513	14109	00096	14214	00719	12732	01151	14071	08613	12510		
9514	14105	00097	14215	00722	12742	01153	14031	08614	12511		
9530	14200	00102	14203	00723	SDP702SC	01160	14093	08619	12512		
9530B	14227	00103	14206	00725	12744	01161	14094	08620	12513		
9531	14201	00104	14213	00726	12963	01162	14070	08621	12514		
9531B	14228	00105	14217	00728	12961	01163	14072	08622	12515		
9532	14202	00106	14339	00729	12959	01165	14095	08623	12516		
9532B	14229	00108	14302	00730	12960	01166	14097	08624	12517		
9533	14203	00109	14308	00731	12954	1168	14027	08625	12518		
9533B	14230	00110	14101	00732	12953	01173	14020	08626	12519		
9534	14204	00113	14300	00734	12952	1173	14020	08627	12595		
9534B	14231	00118	14327	00735	12955	01174	14002	08701	12542		
9535	14205	00119	14309	00736	12957	01175	14010	08702	12543		
9535B	14232	00125	14119	00738	12750	01176	14001	08910	12446		
9537	14206	00126	14118	00740	12787	1177	14021	08915	12447		
9538	14208	00127	14117	00741	12788	01180	14000	08916	12277		
9538B	14233	00140	14467	00742	12789	01184	14017	08920	12247		
9539	14433	00172	12050	00743	12790	01185	14018	08922	12283		
9540	14209	00200	12100 (1)	00744	12791	01323	11025	08923	12284		
9540B	14236	00201	12106	00745	12792	01324	11026	08924	12285		
9541	14210	00203	12100	00748	12752	01333	11030	08925	12286		
9541B	14237	00206	12250	00751	A4G	01334	11031	08927	12274		
9546	14211	00207	12252	00752	A5P	01343	11035	08928	12275		
9546B	14238	00208	12102	00753	A11	01344	11036	08950	12263		



INDEX

Item	Page	Item	Page	Item	Page	Item	Page	Item	Page	Item	Page
19	4	11017	107	11115	111	12224	124	12419	125	12565	155
20	4	11018	107	11116	111	12225	124	12421	125	12566	155
21	4	11019	107	11117	111	12226	118	12422	128	12567	155
22	4	11020	107	11118	111	12227	118	12423	128	12568	155
23	4	11021	107	11119	111	12230	118	12424	128	12569	155
25	48	11022	107	11120	111	12231	118	12425	128	12570	149/155
26	48	11023	107	11121	111	12232	118	12426	128	12571	155
41	5	11024	107	11122	110	12233	118	12427	128	12572	149/155
43	5	11025	107	11123	110	12234	118	12428	128	12573	155
48	5	11026	107	11124	110	12235	124	12429	128	12574	149/156
49	5	11027	107	11125	110	12236	124	12430	128	12575	156
50	5	11028	107	11127	110	12237	121/149/150	12431	8/22	12576	156
51	184	11029	107	11128	111	12238	121	12433	8/22	12577	149/150/156
52	184	11030	107	11132	108	12239	121	12440	128	12578	156
53	184	11031	107	12000	112	12240	121	12441	128	12579	156
54	184	11032	107	12001	112	12241	121	12442	129	12580	156
56	15	11033	107	12002	112	12242	121/149	12443	129/150	12581	156
57	15	11034	107	12003	112	12243	121	12444	129/150	12582	156
60	183	11035	107	12004	112	12244	121	12445	129	12583	156
61	183	11036	107	12005	112	12245	123	12446	129	12584	156
65	183	11037	107	12006	112	12246	124	12447	129	12585	156
66	183	11038	107	12007	112	12247	125	12448	129	12586	156
76	184	11039	108	12008	112	12248	117	12449	129	12587	156
114	78	11040	108	12009	112	12250	123	12454	129	12588	156
323	20	11041	108	12010	112	12251	123	12455	129	12589	156
333	20	11042	108	12011	112	12252	123	12459	129/149	12590	156
343	20	11043	108	12012	112	12253	117	12460	129/149	12591	156
2004	82	11044	108	12013	112	12254	117	12462	126	12592	156
2006	82	11045	108	12014	112	12255	145	12463	126	12593	156
2007	82	11046	108	12015	113	12256	124	12464	125	12594	156
2008	82	11047	108	12016	113	12257	124	12465	125	12595	156
2009	82	11048	108	12017	113	12258	124	12470	150	12596	156
2010	82	11049	108	12018	113	12260	127	12471	150	12597	156
2011	82	11050	108	12019	113	12261	126	12490	149/150	12598	156
2012	82	11051	108	12020	113	12263	126/150	12491	149/150	12599	149/150/156
2013	82	11052	108	12021	112	12264	126	12500	153	12600	156
2014	82	11053	108	12024	113	12265	126	12501	153	12601	150/156
2015	82	11054	108	12025	113	12266	126	12502	153	12602	156
2017	82	11055	108	12026	113	12268	126	12503	153	12603	150/156
2020	82	11056	108	12027	113	12270	126/149/150	12504	153	12604	150/156
2021	82	11057	108	12028	113	12271	126	12505	153	12605	156
2023	82	11058	108	12029	113	12272	127	12506	153	12606	154
2024	82	11059	108	12031	113	12273	127	12507	153	12607	154
2025	82	11060	108	12032	113	12274	127	12508	153	12608	154
2027	82	11061	108	12033	113	12275	127	12509	153	12609	154
2029	82	11062	108	12034	113	12276	128	12510	153	12610	154
2030	82	11063	108	12035	113	12277	128	12511	153	12611	154
2031	82	11064	108	12036	114	12278	127	12512	153	12612	36
2033	82	11065	108	12037	114	12279	127	12513	153	12613	36
2035	82	11066	108	12038	114	12280	128	12514	153	12614	36
2036	82	11067	108	12040	114	12281	128	12515	153	12615	36
2037	82	11068	108	12041	114	12283	127	12516	153	12616	36
2038	82	11069	108	12042	112	12284	127	12517	153	12617	36
2039	82	11070	108	12043	112	12285	128	12518	153	12618	36
4046	16	11071	108	12050	111	12286	128	12519	153	12619	36
6200	32	11072	108	12051	112	12287	127	12520	153	12621	36
6202	35	11073	108	12052	112	12288	127	12521	153	12622	36
6205	35	11074	108	12061	112	12289	127	12525	153	12623	36
6206	35	11075	108	12062	112	12290	127	12527	154	12624	36
6300	32	11076	108	12063	112	12291	128	12528	154	12625	36
6302	35	11077	108	12064	112	12292	128	12529	154	12626	36
6305	35	11078	108	12100	119	12293	128	12530	154	12627	36
6306	35	11079	108	12101	119	12294	128	12531	154	12628	36
6400	32	11080	108	12102	119	12295	117	12532	154	12629	36
7000	71	11081	108	12103	119	12296	117	12533	154	12630	36
7046	16	11082	108	12104	118	12298	118	12534	154	12631	36
7080	16	11083	108	12105	119	12300	125	12535	154	12632	36
00036	43	11085	109	12106	119	12301	125	12536	154	12633	36
00040	43	11086	109	12107	119	12302	125	12537	154	12634	36
00060	43	11087	109	12108	119	12303	125	12538	154	12635	46
00080	43	11088	109	12109	119	12304	125	12539	154	12636	46
00100	43	11089	109	12110	120	12305	125	12540	154	12637	46
00120	43	11090	109	12111	120	12306	125	12541	154	12638	46
00150	43	11091	109	12112	120	12308	125	12542	155	12639	13
00180	43	11092	109	12113	119	12309	125	12543	155	12640	13
00220	43	11093	109	12201	123	12310	125	12544	155	12641	13
10059	184	11094	109	12202	123	12311	125	12545	155	12642	13
10060	184	11095	109	12205	123	12312	125	12546	155	12643	13
10999	124	11096	109	12206	123	12313	125	12547	155	12644	13
11000	107	11097	110	12207	121	12314	125	12548	155	12645	13
11001	107	11098	110	12208	121	12315	125	12549	155	12646	13
11002	107	11099	110	12209	121	12394	145	12550	155	12647	13
11003	107	11100	111	12210	121	12395	145	12551	155	12648	13
11004	107	11101	110	12211	120	12396	145	12552	155	12649	13
11005	107	11102	110	12212	120	12398	145	12553	155	12663	8
11006	107	11103	111	12213	120	12399	145	12554	155	12670	150
11007	107	11104	111	12214	120	12401	150	12555	150/155	12671	150
11008	107	11105	111	12215	120	12402	149	12556	155	12672	150
11009	107	11106	111	12216	120	12403	149	12557	155	12673	122
11010	107	11107	110	12217	122	12411	150	12558	155	12674	122
11011	107	11108	110	12218	122	12412	125	12559	155	12675	122
11012	107	11109	110	12219	122	12413	125	12560	155	12676	122
11013	107	11110	110	12220	122	12414	125	12561	155	12677	122
11014	107	11112	111	12221	122	12415	125	12562	155	12678	122
11015	107	11113	111	12222	122	12416	125	12563	155	12679	122
11016	107	11114	111	12223	122	12418	125	12564	155	12689	13

INDEX

Item	Page	Item	Page	Item	Page	Item	Page	Item	Page	Item	Page
12690	15	12788	78	12923	70	13031	6	13160	50	13271	187
12691	15	12789	78	12924	44	13032	6	13161	50	13272	187
12692	15	12790	78	12925	44	13033	6	13162	50	13273	187
12693	8/22	12791	78	12926	44	13034	7	13163	50	13274	187
12694	7	12792	78	12927	44	13035	7	13164	50	13275	187
12695	7	12805	39	12928	44	13036	7	13165	50	13276	187
12696	8	12806	39	12929	44	13037	7	13166	50	13277	187
12697	8	12807	39	12930	44	13038	7	13167	50	13278	187
12698	8	12808	39	12931	44	13039	7	13168	50	13279	187
12699	8	12809	39	12932	81	13040	7	13169	50	13280	187
12700	4	12810	39	12933	81	13041	7	13170	50	13281	187
12701	4	12811	39	12934	81	13042	7	13171	50	13282	187
12702	4	12812	39	12935	8/22	13043	7	13172	50	13284	186
12703	4	12813	39	12936	78	13049	13	13173	50	13285	186
12704	4	12814	39	12937	158	13050	13	13174	50	13286	186
12705	4	12815	39	12938	158	13051	13	13175	50	13287	186
12706	4	12816	39	12939	158	13052	13	13176	50	13288	186
12707	4	12817	39	12940	158	13053	13	13177	50	13289	186
12708	4	12818	39	12941	158	13054	13	13178	4	13962	174
12709	4	12819	39	12942	158	13055	5	13179	4	13963	174
12710	5	12820	39	12943	158	13057	5	13180	7	13964	174
12711	5	12821	39	12944	158	13058	8	13181	7	13965	174
12712	5	12822	40	12950	166	13059	8	13182	51	13966	174
12713	5	12823	40	12951	167	13060	8	13183	51	13967	174
12714	5	12824	40	12952	166/167	13061	8	13184	51	13968	174
12715	5	12825	40	12953	166/167	13062	28	13185	51	13969	174
12716	5	12826	40	12954	166/167	13063	7/14	13186	51	13970	174
12717	5	12827	40	12955	166/167	13064	14	13187	51	13971	174
12718	5	12828	40	12956	167	13068	5	13188	51	13972	174
12719	5	12829	40	12957	166/167	13069	7	13189	51	13973	174
12722	5	12830	40	12958	60	13070	7	13201	21	13974	174
12723	5	12831	40	12959	167	13072	14	13202	21	13975	174
12724	7	12832	40	12960	167	13073	34	13203	21	13976	174
12725	7	12833	40	12961	167	13074	34	13204	21	13977	174
12726	8	12834	40	12962	167	13075	34	13205	21	13979	175
12727	8	12835	40	12963	167	13076	188	13206	21	13980	177
12728	8	12836	40	12964	158	13077	188	13207	21	13981	177
12729	8	12837	40	12965	158	13078	188	13209	21	13982	177
12730	6	12838	40	12966	158	13099	70	13210	21	13983	177
12731	12	12839	40	12967	158	13100	70	13211	21	13984	177
12732	12	12840	37	12968	158	13101	70	13212	21	13985	177
12733	12	12841	37	12969	158	13102	70	13213	22	13986	177
12734	12	12842	37	12976	158	13103	70/71	13215	4	13987	177
12735	12	12843	37	12977	158	13104	70/71	13216	4	13988	175
12736	12	12844	37	12978	158	13105	70	13217	6	13989	176
12737	12	12845	37	12979	158	13106	70	13218	6	13990	176
12738	12	12846	37	12980	158	13107	70	13219	28	13991	176
12739	13	12847	37	12981	158	13108	70	13220	28	13992	171
12740	13	12848	157	12982	158	13109	70	13221	28	13993	171
12741	12	12849	157	12983	158	13110	70	13222	28	13995	175
12742	13	12850	157	12984	158	13111	70	13223	28	13996	175
12743	13	12851	157	12985	158	13112	70	13224	29	13997	173
12744	13	12854	157	12986	44	13113	70	13225	29	13998	173
12745	13	12855	157	12987	44	13114	70	13226	37	13999	172
12746	13	12856	157	12988	44	13115	70/71	13227	37	14000	171
12747	13	12857	157	12989	44	13116	70/71	13228	37	14001	171
12748	13	12858	157	12990	44	13117	70	13229	37	14002	171
12749	13	12859	157	12991	44	13118	70	13230	37	14003	171
12750	12	12866	157	12992	44	13119	70	13231	37	14004	171
12751	12	12867	157	12993	44	13120	70	13232	37	14005	171
12752	12	12868	157	12994	44	13121	70	13233	37	14006	172
12753	12	12870	157	12995	44	13122	70	13234	37	14007	172
12754	12	12871	157	12996	44	13123	70	13235	37	14008	172
12755	13	12872	157	12997	44	13124	70	13236	37	14009	172
12756	13	12873	158	12998	44	13125	70	13237	37	14010	172
12757	6	12874	158	12999	44	13126	70	13238	37	14011	172
12758	6	12875	158	13000	28	13127	70	13239	37	14012	172
12759	14	12876	158	13001	28	13128	70	13240	37	14013	171
12760	14	12877	158	13002	28	13129	70	13241	37	14014	171
12761	14	12878	158	13003	28	13130	70	13242	38	14017	173
12762	14	12879	157	13004	28	13131	70	13243	38	14018	173
12763	14	12880	157	13005	28	13132	70	13244	38	14019	173
12764	14	12882	184	13006	28	13133	70	13245	38	14020	173
12765	16	12900	58	13007	29	13134	59	13246	38	14021	173
12766	16	12901	58	13008	29	13135	59	13247	38	14022	173
12767	16	12902	58	13009	29	13136	59	13248	38	14023	173
12768	16	12903	58	13010	29	13137	59	13249	38	14024	175
12769	16	12904	58	13011	29	13138	59	13250	38	14025	173
12770	16	12905	58	13012	20	13139	59	13251	38	14026	173
12771	82	12906	60	13013	20	13140	60	13252	38	14027	174
12772	82	12907	60	13014	20	13141	60	13253	38	14028	174
12773	82	12908	60	13015	34	13142	46	13254	38	14029	174
12774	82	12909	60	13016	34	13143	46	13255	38	14030	174
12775	82	12910	60	13017	34	13144	46	13256	38	14031	174
12776	82	12911	60	13018	28	13145	46	13257	38	14032	174
12777	82	12912	70	13019	28	13146	46	13258	38	14033	176
12778	82	12913	70/71	13020	29	13147	46	13259	38	14034	175
12779	82	12914	70	13021	6	13148	60	13260	187	14035	175
12780	82	12915	70	13022	6	13152	5	13261	187	14040	172
12781	82	12916	70	13023	6	13153	5	13262	187	14041	176
12782	8/22/34	12917	70	13024	6	13154	5	13263	187	14042	176
12783	81	12918	70/71	13025	20	13155	5	13264	187	14043	176
12784	81	12919	70/71	13026	20	13156	12	13265	187	14044	176
12785	81	12920	70	13028	6	13157	12	13266	187	14045	176
12786	81	12921	70	13029	6	13158	8	13267	187	14046	176
12787	78	12922	70	13030	6	13159	8	13270	187	14047	176

120/173



INDEX

Item	Page	Item	Page	Item	Page	Item	Page	Item	Page	Item	Page
14048	176	14219	103	14441	139	16023	161	17022	87	45823	58
14049	176	14220	103	14442	139	16024	161	17023	89	45824	58
14050	176	14221	103	14443	145	16025	161	17024	90	45825	58
14051	176	14222	103	14444	118	16026	161	17025	90	45826	58
14052	176	14223	103	14448	139	16027	162	17026	85/86	45827	58
14053	176	14224	103	14450	144	16028	163	17030	92	45828	58
14054	176	14225	103	14451	144	16029	164	17031	92	45829	58
14056	176	14226	103	14452	144	16030	164	17032	92	45830	58
14057	176	14250	96	14453	144	16031	164	17033	92	45831	58
14058	176	14251	96	14454	144	16032	164	17034	92	45832	58
14059	176	14252	99	14455	144	16033	164	17035	92	45833	58
14060	177	14253	99	14456	144	16034	163	17036	92	45834	58
14061	177	14254	99	14457	144	16035	163	17037	92	45835	58
14062	177	14255	99	14458	144	16036	163	17038	92	45836	61
14063	177	14256	99	14459	144	16037	164	17039	92	45837	61
14064	177	14257	99	14460	144	16038	164	17040	92	45838	61
14065	177	14262	97/98	14461	144	16039	162/164	17041	92	45839	61
14066	177	14263	98	14463	138	16040	162/164	17042	93	45840	61
14067	177	14264	97/98	14466	144	16041	164	17043	93	45841	61
14068	177	14265	98	14467	144	16042	164	17044	93	45842	61
14069	173	14266	97/98	14468	144	16043	163	18060	183	45843	61
14070	175	14267	98	14469	144	16044	164	18061	183	45846	58
14071	175	14268	98	14480	95	16045	164	18062	183	45847	58
14072	175	14269	96/99	14481	94	16046	163	23536	45	45848	58
14073	175	14270	99	14482	95	16047	163	23540	45	45849	58
14074	175	14272	100	14483	94	16049	163	23580	45	45850	58
14075	176	14274	102	14500	143	16050	166	23636	45	45851	58
14076	176	14275	102	14501	143	16051	166	23640	45	45852	58
14077	176	14276	134	14502	143	16052	166	23680	45	45853	58
14078	176	14277	102	14503	143	16053	166	24036	46	45854	58
14079	176	14278	134	14504	143	16054	166	24040	46	45855	58
14080	176	14300	135	14505	143	16055	166	24060	46	45856	58
14081	176	14301	135	14506	143	16056	166	24080	46	45857	58
14082	176	14302	135/150	14507	143	16057	166	24120	46	45858	58
14083	177	14303	135	14508	143	16058	166	24180	46	45859	58
14084	177	14305	135/149/150	14509	143	16059	166	27036	46	45860	58
14085	177	14306	136	14510	143	16060	166	27040	46	45861	58
14086	177	14307	136	14511	143	16061	166	27060	46	45862	58
14087	177	14308	136	14519	142	16062	166	27080	46	45863	59
14088	177	14309	136	14520	142	16063	166	27120	46	45864	59
14089	177	14310	133	14521	142	16064	166	27150	46	45865	59
14090	178	14311	133	14522	142	16066	166	40100	39	45866	59
14091	178	14312	133	14523	142	16067	164	40120	39	45867	59
14092	178	14313	133	14524	142	16068	163	40160	39	45868	59
14093	178	14314	134	14525	140	16069	163	40240	39	45869	60
14094	178	14315	133	14601	34	16070	164	40360	39	45870	59
14095	174	14316	133	14602	34	16071	164	40500	39	45871	59
14096	174	14317	133	14603	34	16072	164	40800	39	45872	59
14097	174	14318	133	14604	34	16073	164	43220	35	45873	59
14098	172	14319	133	14605	34	16074	164	43221	35	45874	59
14099	172	14320	133	14606	34	16075	164	43222	35	45875	59
14101	101	14321	137	14607	34	16076	163	43223	35	45876	59
14103	101	14322	137	14866	145	16077	165	43224	35	45877	59
14105	101	14323	137	14868	145	16078	165	43225	35	45878	60
14106	100	14324	137	15000	43	16079	165	43226	35	45879	59
14107	100	14327	137	15001	43	16080	165	43227	35	45880	59
14109	101	14328	137	15002	43	16081	165	43228	35	45881	59
14112	101	14329	135	15003	43	16082	165	43229	35	45882	59
14114	101	14330	136	15004	43	16083	165	44320	20	45883	59
14116	101	14331	133	15005	43	16084	165	44321	20	45884	59
14117	134	14332	133	15006	43	16085	165	44322	20	45885	60
14118	134	14333	134	15007	43	16086	165	45085	45	45886	60
14119	134	14334	134	15008	43	16087	165	45086	45	45887	60
14120	134	14338	136	15009	43	16088	165	45087	45	45888	60
14128	177	14339	137	15010	43	16089	165	45088	45	45889	60
14129	178	14340	102	15011	43	16100	126	45089	45	45890	60
14130	177	14341	102	15012	43	16101	126	45090	45	45891	60
14134	177	14342	137	15013	43	16102	126	45091	45	45892	60
14135	102	14343	137	15014	43	16103	126	45092	45	45893	60
14136	178	14344	137	15015	43	16201	35	45093	45	45894	60
14137	97/102	14399	141	15016	43	16202	35/48	45094	45	45895	60
14138	177	14400	141	15017	43	16203	35/48	45095	45	45896	60
14139	177	14401	140	15018	43	16204	35	45096	45	45897	60
14140	176	14402	140	16000	162/164	16205	35	45097	45	45898	60
14141	172	14403	140	16001	164	16206	35	45098	45	45899	60
14142	97/134	14404	141	16002	164	16207	35	45099	45	45900	60
14155	178	14414	141	16003	164	16208	34/35	45100	39	45901	60
14200	103	14415	141	16004	162/164	16209	34/35	45120	39	45902	60
14201	103	14416	138	16005	162/164	16210	35	45160	39	45903	61
14202	103	14417	138	16006	164	16211	35	45240	39	45904	61
14203	103	14418	138	16007	162/164	16401	32	45360	39	45905	61
14204	103	14419	138	16008	163	16402	32	45500	39	45906	61
14205	103	14421	138	16009	163	16403	48	45736	59	45907	61
14206	103	14422	138	16010	162/163	17001	179	45737	59	45908	61
14207	103	14423	138	16011	162/163	17002	179	45738	59	45909	61
14208	103	14424	138	16012	162/163	17003	179	45739	59	45910	61
14209	103	14425	138	16013	163	17004	179	45740	59	45912	61
14210	103	14426	139	16014	162	17005	172	45741	59	45913	61
14211	103	14427	139	16015	162	17007	179	45742	59	45914	61
14212	103	14428	139	16016	161	17010	85	45743	59	45915	61
14213	98/103	14432	139	16017	161	17011	86	45744	59	45916	61
14214	103	14433	139	16018	161	17012	87	45800	39	45917	61
14215	103	14435	139	16019	161	17016	91	45819	58	45918	61
14216	103	14438	139	16020	161	17018	88	45820	58	45919	61
14217	103	14439	139	16021	161	17020	85	45821	58	45920	61
14218	103	14440	139	16022	162/163	17021	86	45822	58	45921	61

INDEX

Item	Page	Item	Page	Item	Page	Item	Page	Item	Page	Item	Page
45922	61	46018	63	46118	67	47018	56	17004R	179	40360Z-3	41
45923	61	46019	63	46119	67	47019	56	2012G	82	4046-10	16
45924	61	46020	63	46120	67	50100	40	2016G	82	40500Z	41
45925	61	46021	63	46121	67	50120	40	2022-10	82	40500Z-3	41
45926	61	46022	63	46122	67	50160	39	2032-24	82	4060-10	16
45927	61	46023	62	46123	67	50240	39	2035-24	82	40800Z	41
45928	61	46024	64	46124	67	50360	39	2035-46	82	40800Z-3	41
45929	61	46025	64	46125	67	50500	40	235100V	45	41-100	5
45930	61	46026	64	46126	67	50800	40	235120V	45	42-100	5
45931	61	46027	64	46127	67	64000	185	235150V	45	43-100	5
45932	61	46028	64	46128	67	64001	185	235180V	45	44-100	5
45933	61	46029	64	46129	67	64002	185	235220V	45	45-100	5
45934	62	46030	64	46130	67	64003	185	235240V	45	45240C	39
45935	62	46031	64	46131	67	64004	185	235320V	45	45240Z	41
45936	62	46032	64	46132	67	64005	185	23536V	45	45240Z-3	41
45937	62	46033	64	46133	67	64006	185	235400V	45	45240ZC	41
45938	62	46034	64	46134	67	64007	185	23540V	45	4536-10	16
45939	62	46035	64	46135	67	64008	185	23580V	45	4536-3	16
45940	62	46036	64	46136	67	70100	40	236100V	45	45360Z	41
45941	62	46037	64	46137	67	70120	40	236120V	45	45360Z-3	41
45942	62	46038	64	46138	67	70160	40	236150V	45	4546-10	16
45943	62	46039	64	46139	67	70240	40	236180V	45	4546-3	16
45944	62	46040	64	46140	67	70360	40	236220V	45	45500Z	41
45945	62	46041	64	46141	67	70500	40	236240V	45	45500Z-3	41
45946	62	46042	64	46142	67	70600	40	236320V	45	4560-10	16
45947	62	46043	64	46143	68	70800	40	23636V	45	4560-3	16
45948	62	46044	64	46144	68	73750	69	236400V	45	45800Z	41
45949	62	46045	64	46145	68	73752	69	23640V	45	45800Z-3	41
45950	62	46046	64	46146	68	73753	69	23680V	45	46-100	5
45951	62	46047	64	46147	68	73754	69	24-10	4	47-100	5
45952	62	46048	64	46148	68	73755	69	24-100	4	48-100	5
45953	62	46049	64	46149	68	73757	69	24-20	4	49-100	5
45954	62	46050	64	46150	68	73758	69	24-50	4	50-100	5
45955	62	46051	64	46151	68	73759	69	24036V	46	50240C	39/41
45956	62	46052	64	46152	68	73760	69	24040V	46	50240Z	41
45957	62	46053	64	46153	68	73762	69	24060V	46	50240Z-3	41
45958	62	46054	64	46154	68	73763	69	24080V	46	50360C	39
45959	62	46055	65	46155	68	73764	69	24120V	46	50360Z	41
45960	62	46056	65	46156	68	73765	69	25-20	4	50360Z-3	41
45961	62	46057	65	46157	68	73767	69	25-25	4	50360ZC	41
45962	62	46058	65	46158	68	73768	69	25-5	4	50500Z	41
45963	62	46059	65	46159	68	73769	69	25-6	4	50500Z-3	41
45964	62	46060	65	46160	68	73770	69	25SL-10	6	50800Z	41
45965	62	46061	65	46161	68	73780	69	25SL-M	6	50800Z-3	41
45966	62	46062	65	46162	68	80000	44	26-20	4	610T	30
45967	62	46063	65	46163	68	80001	44	26-25	4	610T-100	30
45968	62	46064	65	46164	68	80002	44	26-5	4	610TB	30
45969	62	46065	65	46165	68	82751	69	26-6	4	612T	28
45970	62	46066	65	46166	68	82752	69	26-6M	6	612T-100	30
45971	62	46067	65	46167	68	82753	69	26SL-10	6	612TB	28
45972	62	46068	65	46168	68	82754	69	26SL-M	6	614T	30
45973	62	46069	65	46169	68	83751	69	27-100	4	614T-100	30
45974	62	46070	65	46170	68	83752	69	27-25	4	614T-1000	30
45975	62	46071	65	46171	68	83753	69	29-10	4	614TB	28
45976	62	46072	65	46172	68	83754	69	29SL	6	616TB	28
45977	62	46073	65	46173	68	88000	44	30-10	4	620T	30
45978	62	46074	65	46174	68	88001	44	30-100	4	620T-1000	30
45979	62	46075	65	46175	68	88002	44	32120GT	37	620T-50	30
45980	62	46076	65	46180	57	90100	40	3220GT	48	620T-500	30
45981	63	46077	65	46181	57	90120	40	3220GT-100	37	620TB	48
45982	63	46078	65	46182	57	90160	40	3230GT-1	33	620TB-1	33
45983	63	46079	65	46183	57	90240	40	3230GT-100	37	620TB-1000	28
45984	63	46080	65	46184	57	90360	40	3230ZGT	48	620TB-500	28
45985	63	46084	66	46185	57	90500	40	323T	33/48	620TBA	32
45986	63	46085	66	46186	57	90800	40	323T-50	20	620TC	30
45987	63	46086	66	46187	57	235100	45	3250GT	48	621TB	28
45988	63	46087	66	46188	57	235120	45	3250GT-100	37	621TB-50	28
45989	63	46088	66	46189	57	235150	45	3280GT-1	33	621TBC	28
45990	63	46089	66	46190	57	235180	45	3280GT-100	37	622T	30
45991	63	46090	66	46191	57	235220	45	33120GT	37	622T-1000	30
45992	63	46091	66	46192	57	235240	45	3320GT-100	37	622T-50	30
45993	63	46092	66	46193	57	235320	45	3330GT	48	622T-500	30
45994	63	46093	66	46194	57	235400	45	3330GT-1	33	622TB	48
45995	63	46094	66	46195	57	236100	45	3330GT-100	37	622TB-1	33
45996	63	46095	66	46196	57	236120	45	3330ZGT	48	622TB-1000	28
45997	63	46096	66	46197	57	236150	45	333S	21	622TB-500	28
45998	63	46097	66	46198	57	236180	45	333SP	21	622TC	30
45999	63	46098	66	46199	57	236220	45	333T	33/48	623TB	28
46000	63	46099	66	47000	56	236240	45	333T-50	20	623TB-50	28
46001	63	46100	66	47001	56	236320	45	3350GT	48	623TBC	28
46002	63	46101	66	47002	56	236400	45	3350GT-100	37	624T	30
46003	63	46102	66	47003	56	121-5	8	3380GT-1	33	624T-1000	30
46004	63	46103	66	47004	56	122-5	8	3380GT-100	37	624T-50	30
46005	63	46104	66	47005	56	122M-5	8	343T-50	20	624T-500	30
46006	63	46105	66	47006	56	123-5	8	37-10	4	624TB	28/48
46007	63	46106	66	47007	56	124-5	8	37-100	4	624TB-1000	28
46008	63	46107	66	47008	56	124D	8	37L	8/22	624TB-500	28
46009	63	46108	66	47009	56	13109-1	33	37S	8/22	624TC	30
46010	63	46109	67	47010	56	13110-1	33	37SL	6	626T	31
46011	63	46110	67	47011	56	14049B	176	38-5	4	626T-1000	31
46012	63	46111	67	47012	56	141-5	8	38-50	4	626T-50	31
46013	63	46112	67	47013	56	142M-5	8	38SL	6	626T-500	31
46014	63	46113	67	47014	56	142MH-5	8	40240Z	41	626TB	28
46015	63	46114	67	47015	56	143-5	8	40240Z-3	41	626TB-1000	28
46016	63	46115	67	47016	56	17003N	179	4036-10	16	626TB-50	28
46017	63	46117	67	47017	56	17004N	179	40360Z	41	626TBC	28



INDEX

Item	Page	Item	Page	Item	Page	Item	Page
626TC	31	7060H-10	16	BT52	163	12249	124
630T	31	7080-10	16	BT53	164	13012	19
630T-1000	31	70800Z	41	BT54	163	13067	5
630T-50	31	70800Z-3	41	BT55	163	13082	5
630T-500	31	7080H-10	16	BT56	164	13084	19
630TB	48	708E	175	BT57	164	13085	19
630TB-1	33	709E	175	BT58	164	13090	3
630TB-1000	29	712E	174	BT59	164	13091	3
630TC	31	719E	175	BT5A	162	13092	3
631TB	29	720E	175	BT63	164	13290	72
631TB-50	29	760S	177	BT64	164	13291	72
631TBC	29	761T	177	BT68	163	13292	72
632T	31	767S	176	BT8	162	13293	72
632T-1000	31	777S	176	BT9	163	13294	72
632T-50	31	787S	177	BTA4	165	13295	72
632T-500	31	90240Z	42	BTE4	165	13296	72
632TB	48	90240Z-3	42	BTE6	165	13297	72
632TB-1	33	90360Z	42	BTM	161	13298	72
632TB-1000	29	90360Z-3	42	BTM-1	161	13299	72
632TB-500	29	90500Z	42	BTM-2	161	13300	72
632TC	31	90500Z-3	42	BTM-3	161	13301	72
633TB	29	90800Z	42	BTM-4	161	13302	72
633TB-50	29	90800Z-3	42	BTM-5	161	13312	72
633TBC	29	A1	76/77	BTM-6	161	13313	72
634T	31	A11	76/77	BTM-7	161	13314	72
634T-50	31	A12	76/77	BTM-8	161	13315	72
634T-500	31	A13	76/77	BTM-9	161	13316	72
634T-1000	31	A14	76/77	FT450	42	13961	175
634TB	29/48	A15	76/77	FTA	42	14475	95
634TB-1000	29	A15L	76/77	S1050A	186	14476	95
634TB-50	29	A2	76/77	S1060A	186	14477	94
634TBC	29	A21	76/77	S1150A	186	14479	95
634TC	31	A23	76/77	S1250A	186	16501	146
636T	31	A24	76/77	S3660	185	16502	146
636T-1000	31	A25	76/77	S3665	185	16503	146
636T-50	31	A25S	33/77	S3670	185	16504	146
636T-500	31	A26	76/77	S6600	33	16505	146
636TB	29	A3	76/77	S6650	33	16506	146
636TB-1000	29	A31	76/77	S4010A	186	16507	146
636TB-50	29	A32	76/77	S4020	186	16508	146
636TBC	29	A34	76/77	S4030A	186	16690	47
636TC	31	A36	76/77	SDP220	12	2019-10	82
640T	31	A37	76/77	SDP260	12	23681	47
640T-1000	31	A38	76/77	SDP280	12	23682	47
640T-50	31	A39	76/77	SDP301	12	23683	47
640T-500	31	A4	76/77	SDP401	12	23684	47
640TB	29	A5	76/77	SDP401-25	12	23685	47
640TB-50	29	AW5	78	SDP401-5	12	23686	47
640TBC	29	AW5S	78	SDP402	12	23687	47
640TC	31	AW7	78	SDP402-100	12	23688	47
642T	31	AW10	78	SDP402-25	12	23689	47
642T-1000	31	BT10	162/163	SDP402-3	12	23690	47
642T-50	31	BT11	164	SDP402-5	12	23691	47
642T-500	31	BT12	164	SDP404	12	23692	47
642TB	29	BT13	162/164	SDP404-100	12	23693	47
642TB-50	29	BT14	162/164	SDP404-5	12	23694	47
642TBC	29	BT15	164	SDP451	12	23695	47
642TC	31	BT16	164	SDP451-25	12	23696	47
644T	31	BT17	164	SDP451-3	12	23697	47
644TB	29	BT18	164	SDP451-5	12	23698	47
644TC	31	BT19	164	SDP452	12	23699	47
64520TB	29	BT20	162/164	SDP452-100	12	23700	47
64522TB	29	BT20E	165	SDP452-5	12	23701	47
64524TB	29	BT21	162/164	SDP454	7	23702	47
64526TB	29	BT21E	165	SDP454-10	7	23703	47
646T	31	BT22	163	SDP454-5	7	23704	47
646TC	31	BT22E	165	SDP455-5	7	23705	47
65-10	183	BT23	163	SDP501N	12	23706	47
6520TB	29	BT23E	165	SDP502	12	23707	47
6522TB	29	BT24	162/163	SDP502-25	12	23708	47
6524TB	29	BT25	163	SDP701-10	12	23709	47
6526TB	29	BT26	163	SDP701N	12	23710	47
66-100	183	BT27	162/163	SK450	42	23711	47
6620TB	30	BT28	163	SK475	42	23712	47
6622TB	30	BT29	164	SKA	42	23713	47
6624TB	30	BT31	164	W178	76/77	23714	47
6666T	33	BT32	164	W178S	33/77	23715	47
66H	183	BT32E	165	W179	76/77	23716	47
6720TB	30	BT33	162/164	W187	76/77		
6722TB	30	BT33E	165	W188	76/77		
6724TB	30	BT35	162/164	W196	76/77		
6726TB	30	BT36	162/164	W205	76/77		
70240C	40	BT37	164	W206	76/77		
70240Z	41	BT38	164	W216	76/77		
70240Z-3	41	BT40	162/163	W217	76/77		
70240ZC	41	BT40E	165	W218	76/77		
7036-10	16	BT41	163	W220	76/77		
70360C	40	BT41E	165	W225	76/77		
70360Z	41	BT42	164	W229	76/77		
70360Z-3	41	BT42E	165	W235	76/77		
7036H-10	16	BT43E	165	W236	76/77		
7046-10	16	BT45	164	W236S	33/77		
7046H-10	16	BT48	163				
70500Z	41	BT49	163				
70500Z-3	41	BT5	162				
7060-10	16	BT50	163				

2017 ADDITIONS



NEW PRODUCTS FROM SHARK

SW-MIG/STICK 140 KIT

Item# 17024

Features & Benefits:

- Dual groove drive roller
- Thermostatic heat protection
- Infinite wire speed control
- Inverter

Page 90



CERAMIC and POLY BACKED FLAP DISCS

Features & Benefits:

- Longest life grain
- For use on flat or curved surfaces
- Aggressive shape disc

Page 57

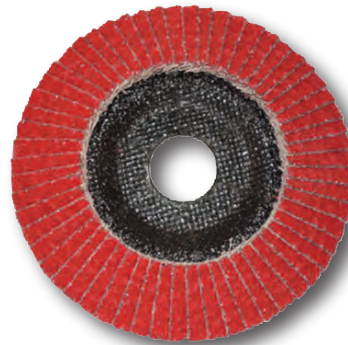

ZIRCONIA MINI BELTS FOR BELT SANDERS

Item# 13182-13189

Features & Benefits:

- Durable Poly/Cotton Backing
- Long Life Zirconia will outlast Aluminum Oxide
- Performs better on Aluminum than Aluminum Oxide
- A must for Ford F-150 work

Page 51



MIG SK180i WELDER

Item# 17023

Features & Benefits:

- Dual groove drive roller
- Thermostatic heat protection
- Infinite wire speed control

Page 88



NEW!

POWERED AIR PURIFYING RESPIRATOR

Item# 14250

Features & Benefits:

- 99.97% Filter Efficiency
- Variable Air Flow Rate
- Includes Auto-Darkening Lens

Page 96



WALNUT SHELL BLASTING MEDIA

Item# 13076

- For blasting intake valves to remove carbon build-up
- Use on Audi, BMW and Minis for manifold intake cleaning
- Safely removes carbon without damaging engine
- Made in USA

Page 188

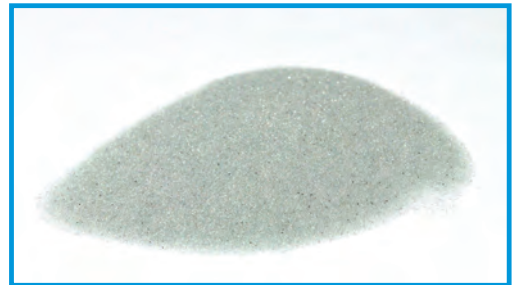

GLASS BEAD BLASTING MEDIA

Item# 13077 (Coarse) and 13078 (Medium)

- Removes:
 - Surface Rust
 - Debris and Corrosion
 - Paint in Auto Body Applications
 - Made in USA

Page 188

SHARK INDUSTRIES



6700 Bleck Drive • Rockford, MN 55373

763-565-1900 • Fax: 763-565-1901

800-537-4275

info@sharkind.com • orders@sharkind.com